

DESCRIPTION:
SNAPRACK, HANGER BOLT CLAMP

PART NUMBER(S):
242-01102

DRAWN BY:
 D.Ryan

REVISION:
A

SnapNrack™
 Solar Mounting Solutions

595 MARKET STREET, 29TH FLOOR • SAN FRANCISCO, CA 94105 USA
 PHONE (415) 580-6900 • FAX (415) 580-6902

THE INFORMATION IN THIS DRAWING IS CONFIDENTIAL AND PROPRIETARY. ANY REPRODUCTION, DISCLOSURE, OR USE THEREOF IS PROHIBITED WITHOUT THE WRITTEN CONSENT OF SUNRUN SOUTH LLC.

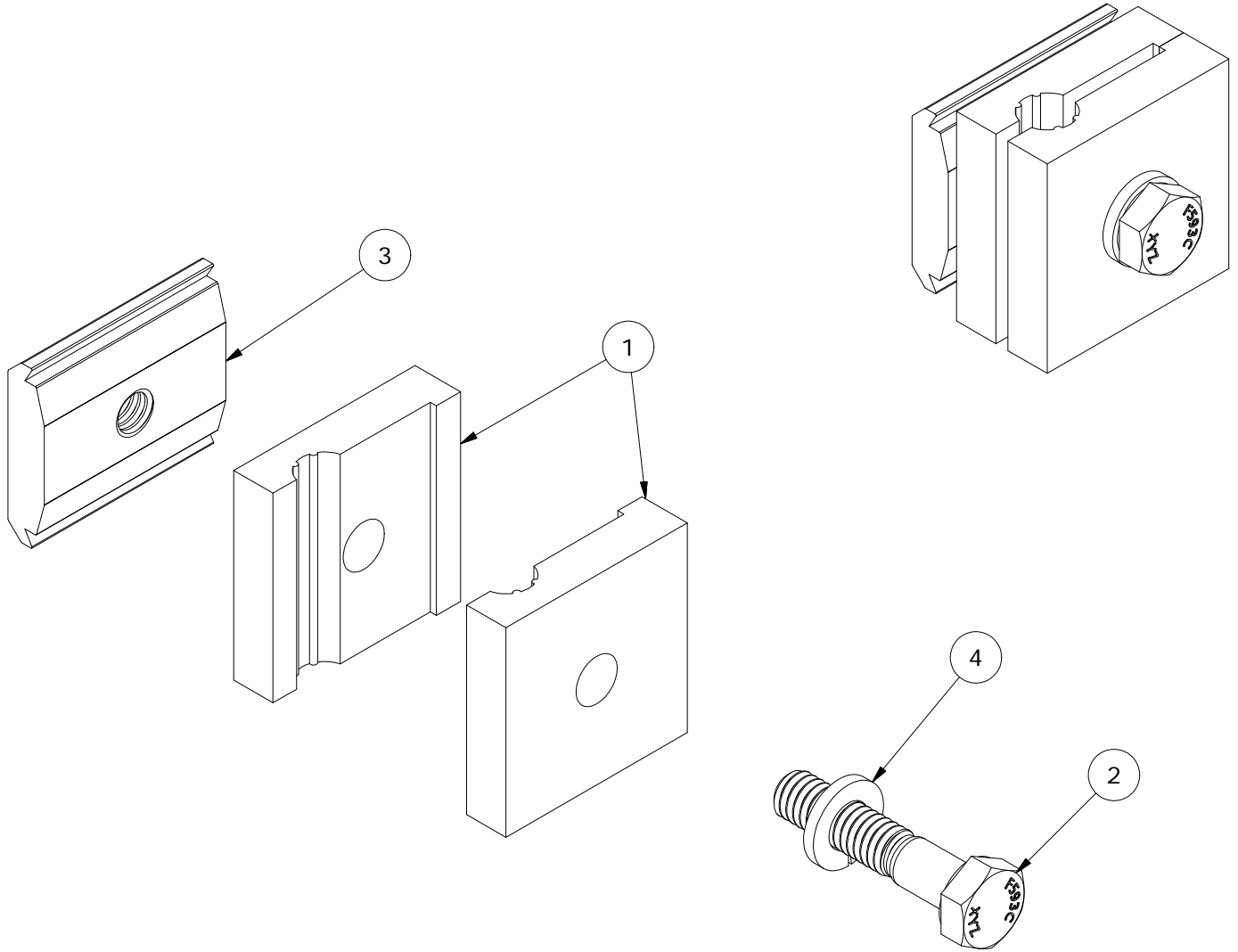

PARTS LIST		
ITEM	QTY	DESCRIPTION
1	2	SNAPNRACK HANGER BOLT CLAMP
2	1	5-16IN-18 X 1-1-2IN SS HCS BOLT
3	1	SNAPNRACK CHANNEL NUT 5/16IN-18
4	1	5/16IN SS SPLIT LOCK WASHER

MATERIALS:	6000 SERIES ALUMINUM, STAINLESS STEEL	OPTIONS:
DESIGN LOAD (LBS):	318 UP, 394 DOWN, 417 SIDE	
ULTIMATE LOAD (LBS):	1192 UP, 1152 DOWN, 1500 SIDE	
TORQUE SPECIFICATION:	10+ LB-FT	
CERTIFICATION:	UL 2703, FILE E359313	
WEIGHT (LBS):	0.22	

DESCRIPTION:

SNAPNRACK, HANGER BOLT CLAMP

DRAWN BY:

D.Ryan

SnapNrack™
Solar Mounting Solutions

PART NUMBER(S):

242-01102

REVISION:

A

595 MARKET STREET, 29TH FLOOR • SAN FRANCISCO, CA 94105 USA
PHONE (415) 580-6900 • FAX (415) 580-6902

THE INFORMATION IN THIS DRAWING IS CONFIDENTIAL AND PROPRIETARY. ANY REPRODUCTION, DISCLOSURE, OR USE THEREOF IS PROHIBITED WITHOUT THE WRITTEN CONSENT OF SUNRUN SOUTH LLC.

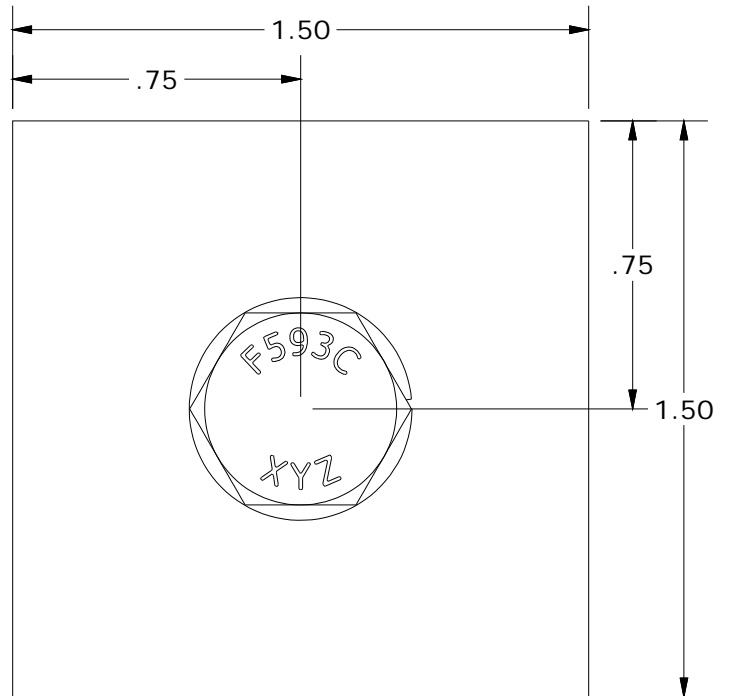
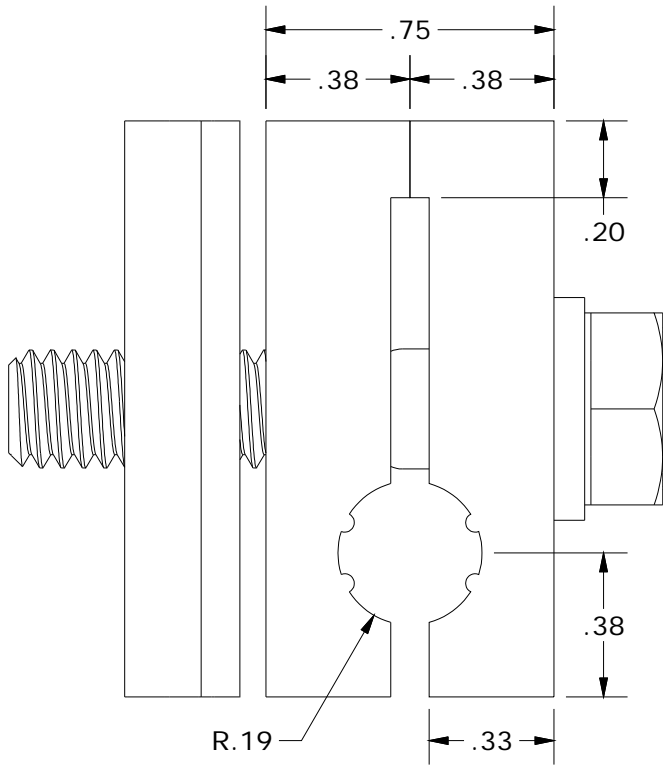

ALL DIMENSIONS IN INCHES