

DESCRIPTION:
SNAPNRACK, UNIVERSAL END CLAMP

PART NUMBER(S):
242-02215

DRAWN BY:
 D.Ryan

REVISION:
A

SnapNrack™
 Solar Mounting Solutions

595 MARKET STREET, 29TH FLOOR • SAN FRANCISCO, CA 94105 USA
 PHONE (415) 580-6900 • FAX (415) 580-6902

THE INFORMATION IN THIS DRAWING IS CONFIDENTIAL AND PROPRIETARY. ANY REPRODUCTION, DISCLOSURE, OR USE THEREOF IS PROHIBITED WITHOUT THE WRITTEN CONSENT OF SUNRUN SOUTH LLC.

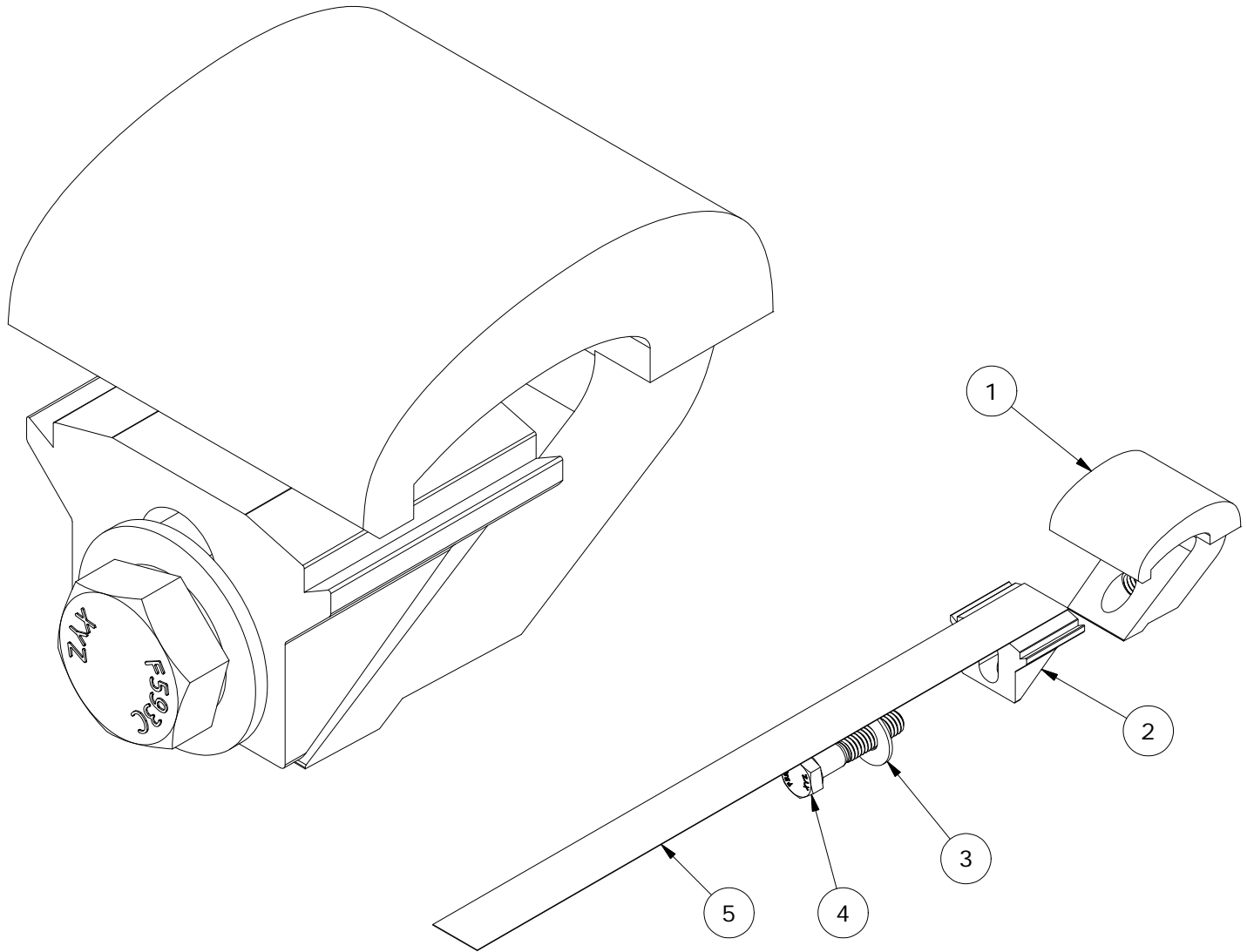

PARTS LIST		
ITEM	QTY	DESCRIPTION
1	1	SNAPNRACK END CLAMP UNIVERSAL WAVE
2	1	SNAPNRACK, UNIVERSAL END CLAMP WEDGE
3	1	5/16IN X 3/4IN SS FLAT WASHER
4	1	BOLT, HEX CAP, 5/16IN-18 X 1-1/2IN, SS
5	1	SNAPNRACK UEC PULL STRAP

MATERIALS:	6000 SERIES ALUMINUM, STAINLESS STEEL	OPTIONS:
DESIGN LOAD (LBS):	800	
ULTIMATE LOAD (LBS):	2400	
TORQUE SPECIFICATION:	10+ LB-FT	
CERTIFICATION:	UL 2703, FILE E359313	
WEIGHT (LBS):	0.24	

DESCRIPTION:

SNAPRACK, UNIVERSAL END CLAMP

DRAWN BY:

D.Ryan



PART NUMBER(S):

242-02215

REVISION:

A

595 MARKET STREET, 29TH FLOOR • SAN FRANCISCO, CA 94105 USA
PHONE (415) 580-6900 • FAX (415) 580-6902

THE INFORMATION IN THIS DRAWING IS CONFIDENTIAL AND PROPRIETARY. ANY REPRODUCTION, DISCLOSURE, OR USE THEREOF IS PROHIBITED WITHOUT THE WRITTEN CONSENT OF SUNRUN SOUTH LLC.

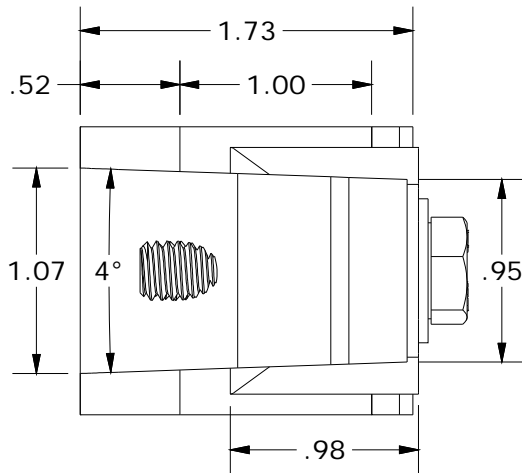
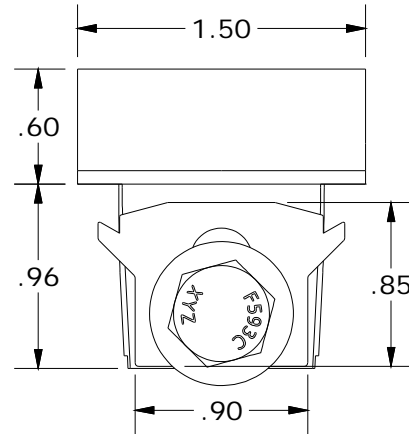
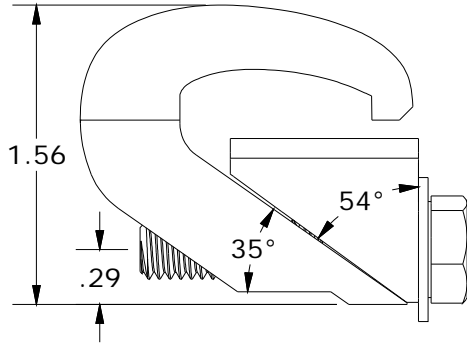

ALL DIMENSIONS IN INCHES