

DESCRIPTION:
**SNAPNRACK, TDS, ULTRA RAIL VARIABLE TILT
 HARDWARE KIT**

DOC NUMBER:
 SNR-DC-01362

SnapNrack®

PART NUMBER(S):

242-92116

DRAWN BY:
 H.WULFEKOETTER

REV: **C** DATE:
 1/23/2023

SUNRUN INSTALLATION SERVICES INC.
 225 BUSH STREET, SUITE 1400 • SAN FRANCISCO, CA 94104 USA
 PHONE (877) 732-2860 • CONTACT@SNAPNRACK.COM
THE INFORMATION IN THIS DRAWING IS CONFIDENTIAL AND PROPRIETARY. ANY REPRODUCTION, DISCLOSURE, OR USE THEREOF IS PROHIBITED WITHOUT THE WRITTEN CONSENT OF SUNRUN SOUTH LLC.

UNITS: IN, LB, DEG [MM, KG, DEG]

SHEET: 1:1

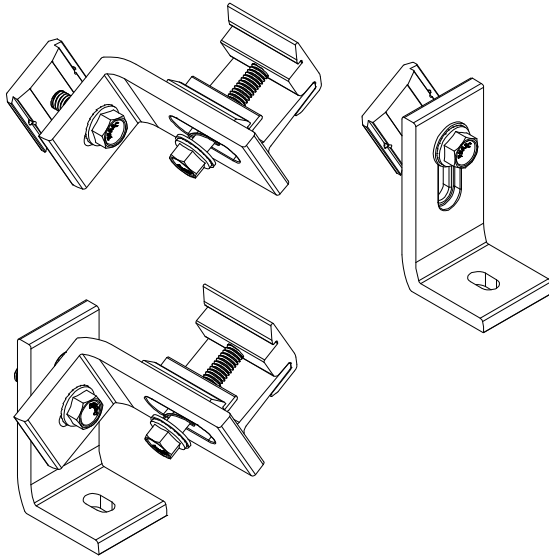

ISO
 SCALE 1:3

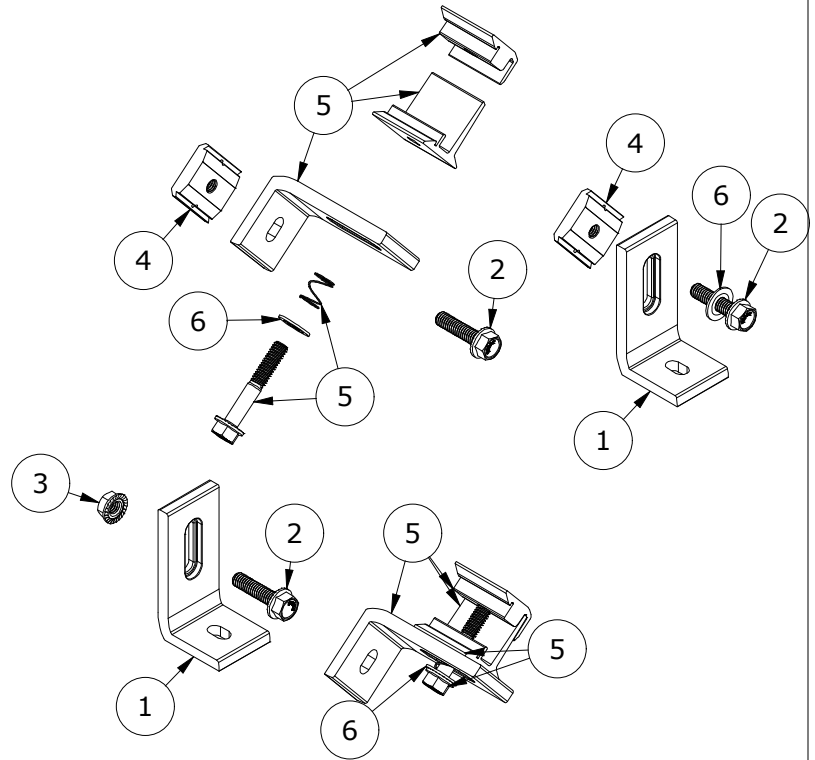

EXPLODED
 SCALE 1:4

PARTS LIST

ITEM	QTY	DESCRIPTION
1	2	SNAPNRACK, AP90 L FOOT, STEPPED, CLEAR
2	3	BOLT, FLANGED HEX, 5/16IN-18 X 1-1/4IN, SS
3	1	NUT, FLANGE, SERRATED, 5/16IN-18, SS
4	2	SNAPNRACK, BONDING CHANNEL NUT
5	2	SNAPNRACK, ULTRA RAIL ALL PURPOSE L FOOT (90 DEG), SILVER
6	1	5-16IN X 3-4IN SS FLAT WASHER

MATERIALS: 6000 SERIES ALUMINUM, STAINLESS STEEL

DESIGN LOAD (LBS): SEE ENGINEERING REPORT

ULTIMATE LOAD (LBS): SEE ENGINEERING REPORT

TORQUE SPECIFICATION: 12 FT-LBS

CERTIFICATION: UL 2703, FILE E359313

WEIGHT (LBS): 1.31