

**SNAPNRACK CORRUGATED STRADDLE BLOCK WITH SNAPNRACK ULTRA RAIL ALL PURPOSE L-FOOT (90°) FOR MOUNTING ON CORRUGATED ROOFS**

REFER TO SNAPNRACK ENGINEERING CHARTS FOR APPLICABLE RAIL SPANS. "BIN" NUMBER ON CHART SHOULD MATCH "BIN" NUMBER ON THIS DRAWING

MIN. 3 FULL THREADS PROJECTING THROUGH PURLIN WHEN FASTENING WITH 1/4"Ø TEK SCREW OR EQUIVALENT. USE TEK SCREW MANUFACTURER TORQUE SPECIFICATION

UTILIZE A 5/16"Ø S.S. LAG SCREW INTO WOODEN RAFTERS WITH A MINIMUM PENETRATION DEPTH OF 2 1/2" INTO THE RAFTER.

REFER TO SNAPNRACK INSTALLATION MANUAL FOR 5/16"Ø HARDWARE TORQUE SPECIFICATIONS

RAIL CAN BE MOUNTED ON EITHER SIDE OF THE L-FOOT

FOR LEVELING DETAILS, REFER TO SNAPNRACK DETAIL DRAWING "SNR-DC-00332 ULTRA RAIL, COMPONENT DETAIL, LEVELING EXTENSION KIT"

BIN:  
**5**

REVISION:			
1	5/7/2019	NEW DETAIL	MJA
1	6/18/2019	DRO-00138	MJA

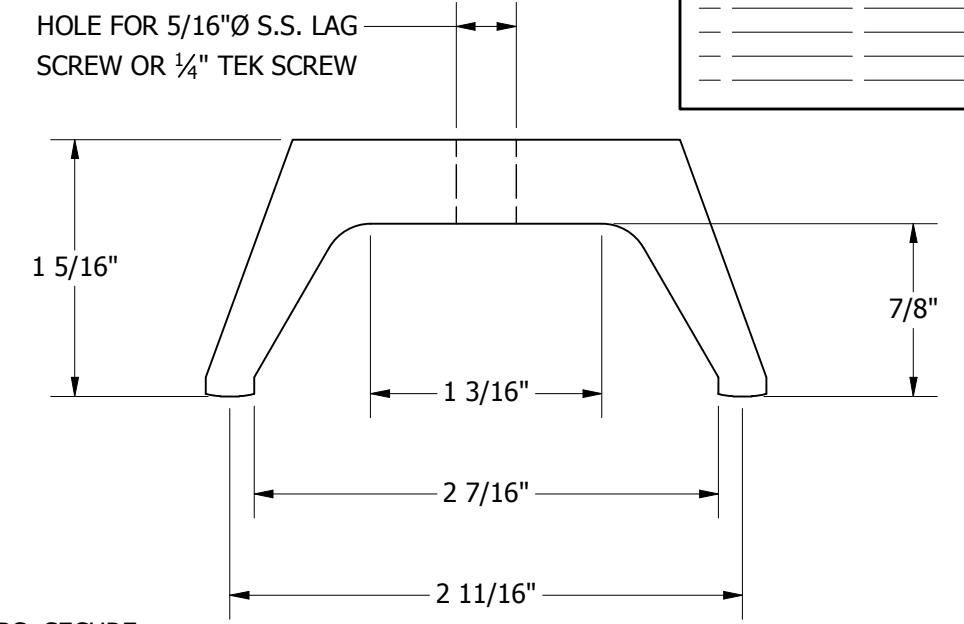
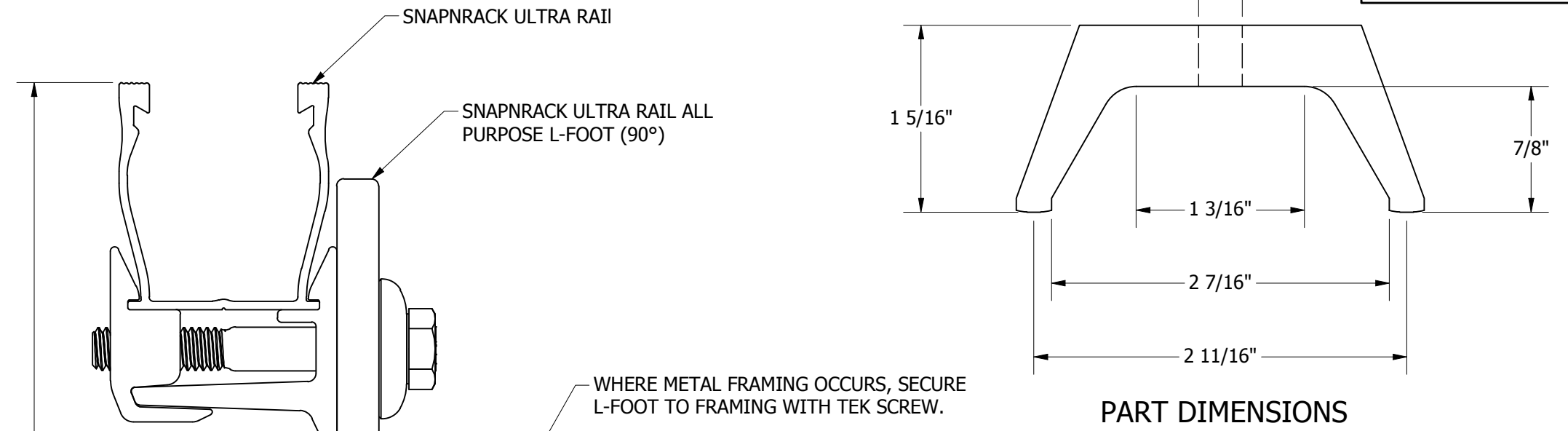

**MODULE HEIGHT OFF ROOF, RANGE:**  
UR-40: 4 5/8" - 5 5/8"  
UR-60: 5 1/4" - 6 1/4"

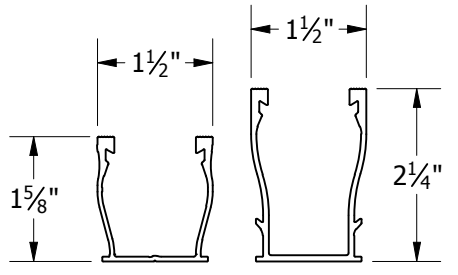
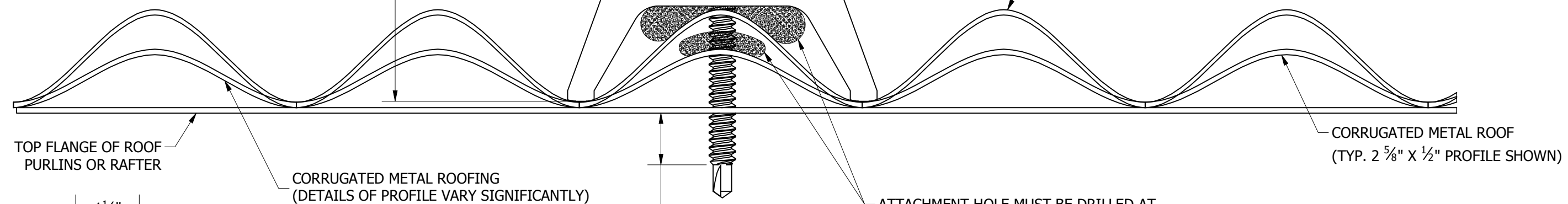

MIN. 3 FULL THREADS PROJECTING THROUGH MEMBER IF FASTENING INTO STEEL ROLL FORMS. 2 1/2" MIN. LAG EMBEDMENT IF FASTENING INTO WOODEN RAFTERS.

**UR-40 RAIL | UR-60 RAIL**  
FOR USE WITH SNAPNRACK ULTRA SERIES RAILS

	Sunrun South LLC 595 MARKET STREET, 29TH FLOOR • SAN FRANCISCO, CA 94105 USA PHONE (415) 580-6900 • FAX (415) 580-6902 <small>THE INFORMATION IN THIS DRAWING IS CONFIDENTIAL AND PROPRIETARY. ANY REPRODUCTION, DISCLOSURE, OR USE THEREOF IS PROHIBITED WITHOUT THE WRITTEN CONSENT OF SUNRUN SOUTH LLC.</small>	DESIGNER: <u>G.MCPHEETERS</u>	SCALE: <u>DNS</u>	DRAWING NUMBER: <u>SNR-DC-00343</u>	DESCRIPTION: <b>ULTRA RAIL, ATTACHMENT DETAIL, CORRUGATED STRADDLE BLOCK</b>	REV: <b>1</b>
		DRAFTER: <u>M.AFFENTRANGER</u>	DATE: <u>6/18/2019</u>	APPROVED BY: <u>B.PETERSON</u>		