

SNAPNRACK ULTRA RAIL TILE ROOF HOOK WS FOR MOUNTING TO W AND S PROFILE TILE ROOFS

REFER TO SNAPNRACK ENGINEERING CHARTS FOR APPLICABLE RAIL SPANS. "BIN" NUMBER ON CHART SHOULD MATCH "BIN" NUMBER ON THIS DRAWING

5/16"Ø S.S. LAG SCREWS MUST EMBED A MIN. OF 2 1/2" INTO STRUCTURAL MEMBER

REFER TO SNAPNRACK INSTALLATION MANUAL FOR 5/16"Ø HARDWARE TORQUE SPECIFICATIONS

RAILS CAN MOUNT TO EITHER SIDE OF TILE HOOK (UPSLOPE VS. DOWNSLOPE)

RAILS CAN BE LEVELED UP TO 1 1/4" USING THE SLOT IN THE TILE HOOK

BIN: 7

REVISION:			
1	5/7/2019	NEW DETAIL	MJA

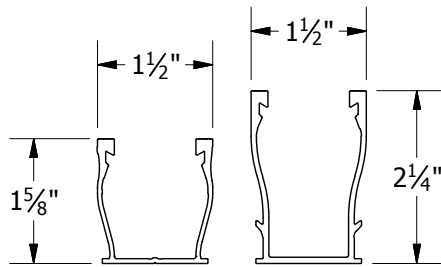
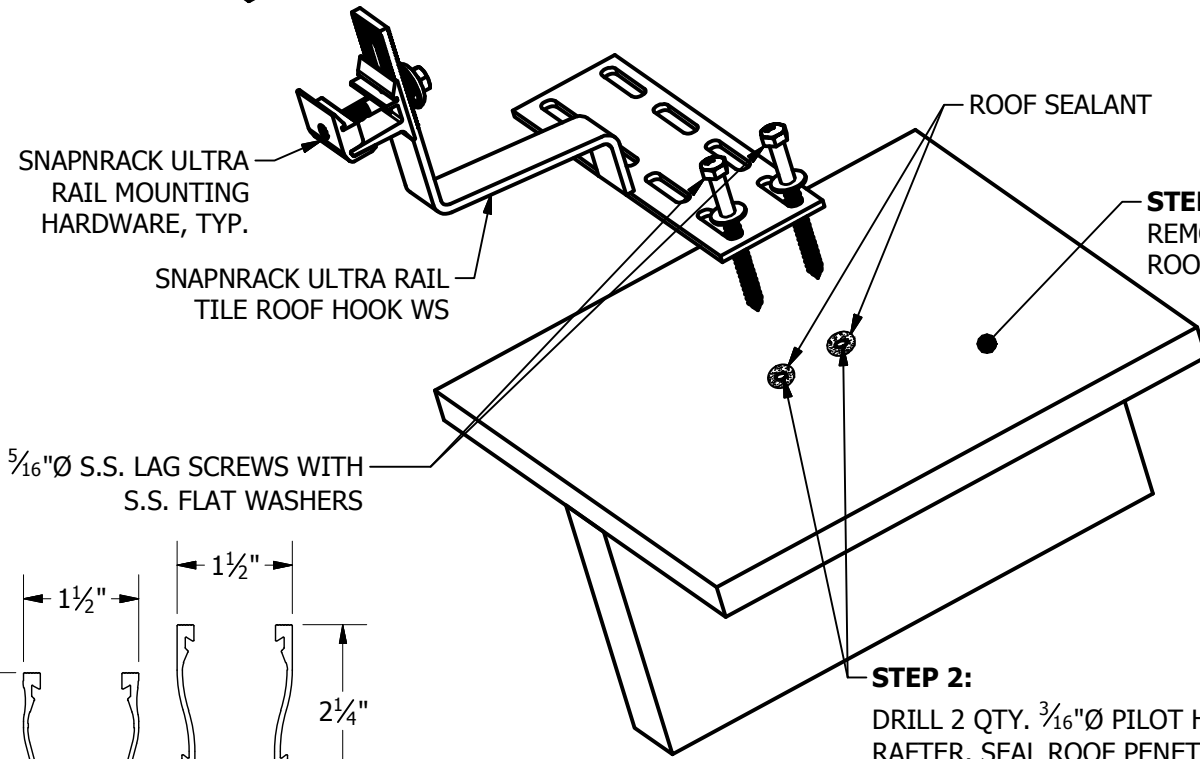
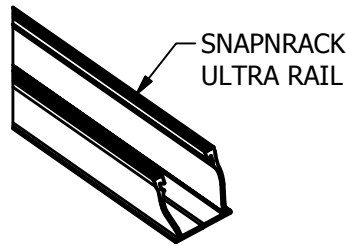
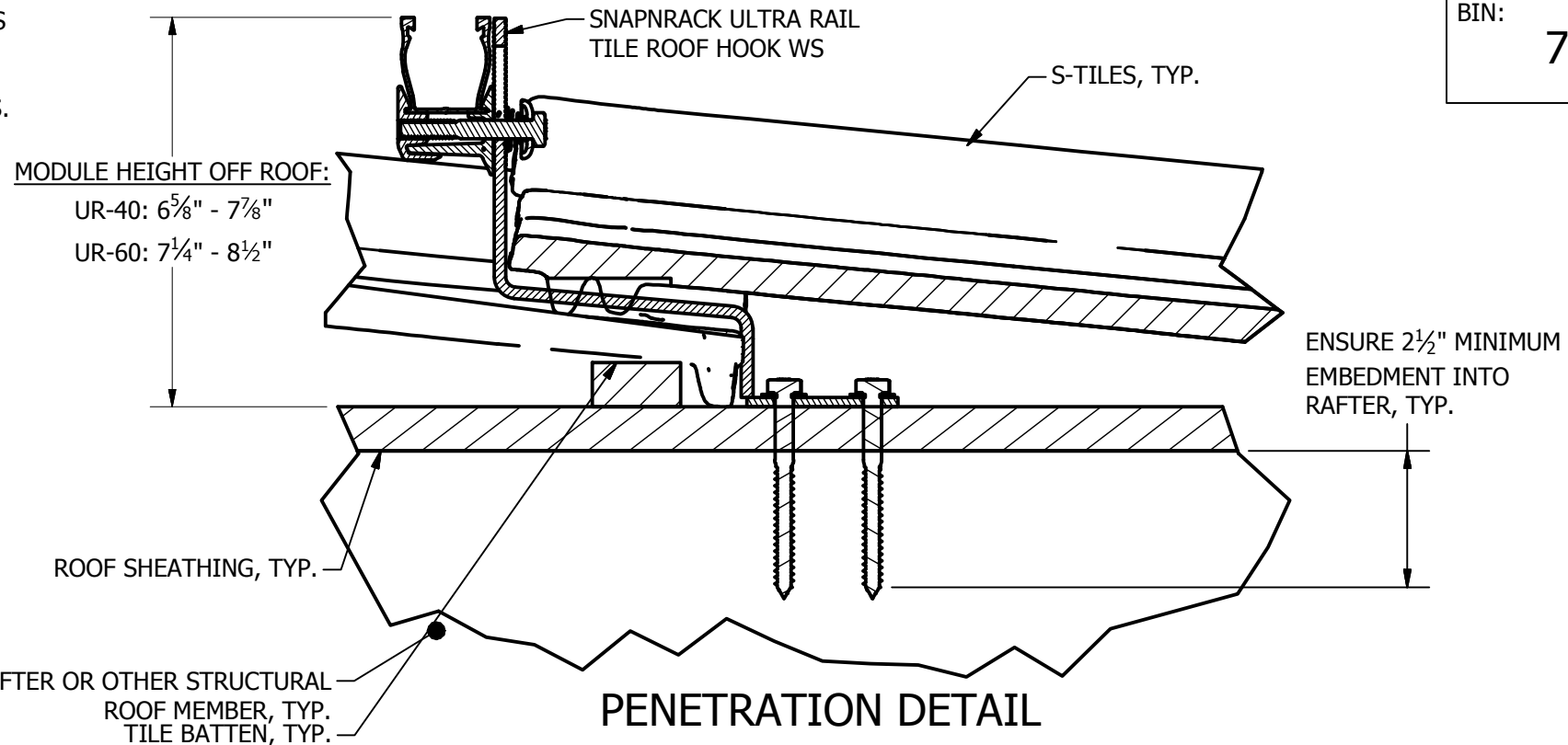

UR-40 RAIL | UR-60 RAIL
FOR USE WITH SNAPNRACK ULTRA SERIES RAILS

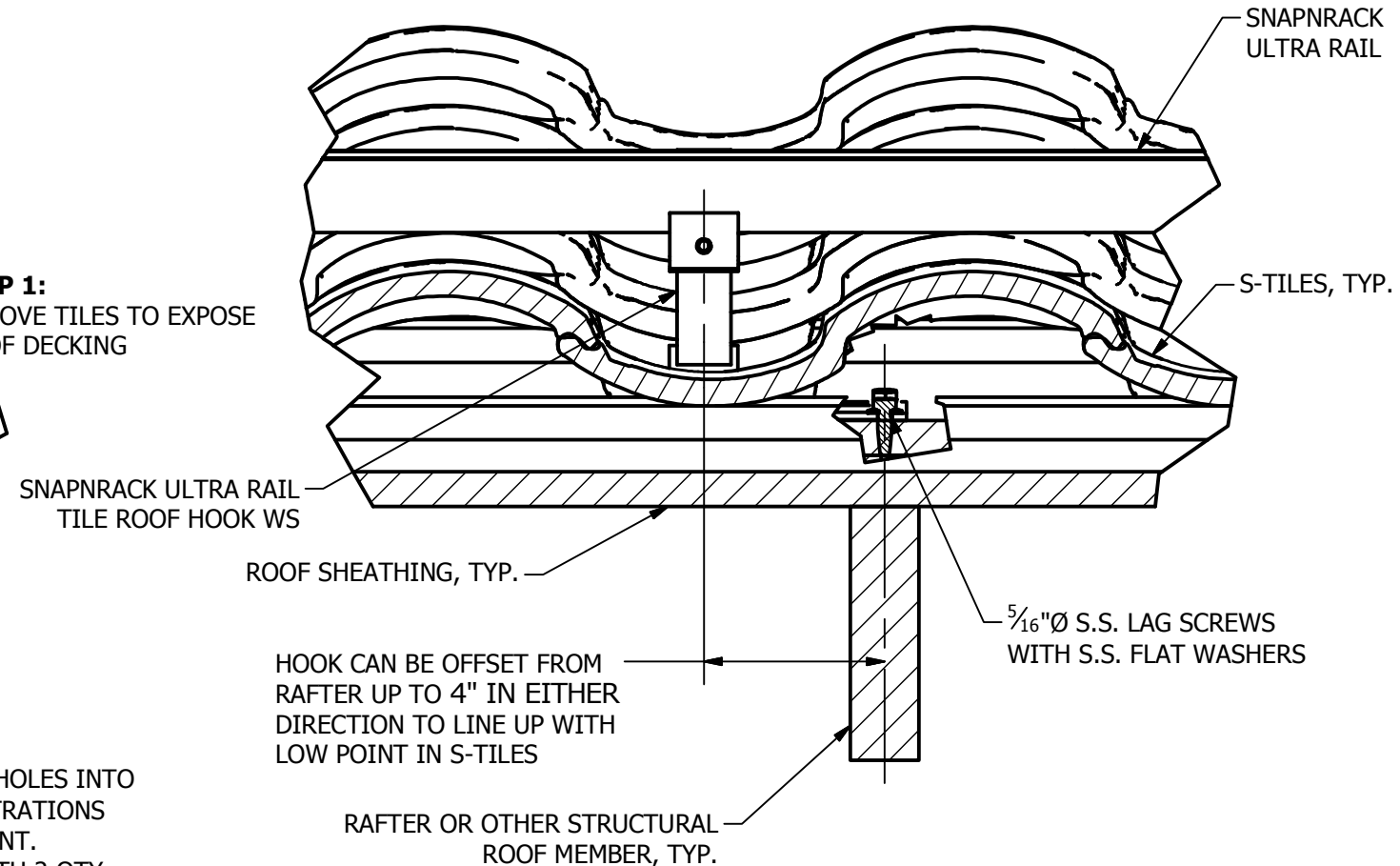

	Sunrun South LLC 595 MARKET STREET, 29TH FLOOR • SAN FRANCISCO, CA 94105 USA PHONE (415) 580-6900 • FAX (415) 580-6902 <small>THE INFORMATION IN THIS DRAWING IS CONFIDENTIAL AND PROPRIETARY. ANY REPRODUCTION, DISCLOSURE, OR USE THEREOF IS PROHIBITED WITHOUT THE WRITTEN CONSENT OF SUNRUN SOUTH LLC.</small>	DESIGNER: <u>D.RYAN</u>	SCALE: <u>DNS</u>	DRAWING NUMBER: <u>SNR-DC-00355</u>	DESCRIPTION: <u>ULTRA RAIL, ATTACHMENT DETAIL, ULTRA RAIL TILE ROOF HOOK WS TO RAFTER</u>	REV: <u>1</u>
		DRAFTER: <u>M.AFFENTRANGER</u>	DATE: <u>5/7/2019</u>	APPROVED BY: <u>B.PETERSON</u>		