

SnapNrack™

Solar Mounting Solutions

Ultra Rail

Residential Roof Mount System
Installation Manual

snapnrack.com



2703 Listed — PV Mounting System

SnapNrack Ultra Rail Solar Mounting System offers a low profile, visually appealing, photovoltaic (PV) module installation system. This innovative system simplifies the process of installing solar PV modules, shortens installation times, and lowers installation costs..

SnapNrack systems, when installed in accordance with this manual, will be structurally adequate for the specific installation site and will meet the local and International Building Code. Systems will also be bonded to ground, under SnapNrack's UL 2703 Listing.

The SnapNrack installation system is a set of engineered components that can be assembled into a wide variety of solar mounting structures. It is designed to be installed by qualified solar installation technicians. With SnapNrack you will be able to solve virtually any PV module mounting challenge.

Benefits of Installing the SnapNrack Ultra Rail System

Install With Existing Roof Attachments

Compatible with existing SnapNrack roof attachments

Install With Very Few Tools

All Ultra Rail hardware is attached using a standard 1/2" socket

Built in Wire Management and Aesthetics

Extensive wire management solutions have been designed specifically for the system that adapts to multiple possible mounting positions.

The system is designed to be aesthetically pleasing on its own, so it does not require an aesthetic skirt. SnapNrack does offer an optional skirt for those looking for a high end look to the system.

Step 1: Project Plans

Certification Details4
Component Details5
Pre-Installation Requirements9

Step 2: Roof Attachment

L Foot Mount13
SpeedSeal™ Foot.15
SpeedSeal™ DeckFoot.17
Tile Roof Hook F19
Tile Roof Hook WS21
Metal Roof Base23
Corrugated Straddle Block.25
Seam Clamp27
Ultra Rail Mounting Hardware29
Fixed Tilt Mounts31

Step 3: Rail Inspection

Installing and Leveling Rails34
Leveling Components36
UR-40 Rail Splice37
UR-60 Rail Splice38

Step 4: Module Installation

Module Installation39
Rail Finishing46

Step 5: Selecting Racking Accessories

Wire Management48
Module Level Power Electronics (MLPE) Installation.51

Grounding Specifications55

List of Approved Modules.62
List of Approved MLPE Devices.68

Mechanical Loading Specifications69

Certification Details

SnapNrack Ultra Rail system has been evaluated by Underwriters Laboratories (UL) and Listed to UL/ANSI Standard 2703 for Grounding/Bonding, Mechanical Loading, and Fire Classification.

Grounding/Bonding

The Ultra Rail system has been designed in compliance with UL Standard 2703 Section 9.1 Exception, which permits accessible components that **are not part** of the fault current ground path to **not be electrically bonded** to the mounting system (e.g. roof attachments, array skirt, etc.). For more details on the integrated grounding functionality see the [Grounding Specifications](#) section.

This racking system may be used to ground and/or mount a PV module complying with UL 1703 only when the specific module has been evaluated for grounding and/or mounting in compliance with the included instructions. See the [Grounding Specifications](#) for the list of modules tested with the Ultra Rail system for integrated grounding.

Ground Lugs have been evaluated to both UL 467 and UL 2703 Listing requirements.

Ultra Rail has been listed with a number of Module Level Power Electronic (MLPE) devices. A complete list can be found in the [Grounding Specifications](#) section.

The mounting system Bonding Listing is only valid when installed with a Non-Separately Derived PV system. The PV system is required to have a direct electrical connection to another source, such as connecting to the grid via a grid interactive inverter.

SnapNrack recommends that bare copper never come into contact with aluminum.

Mechanical Loading

The Ultra Rail system is Listed for mechanical loading for different load ratings depending on the mounting configuration and PV module installed. For more details on the mechanical loading details see the [Mechanical Loading Specifications](#) section.

SnapNrack engineered systems should only be used with SnapNrack components and hardware. Any application outside of those specified in this Installation Manual and the Structural Engineering Report may void the warranty and structural certification could become invalid.

If the module clamps have been engaged and need to be loosened and reengaged, SnapNrack recommends moving the module frame 3mm to engage the bonding pin in a new location.

The UL Listing covers mechanical load ratings for the various span lengths, module orientations and positive, negative, and side load ratings. These values can be found in the [Mechanical Loading Specifications](#) section.

SnapNrack recommends a periodic re-inspection of the completed installation for loose components, loose fasteners, and any corrosion, such that if found, the affected components are to be immediately replaced.

Fire

The Ultra Rail system has been evaluated for a Class A System Fire Classification for a Steep-Sloped Roof ($\geq 2:12$ pitch) using Type 1 and Type 2 modules. In order to maintain the System Classification, modules are clamped to the mounting rails between 0 and 12 inches from the top and bottom edges of the module.

The Ultra Rail system has been evaluated for a Class A System Fire Classification for a Low-Sloped Roof ($< 2:12$ pitch) using Type 1 and Type 2 modules. In order to maintain the System Classification, modules are clamped to the mounting rails between 0 and 16.3 inches from the top and bottom edges of the module.

The optional Array Skirt accessory has also been evaluated and the Ultra Rail system will maintain the Class A System Fire Classification detailed above if installed with the Skirt.

Because the system was tested at 5 inches above the test roof fixture Ultra Rail can be installed without any height restrictions and will maintain the Class A System Fire Classification. See [Rail Installation](#) section for potential module-specific height restrictions due to module temperature.

Structural Components

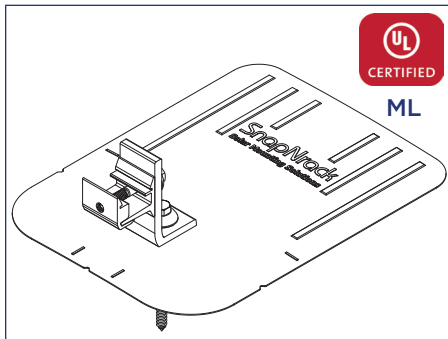

ML

Composition Roof Attachment
Roof attachment kit for composition shingle roofs including L foot, umbrella lag screw, flashing, and hardware

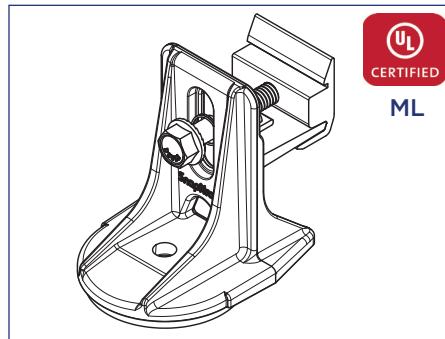

ML

Composition Roof Attachment
Roof attachment kit for composition shingle roofs including chemically flashed L foot, lag screw, and hardware

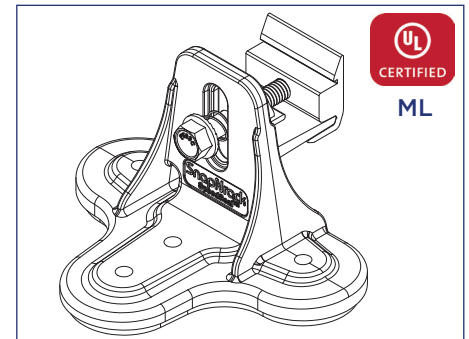

ML

Composition Roof Attachment
Roof attachment kit for composition shingle roofs including chemically flashed L foot, self-drilling deck screws, and hardware

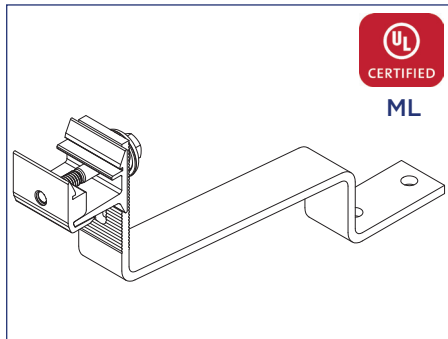

ML

Flat Tile Roof Attachment
Roof attachment kit for flat tile roofs including tile hook and hardware

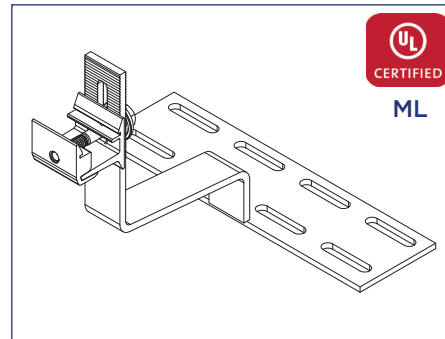

ML

W & S Tile Roof Attachment
Roof attachment kit for W and S tile roofs including tile hook and hardware

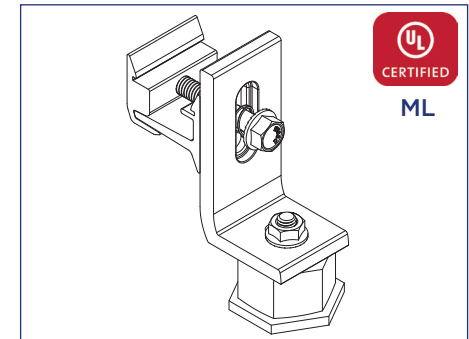

ML

Metal Roof Base Attachment
Roof attachment kit for flat metal roofs including metal roof base, L foot, and hardware

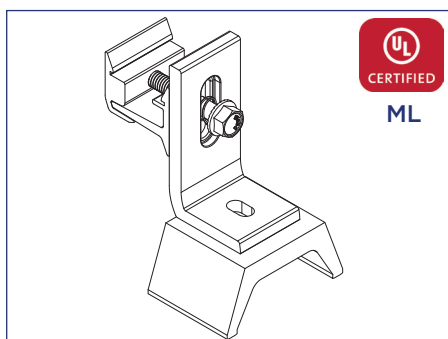

ML

Corrugated Roof Block Attachment
Roof attachment for sinusoidal corrugated metal roofs including roof block, L foot, and hardware

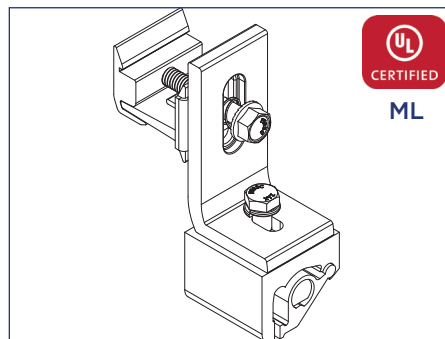

ML

Seam Clamp Roof Attachment
Roof attachment for standing seam metal roofs including seam clamp, L foot, and hardware

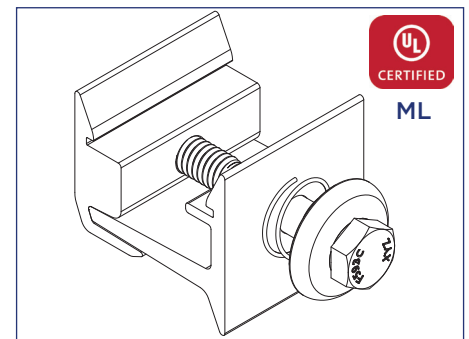

ML

Ultra Rail Mounting Hardware
Hardware kit for attaching Ultra Rail to any roof attachment that uses an L foot or other slotted mount that accepts 5/16" hardware

UL Listing Legend:

ML - Evaluated for Mechanical Loading

G/B - Evaluated for Grounding/Bonding

Structural Components

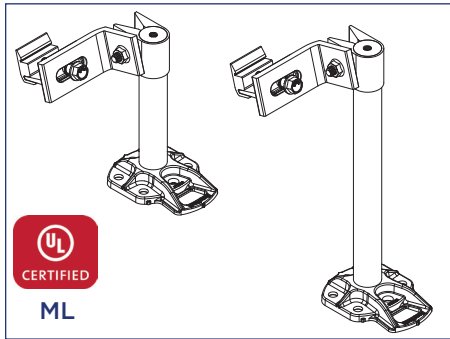

OmniBase™ with Fixed Tilt Standoff Roof Attachments

Roof attachment kits providing additional tilt off roof surface including standoffs, bases, and hardware

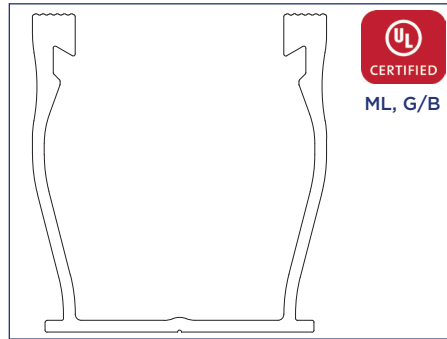

UR-40 Rail

UR-40 rail for Ultra Rail roof mount racking system

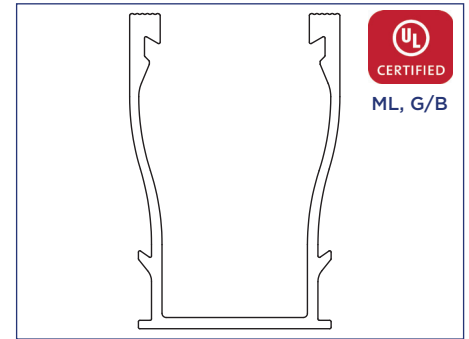

UR-60 Rail

UR-60 rail for Ultra Rail roof mount racking system

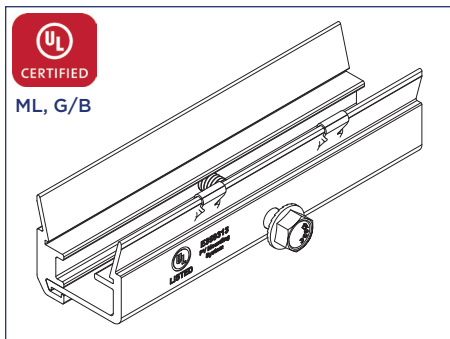

UR-40 Rail Splice

UR-40 rail splice component including two splice halves and hardware



UR-60 Rail Splice

UR-60 rail splice component including slide-on sleeve and hardware

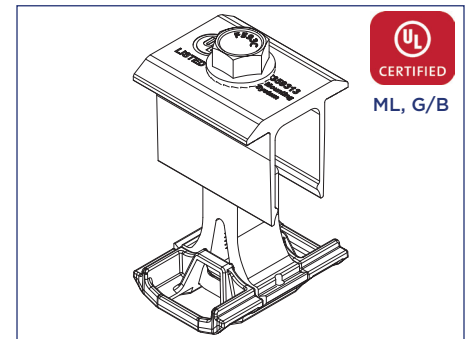

Ultra Rail Mid Clamp

Universal top-down module mid clamp including clamp and hardware

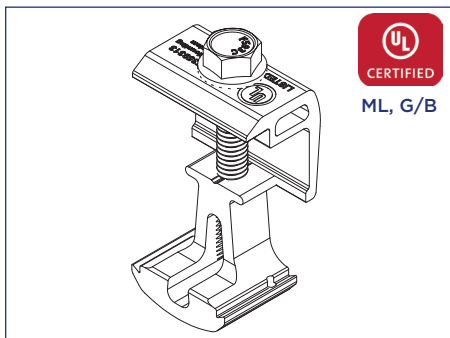

Ultra Rail End Clamp

Universal top-down module end clamp including clamp and hardware

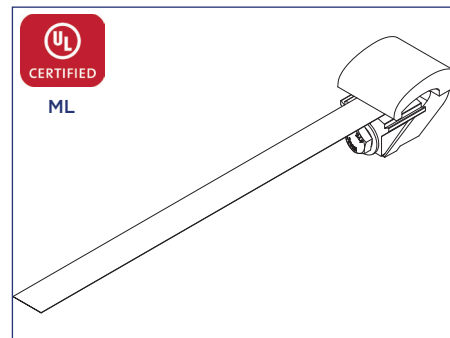

Universal End Clamp

Bottom-mount module end clamp including clamp and hardware

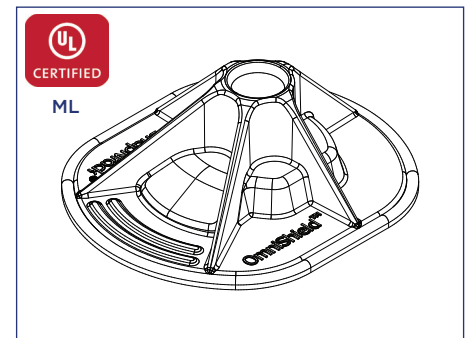

OmniShield

Roof Flashing & support for OmniBase™ Standoffs & Tilt Standoffs

UL Listing Legend:

- ML - Evaluated for Mechanical Loading
- G/B - Evaluated for Grounding/Bonding

Wire Management/Grounding Component

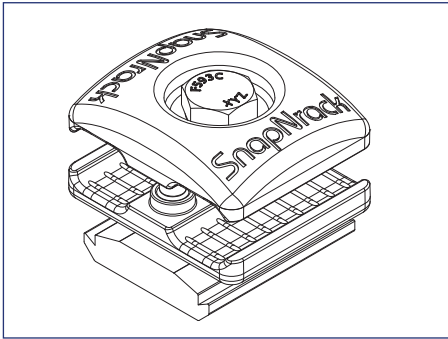

Universal Wire Clamp

Wire management component used to secure conductors between rails

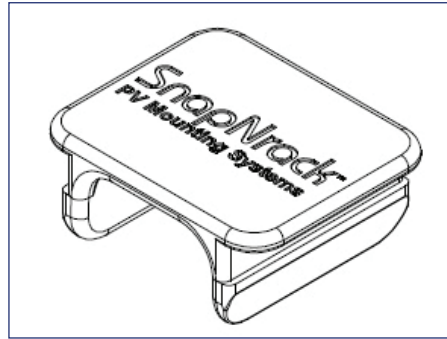

Wire Retention Clip

Wire management component used to secure conductors in rails

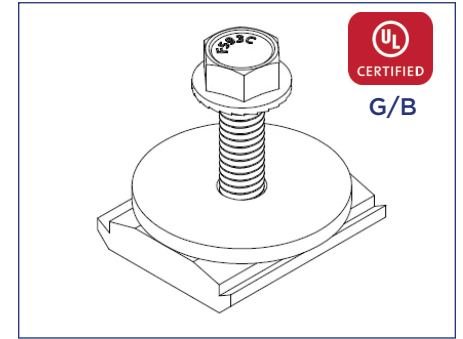

MLPE Rail Attachment Kit

Rail attachment for module level power electronics like microinverters and optimizers

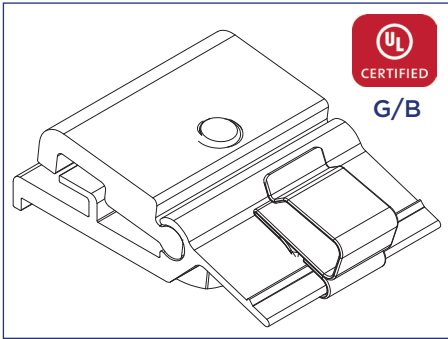

MLPE Frame Attachment Kit

Module frame attachment for module level power electronics like microinverters and optimizers

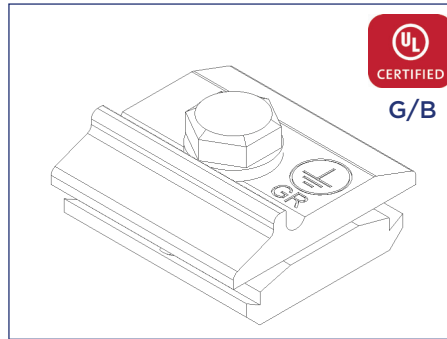

SnapNrack Ground Lug

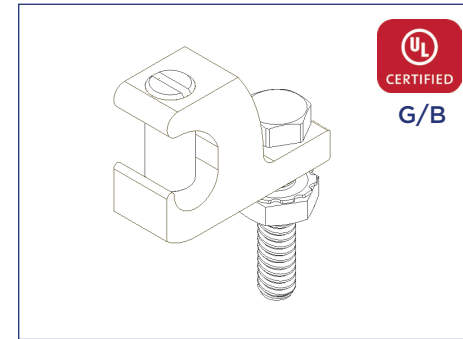

IlSCO Lay-In Lug - GBL-4DBT

Aesthetic Components



UR-40 Rail End Cap

Plastic end cap for UR-40 Rail

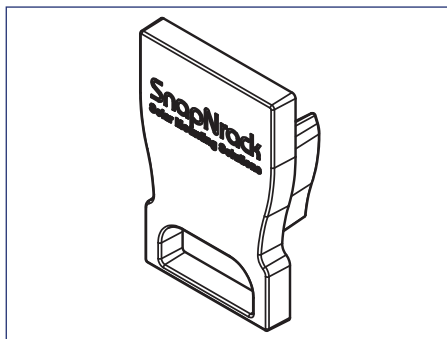

UR-60 Rail End Cap

Plastic end cap for UR-60 Rail

UL Listing Legend:

ML - Evaluated for Mechanical Loading
G/B - Evaluated for Grounding/Bonding

Hardware Torque Specifications

Hardware Description	Torque Specification
SnapNrack Ground Lug model 242-02101 to Grounding Electrode Conductor (6-12 AWG Solid Copper)	16 ft-lbs (192 in-lbs)
SnapNrack Ground Lug model 242-92202 to Grounding Electrode Conductor and Module Frame	8 ft-lbs (96 in-lbs)
Ilsco Lay-in Lug GBL-4DBT to Rail or Module Frame	2.92 ft-lbs (35 in-lbs)
Ilsco Lay-in Lug GBL-4DBT to Grounding Electrode Conductor (10-14 AWG Solid Copper)	1.67 ft-lbs (20 in-lbs)
Ilsco Lay-in Lug GBL-4DBT to Grounding Electrode Conductor (8 AWG Stranded Copper)	1.04 ft-lbs (25 in-lbs)
Ilsco Lay-in Lug GBL-4DBT to Grounding Electrode Conductor (4-6 AWG Stranded Copper); Ground Lug SGB-4 to Grounding Electrode Conductor (4-14 AWG Solid or Stranded Copper)	1.46 ft-lbs (35 in-lbs)
Ilsco Ground Lug SGB-4 to Module Frame	6.25 ft-lbs (75 in-lbs)
Adjustable End Clamp, Mid Clamp, Universal End Clamp, Flange Nut for MRB	10 ft-lbs (120 in-lbs)
Rail Splice, Flashed L Foot to Rail, Tile Hook F to Rail, Tile Hook WS to Rail, MRB to Rail, Seam Clamp to Rail	12 ft-lbs (144 in-lbs)
Ultra Rail End Clamp, Ultra Rail Mid Clamp	16 ft-lbs (192 in-lbs)
Standard Base Seam Clamp, Wide Base Seam Clamp	15-16 ft-lbs (180-192 in-lbs)
SolarEdge Frame Mounted Bracket to Module Frame	7 ft-lbs (84 in-lbs)
MLPE Rail Attachment Kit, MLPE Frame Attachment Kit	10 ft-lbs (120 in-lbs)
Enphase Frame Mounted Bracket to Module Frame	13 ft-lbs (156 in-lbs)

Site Survey

- Measure the roof surfaces and develop an accurate drawing, including any obstacles such as chimneys and roof vents.
- If plans are available, check to make sure that the plans match the final structure.
- Identify any roof access areas or keep-out areas as required by the local AHJ (i.e. fire lanes).
- Identify any construction issues that may complicate the process of locating roof framing members from the roof surface.
- If you find structural problems such as termite damage or cracked roof framing members that may compromise the structure's integrity, consult a structural engineer.

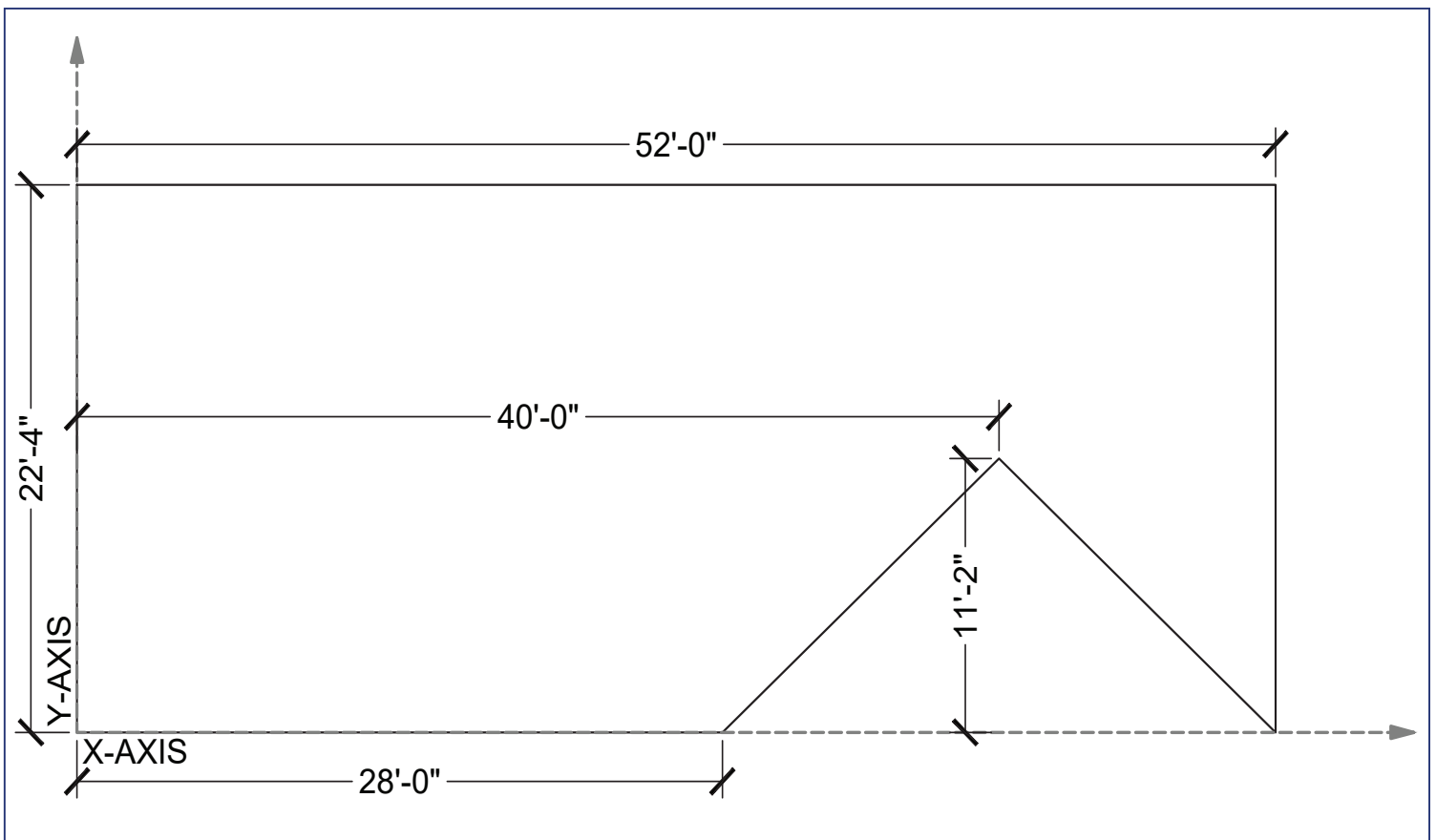

Design Guidance

- 1) Layout the modules in the available roof area. Adjacent modules in the same row are spaced 1/2" apart by Mid Clamps or 3/4" apart by Ultra Rail Mid Clamps. Adjustable End Clamps require an additional 1" of rail extending past module frame, while Universal End Clamps require no extra rail. When installing multiple rows of modules, a minimum spacing gap of 1/8" should be used between rows (3/4" is recommended for improved rail spans).
- 2) Draw the roof framing member location on the layout to identify where roof attachments can be installed.
- 3) Determine site conditions for calculating the engineering values, confirm site conditions and code versions comply with local AHJ requirements.
- 4) Reference site conditions and system specifications in Ultra Rail Structural Engineering Report to determine maximum attachment spacing and resulting cantilever values (34% of maximum attachment spacing).
- 5) Draw roof attachment locations on layout based on maximum attachment spacing and cantilever values.
- 6) Confirm design complies with UL 2703 Listing for Mechanical Loading. For more details on the mechanical loading details see the [Mechanical Loading Specifications](#) section.
- 7) To simplify the design process and automatically generate a bill of materials (BOM) for the mounting system, use the Ultra Rail Configuration Tool located on the SnapNrack website. Always refer to Approved Module Lists in Installation Manuals to ensure installation complies with UL 2703 Listing.
- 8) Mark distance from array edge to identifiable roof features in x and y axes.
- 9) Insert SnapNrack installation details in to design set specific to the project requirements.

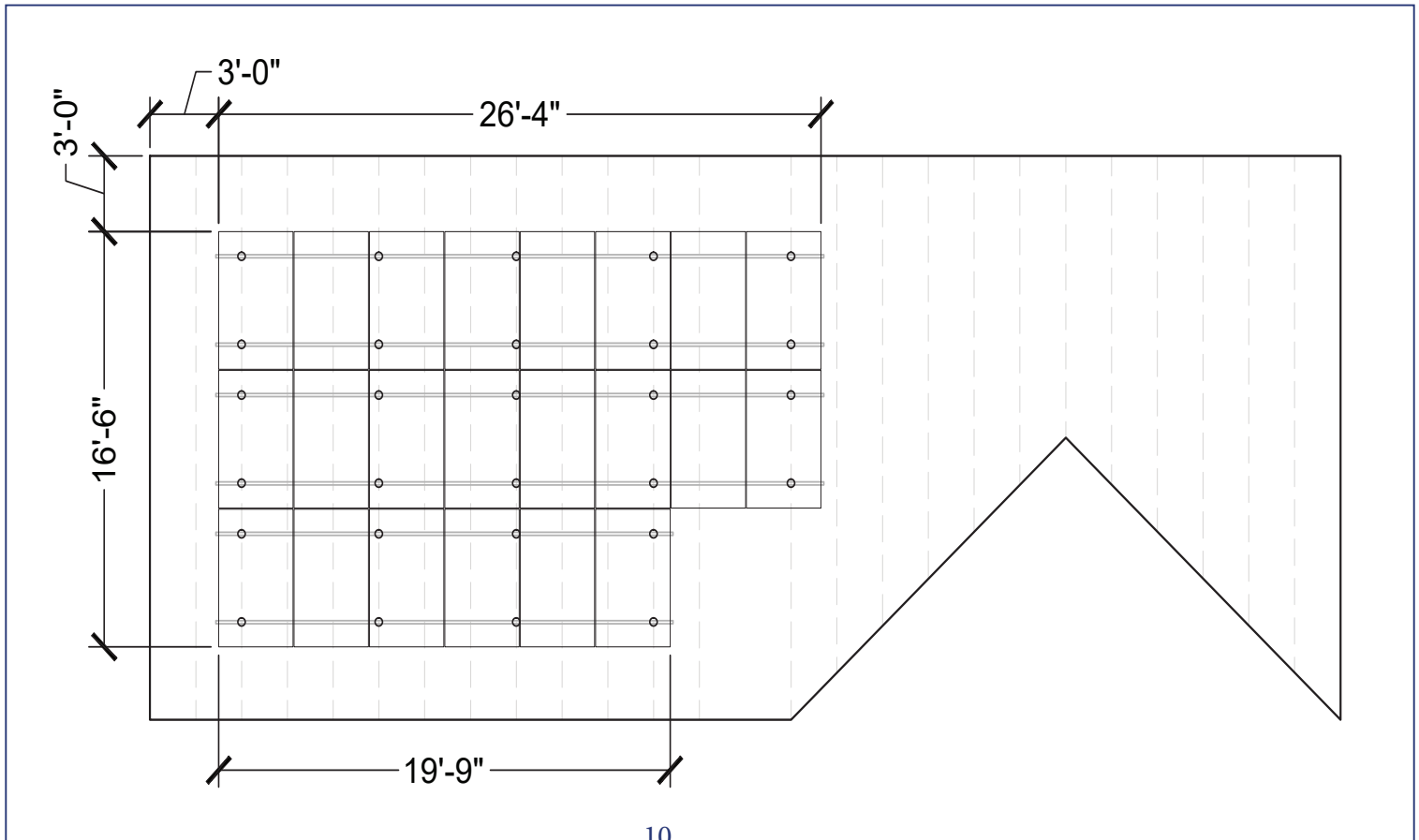

⚙️ Design Note:

Ultra Rail allows for multiple mounting configurations. Modules can be mounted in portrait (long side of module perpendicular to ridge) or landscape (long side of module parallel to ridge) orientations. In addition, modules can also be short side-mounted (module clamps on short side) or long side-mounted (module clamps on long side). Long-side mounting is recommended for maximum material efficiency. Most residential structures utilize roof framing members that run in-slope with the roof, so a portrait orientation with long-side mounting is typically the most efficient use of materials.

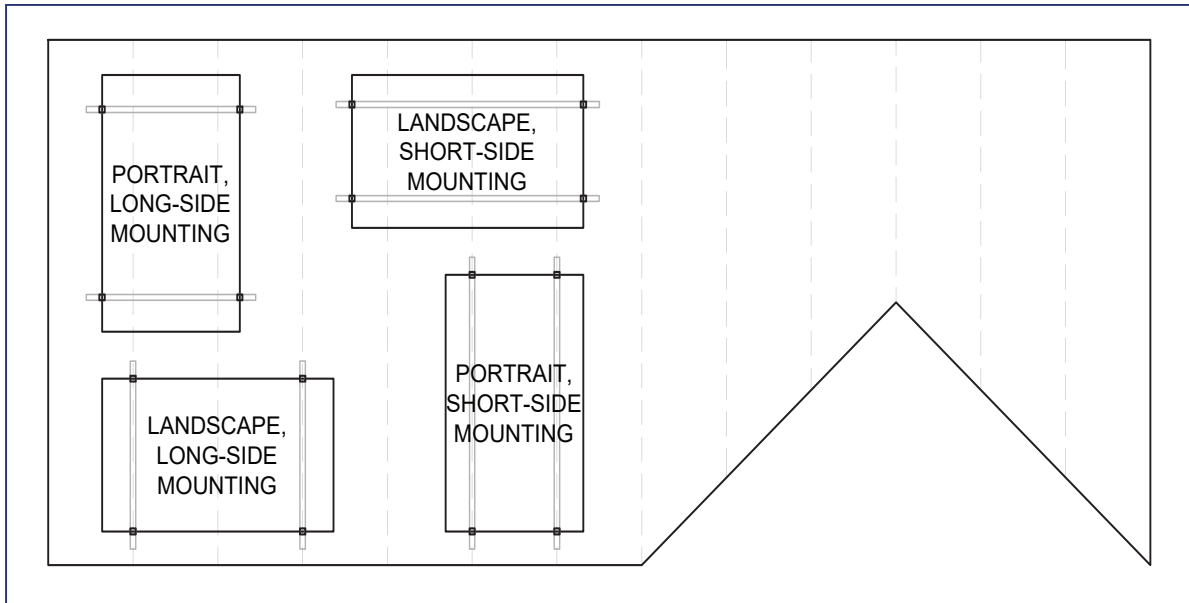

⚙️ Installation Note:

- Ensure the lag screws will be installed in a solid portion of the roof framing member.
- If the roof framing member is not found then seal the pilot hole immediately with roofing sealant.

⚠️ Safety Guidance

- Always wear appropriate OSHA approved safety equipment when at active construction site
- Appropriate fall protection or prevention gear should be used. Always use extreme caution when near the edge of a roof
- Use appropriate ladder safety equipment when accessing the roof from ground level
- Safety equipment should be checked periodically for wear and quality issues
- Always wear proper eye protection

System Layout

- 1) Transfer the array layout to the roof using a roof marking crayon to mark the inside and outside corners of the array.
- 2) Locate the estimated roof framing member positions and mark them in the array area with a roof marking crayon.
- 3) Transfer rail locations using a chalk line.
- 4) Mark roof attachment locations on the roof, noting that attachments will be located at intersections of rails and roof framing members. Layout rails such that module frames do not overhang mounting rails more than specified by module manufacturer, more than 25% of total module length, or more than required by the Class A Fire Certification (see Certification Details section).

Layout Note:

Ensure final roof attachment locations do not exceed the maximum attachment spacing and cantilever specified in the design.

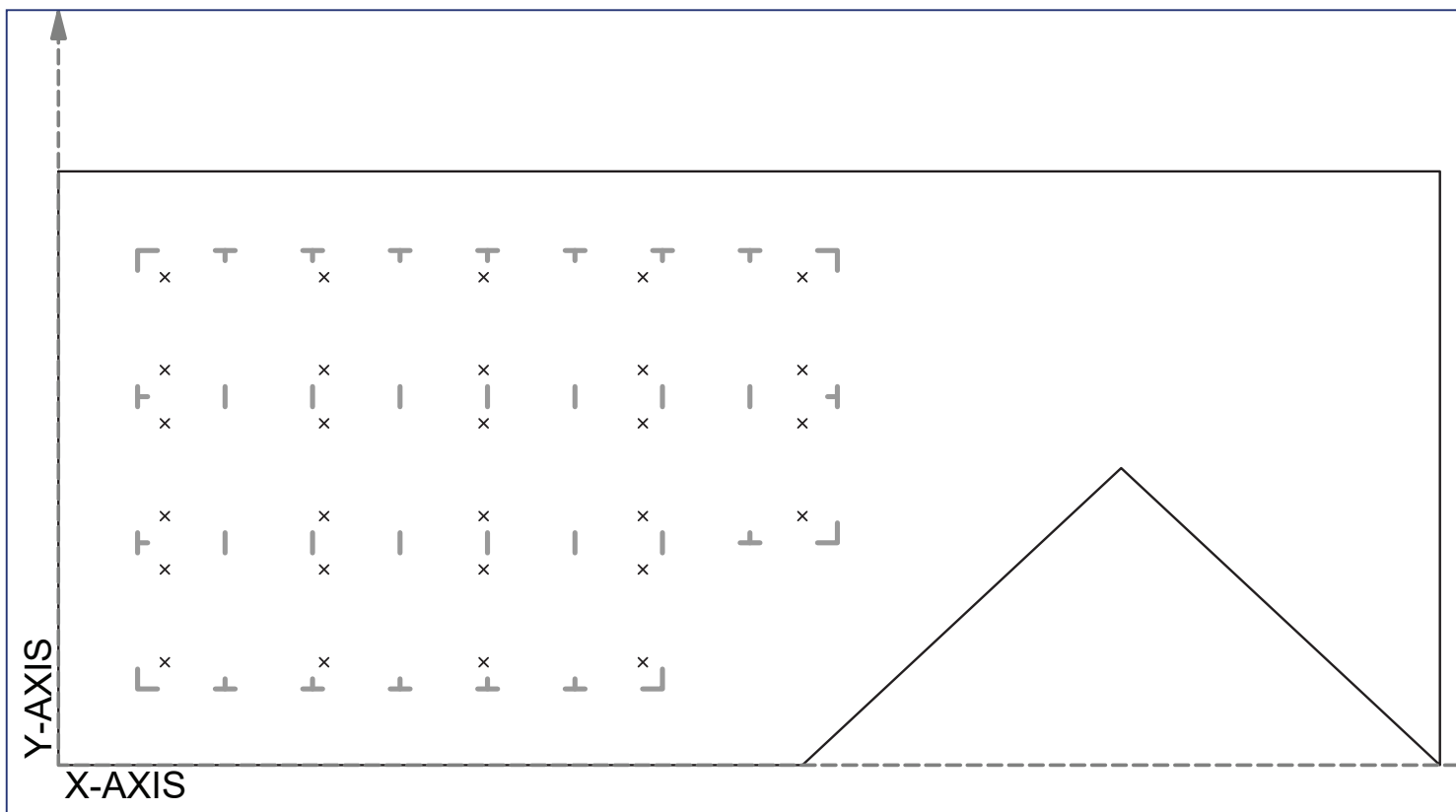

Required Tools

- Hammer or Stud Finder
- Roof Marking Crayon
- Drill with 3/16" Pilot Drill Bit
- Roof Sealant
- Torque Wrench
- Socket Wrench
- 1/2" Socket

Materials Included - L Foot Mount

- (1) SnapNrack Comp Umbrella Flashing
- (1) SnapNrack Umbrella Lag Screw
- (1) SnapNrack Umbrella L Foot
- (1) SnapNrack Ultra Mount (Tapped)
- (1) SnapNrack Ultra Mount (Thru-Hole)
- (1) SnapNrack Ultra Mount Spring
- (1) SnapNrack Ultra Mount Spring Cage
- (1) 5/16"-18 X 2-1/4" SS HCS Bolt

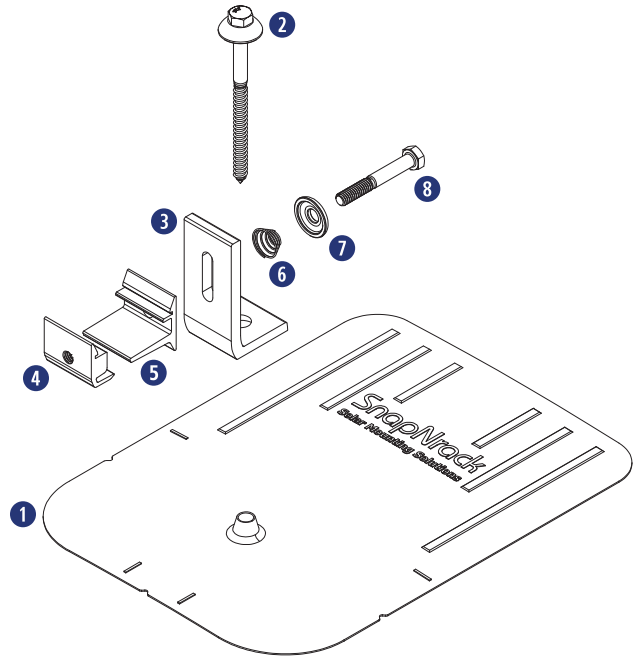

Application Note:
Install on composition shingle roofs.

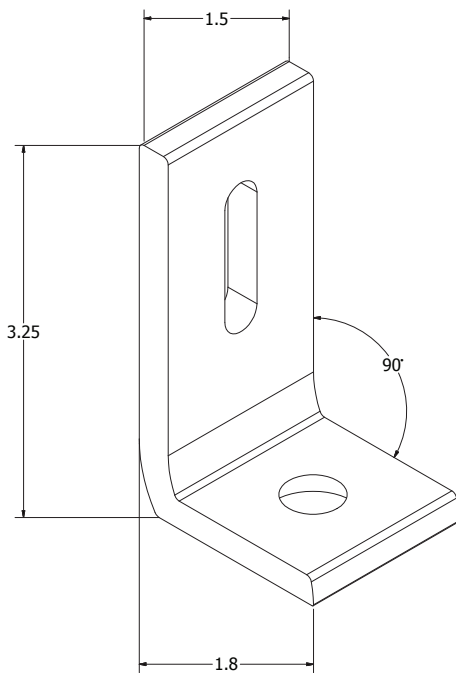

Dimensioned L Foot

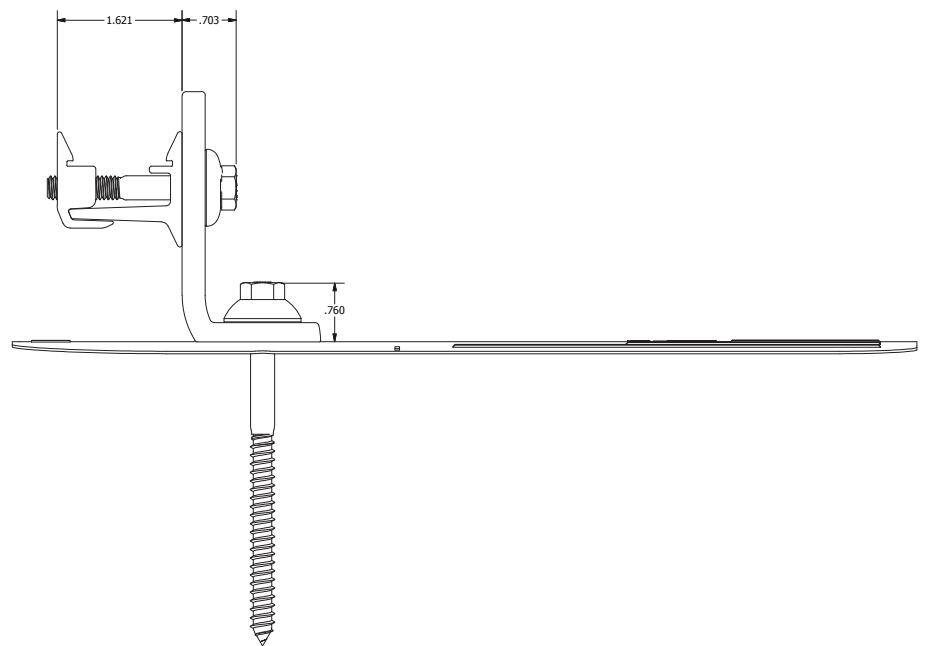

Dimensioned L Foot Assembly

INSTALLATION INSTRUCTIONS

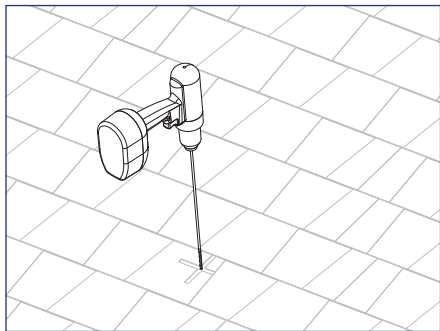

1) Using roof attachment locations drawn during system layout, drill a pilot hole through the roofing material into the roof framing member.

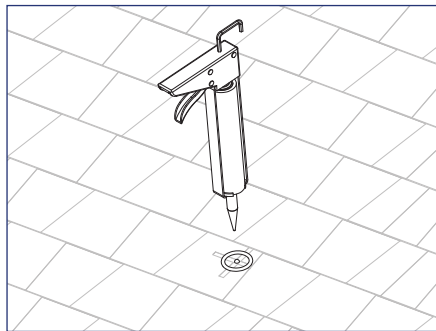

2) Apply roofing sealant in and around the pilot hole, and directly onto the lag screw to ensure a water tight seal.

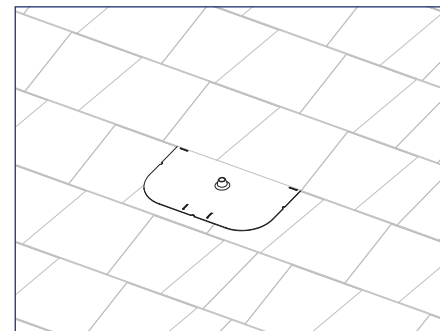

3) Pry up shingles with a breaker bar and install flashing underneath shingle course above pilot hole, and position flashing so cone is in line with pilot hole.



Install Note:

Ensure flashing extends minimum (2) courses above pilot hole, and does not overhang bottom edge of shingle course.

Apply a horseshoe of sealant under flashing to direct water away from penetration.

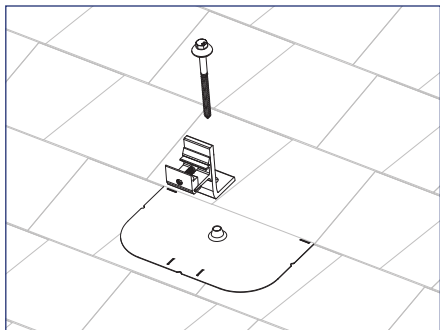

4) Insert Umbrella Lag Screw through Umbrella L Foot and cone in flashing, then drive lag screw for minimum 2.5" embedment into the roof framing member.

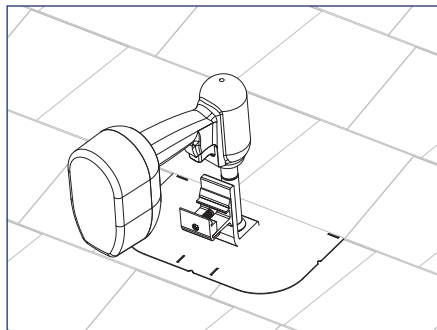

Install Note:

The L Foot can be attached in any orientation.



Best Practice:

If using an impact driver, finish tightening lag screw with a hand wrench to prevent L Foot from rotating.

Required Tools

- Hammer or Stud Finder
- Roof Marking Crayon
- Drill with 3/16" Pilot Drill Bit
- Roof Sealant
- Torque Wrench
- Socket Wrench
- 1/2" Socket

Materials Included - SpeedSeal™ Foot

- ① (1) SnapNrack Sealing Lag Screw
- ② (1) SnapNrack SpeedSeal™ Foot
- ③ (1) SnapNrack Ultra Mount (Tapped)
- ④ (1) SnapNrack Ultra Mount (Thru-Hole)
- ⑤ (1) SnapNrack Ultra Mount Spring
- ⑥ (1) 5/16"-18 X 2" SS Flange Bolt

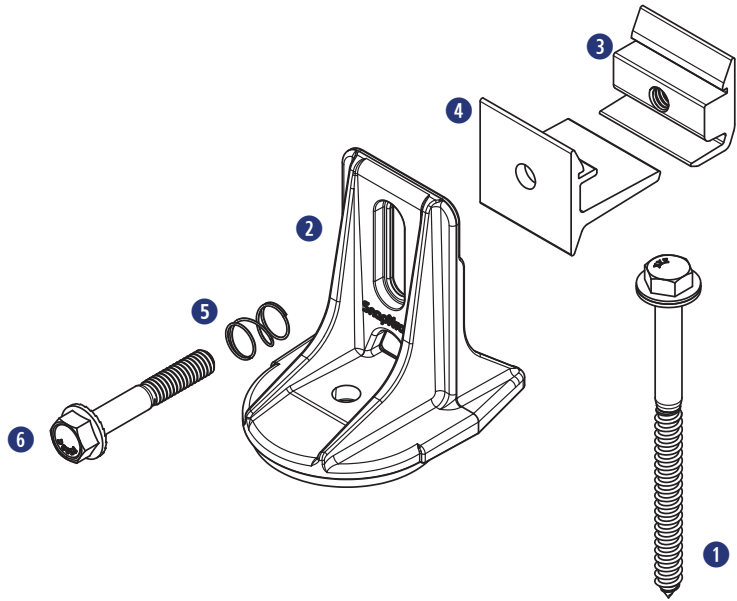

⚙️ Application Note:

Minimum Recommended Roof Slopes:

- Composition Shingle, 9-1/2° (2 : 12)
- Rolled Comp & Membranes, 7°
- May be installed on other compatible Low Slope roofs when appropriate

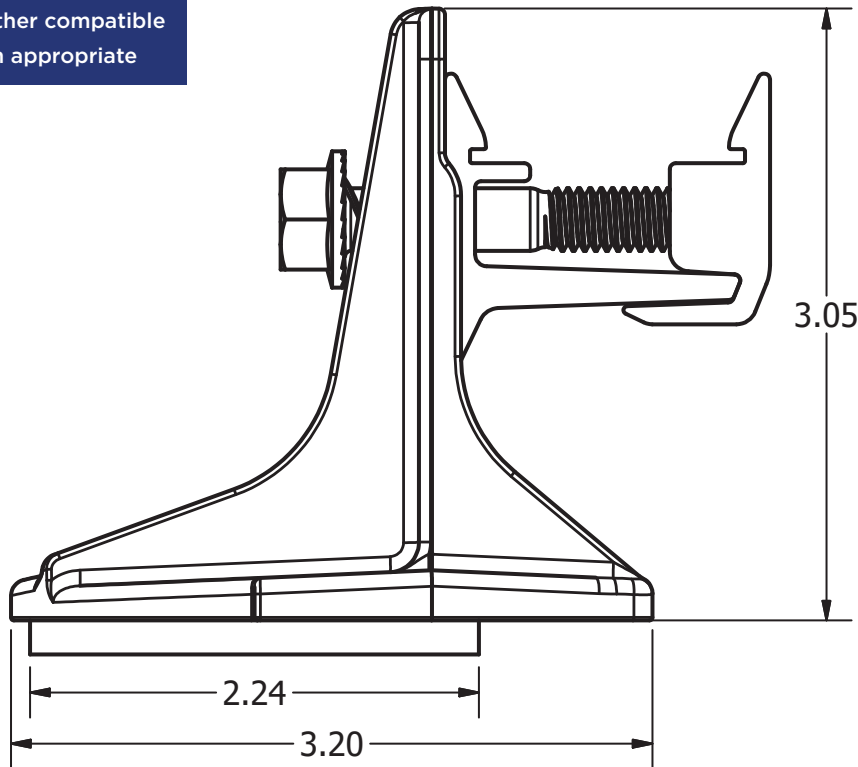

Dimensioned SpeedSeal™ Foot

INSTALLATION INSTRUCTIONS

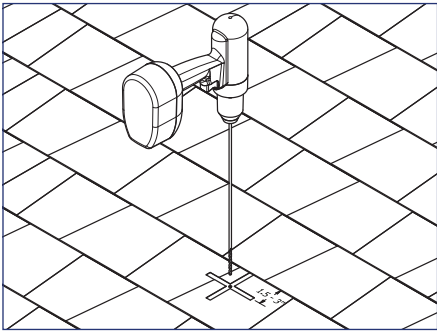

1) Using roof attachment locations drawn during system layout, drill a pilot hole through the roofing material into the roof framing member.

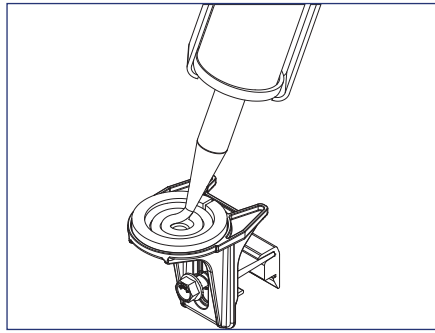

2) Fill cavity on bottom of SpeedSeal™ Foot created by sealant ring with roof sealant, as well as the pilot hole to ensure a water tight seal.

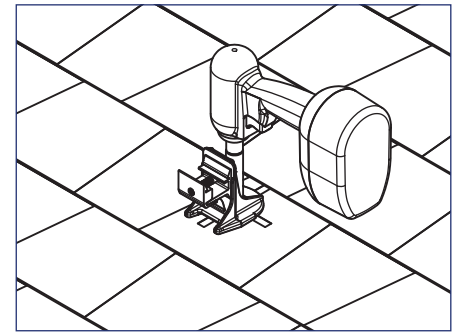

3) Insert sealing lag screw through SpeedSeal™ Foot, then drive lag screw for minimum 2.5" embedment into the roof framing member.

Best Practice:

Pilot hole should be located 1.5" - 3" from edge of shingle course above, and SpeedSeal™ Foot should never be installed across two shingle courses.

Best Practice:

Remove any dirt or debris from roof surface before SpeedSeal™ Foot is installed.

All missed pilot holes should be properly sealed before SpeedSeal™ Foot is installed.

Install Note:

Roof sealant should seep out from the cavity located underneath the Ultra Rail Mount, which ensures that a sufficient amount of roof sealant has been applied. If no sealant is seen, remove SpeedSeal™ Foot and add more sealant before reinstalling.

SpeedSeal™ Foot may be installed in any orientation on the roof.

Best Practice:

If using an impact driver, finish tightening lag screw with a hand wrench to prevent Foot from rotating.

Required Tools

- Roof Marking Crayon
- Roof Sealant & Caulking Gun
- Socket Wrench or Impact Driver
- 3/8" Socket

Materials Included - SpeedSeal™ DeckFoot

- ① (4) SnapNrack #14 Self-Drilling Deck Screw with 3/8" Hex Head & EPDM-Backed Washer
- ② (1) SnapNrack SpeedSeal™ DeckFoot
- ③ (1) SnapNrack Ultra Mount Live Hinge
- ④ (1) SnapNrack Ultra Mount Spring
- ⑤ (1) 5/16"-18 X 1-3/4" SS Flange Bolt

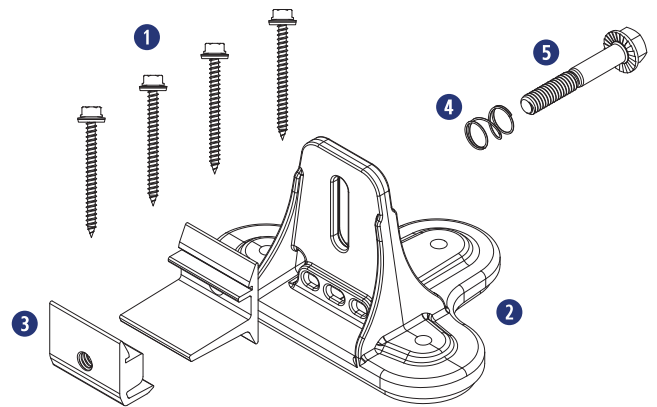

Application Note:

Minimum Recommended Roof Slopes:

- Composition Shingle, 9½° (2 : 12)
- Rolled Comp & Membranes, 7°
- May be installed on other compatible Low Slope roofs when appropriate

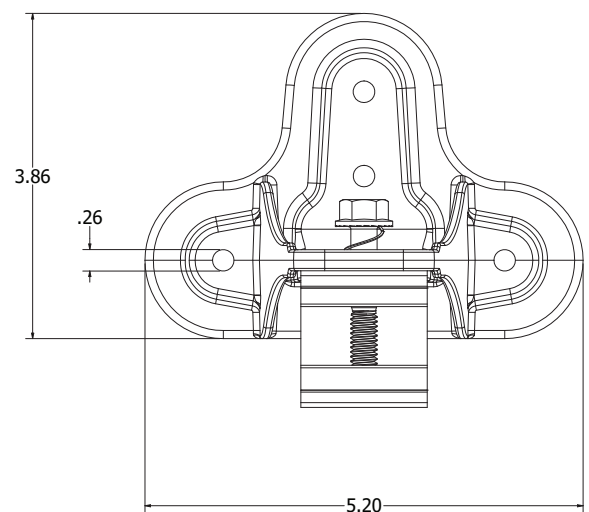
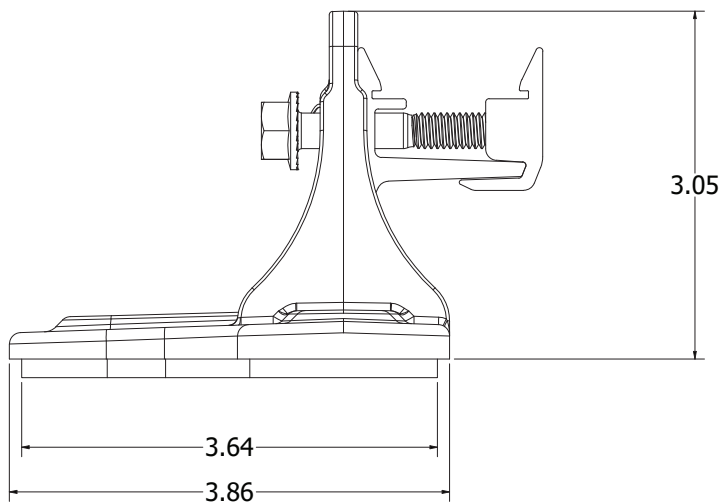

Dimensioned SpeedSeal™ DeckFoot

INSTALLATION INSTRUCTIONS

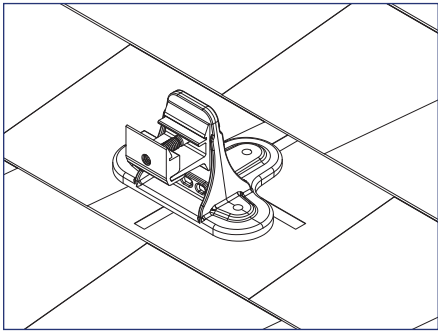

1) Using roof attachment locations drawn during system layout, check positioning of SpeedSeal™ DeckFoot for proper alignment on shingle course.

⚙️ Best Practice:

SpeedSeal™ DeckFoot should never be installed across two shingle courses.

⚙️ Install Note:

Fill any seam in shingles within 4" of a deck screw with sealant prior to installing SpeedSeal™ DeckFoot.

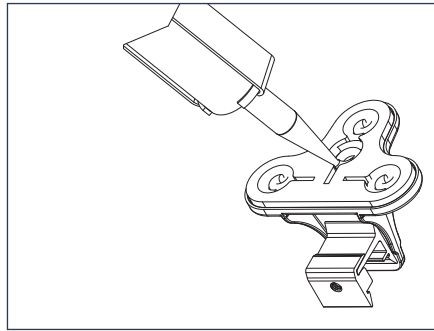

2) Fill all four cavities on bottom of SpeedSeal™ DeckFoot created by sealant ring with roof sealant to ensure a water tight seal.

⚙️ Best Practice:

Remove any dirt or debris from roof surface before SpeedSeal™ DeckFoot is installed.

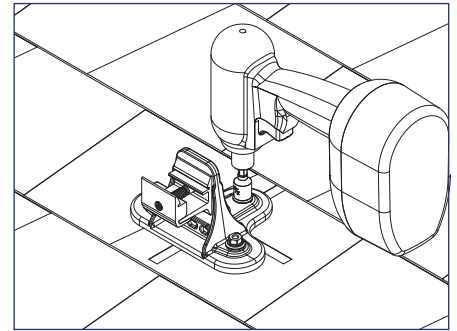

3) Insert first self-drilling deck screw through SpeedSeal™ DeckFoot mounting hole and drive into roof, then repeat for the remaining three screws.

⚙️ Install Note:

Roof sealant should seep out from all three sealant vents located underneath the Ultra Rail Mount, which ensures that a sufficient amount of roof sealant has been applied. If sealant is not seen from all three vents, remove SpeedSeal™ DeckFoot and add more sealant before reinstalling.

SpeedSeal™ DeckFoot may be installed in any orientation on the roof.

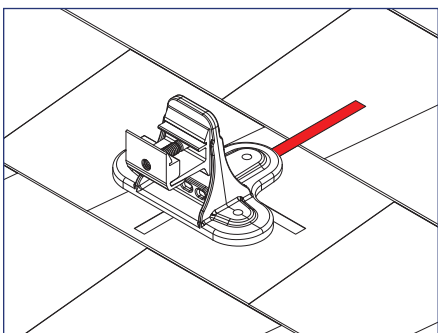

4) **Optional rafter attachment step:** After locating and marking rafters on the roof use four (4) ¼" x 2½" SS lag screws and washers to attach the DeckFoot to rafters and decking by following steps 1-3 above. The two lag screws in the center of the DeckFoot must be embedded into the rafter.

Required Tools

- Hammer or Stud Finder
- Roof Marking Crayon
- Drill with 3/16" Pilot Drill Bit
- Roof Sealant
- Torque Wrench
- Socket Wrench
- 1/2" Socket
- Flat Pry Bar
- Tape Measure

Materials Included - Ultra Rail Tile Hook F

- ① (1) SnapNrack Ultra Rail Flat Tile Hook
- ② (1) 5/16"-18 x 1-3/4" SS Flange Bolt
- ③ (1) SnapNrack Ultra Mount Spring Cage
- ④ (1) SnapNrack Ultra Mount Spring
- ⑤ (1) SnapNrack Ultra Mount (Thru-Hole)
- ⑥ (1) SnapNrack Ultra Mount (Tapped)

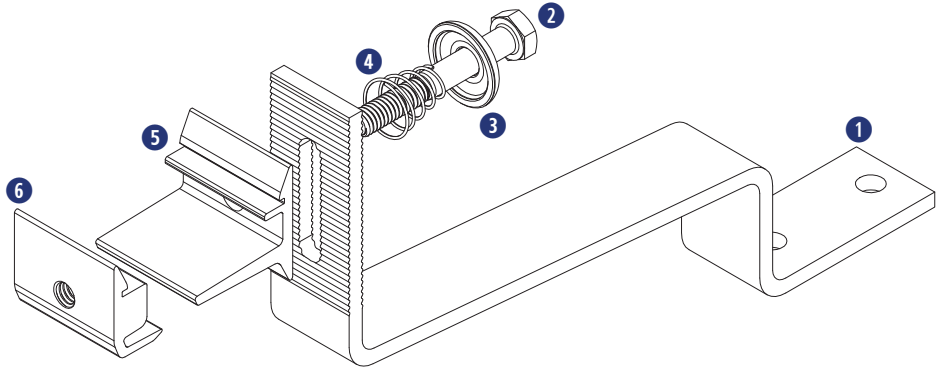

Other Materials Required (Not Shown)

- ① (2) 5/16" Lag Screw
- ② (2) 5/16" Washer
- ③ Flexible Flashing (when required for deck level flashing)

Application Note:
Install on flat concrete tile roofs.

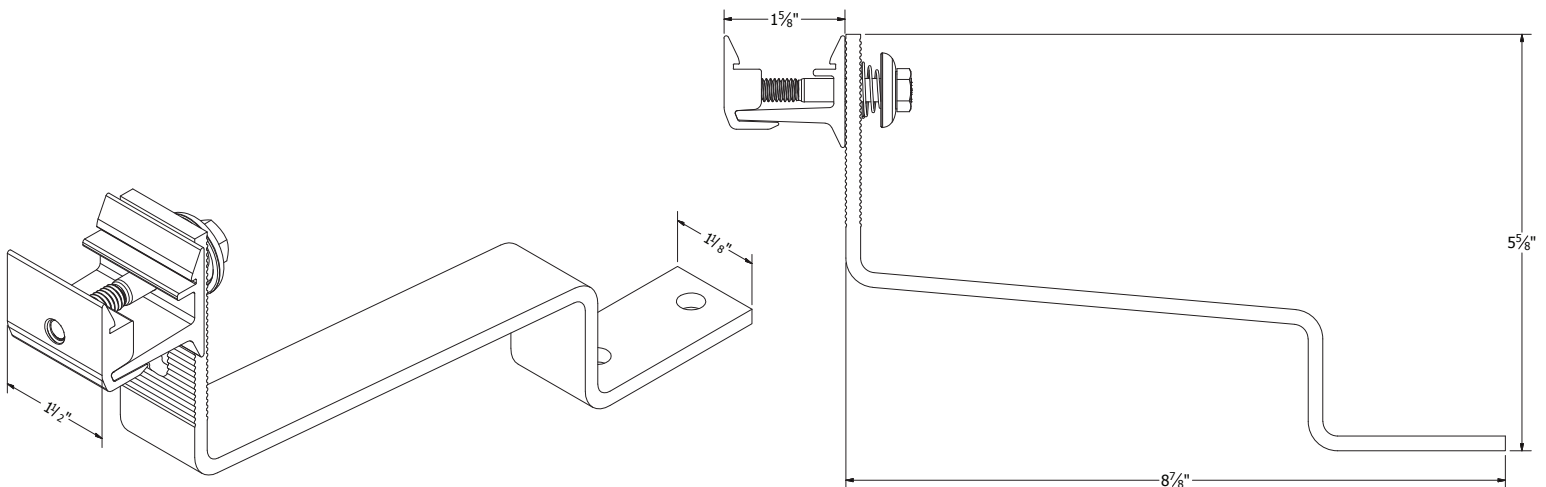

Dimensioned Ultra Rail Tile Hook F Assembly

INSTALLATION INSTRUCTIONS

1) Using roof attachment locations drawn during system layout, remove roof tile where the roof attachment will be installed.

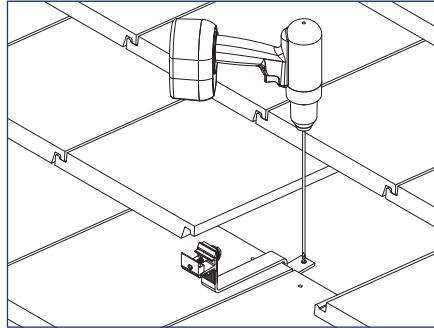

2) Align the hook over the rafter and drill two pilot holes through the roofing material into the roof framing member.

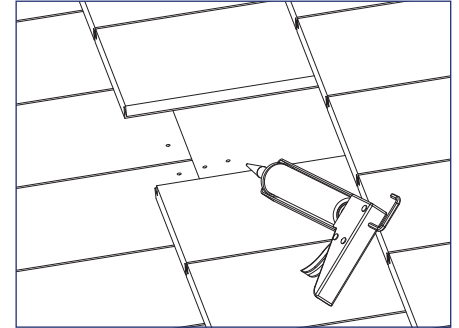

3) Apply roofing sealant to pilot holes and Tile Hook.

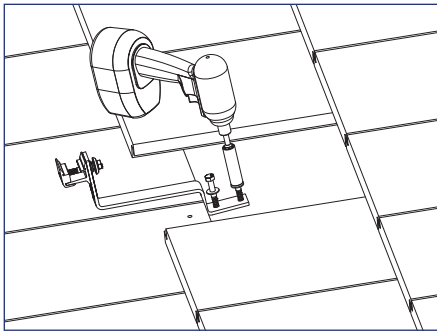

4) Attach the base with (2) 5/16" lag screws, drive lag screws for minimum 2.5" embedment into the roof framing member.

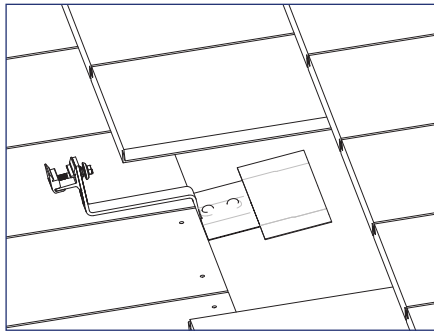

5) If deck level flashing is required, install flexible flashing per the following instructions.

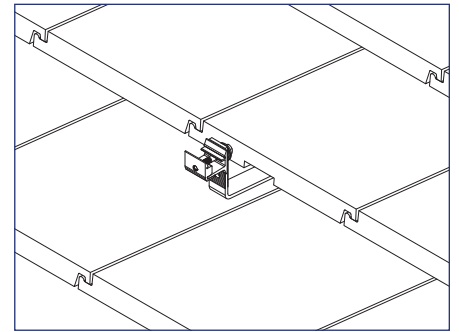

6) Replace tile

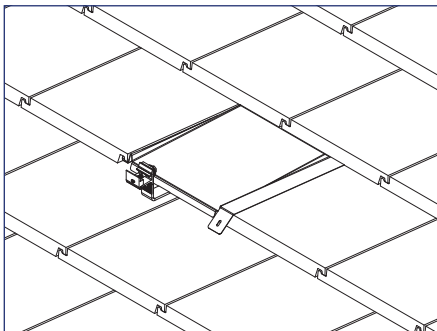

7) **OPTIONAL:** Install Tile Replacement flashing in place of roof tile over tile hook.

Best Practice:

Mold or slightly trim flashing around hook to achieve desired fitment.

Required Tools

- Hammer or Stud Finder
- Roof Marking Crayon
- Drill with 3/16" Pilot Drill Bit
- Roof Sealant
- Torque Wrench
- Socket Wrench
- 1/2" Socket
- Flat Pry Bar
- Tape Measure

Materials Included - Ultra Rail Tile Hook WS

- ① (1) SnapNrack Ultra Rail Tile Hook WS
- ② (1) 5/16"-18 x 1-3/4" SS Flange Bolt
- ③ SnapNrack Ultra Mount Spring Cage
- ④ (1) SnapNrack Ultra Mount Spring
- ⑤ (1) SnapNrack Ultra Mount (Thru-Hole)
- ⑥ (1) SnapNrack Ultra Mount (Tapped)

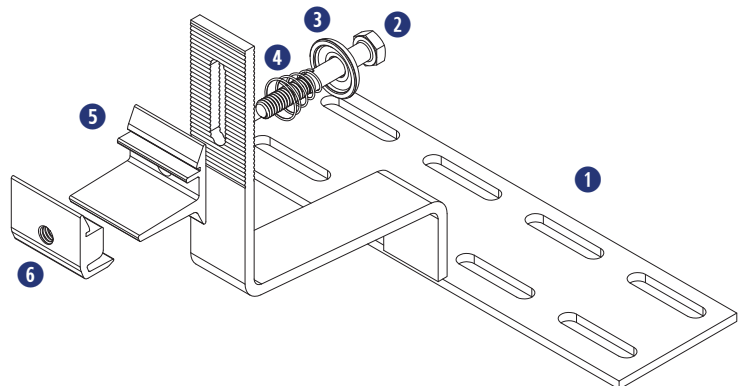

Other Materials Required (Not Shown)

- ① (2) 5/16" Lag Screw
- ② (2) 5/16" Washer
- ③ Flexible Flashing (when required for deck level flashing)



Application Note:

Install on W and S style concrete tile roofs.

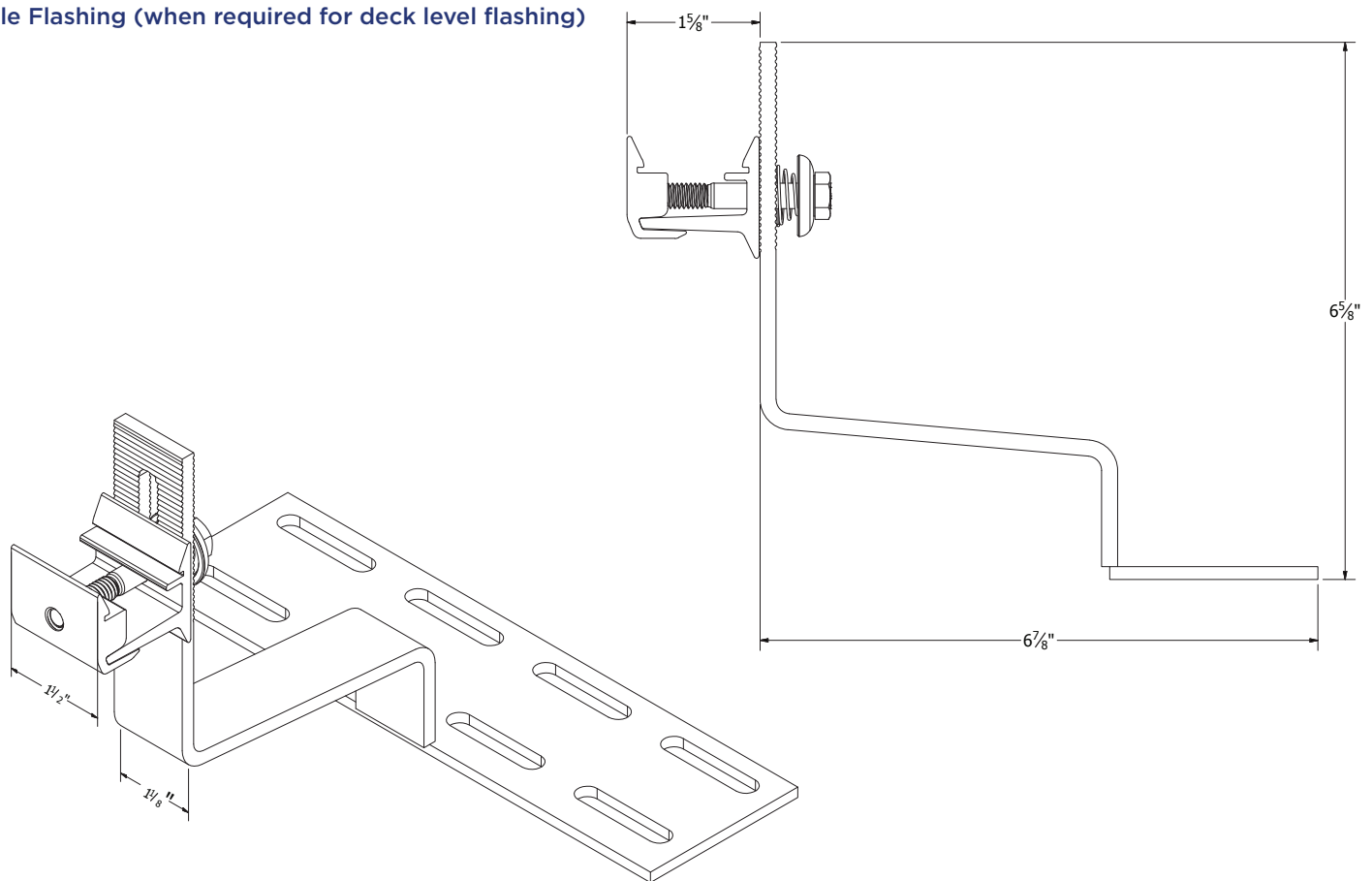

Dimensioned Ultra Rail Tile Hook WS Assembly

INSTALLATION INSTRUCTIONS

1) Using roof attachment locations drawn during system layout, remove roof tile where the roof attachment will be installed.

Install Note:

A neighboring tile may need to be removed to attach to the roof framing member and line up hook with the tile.

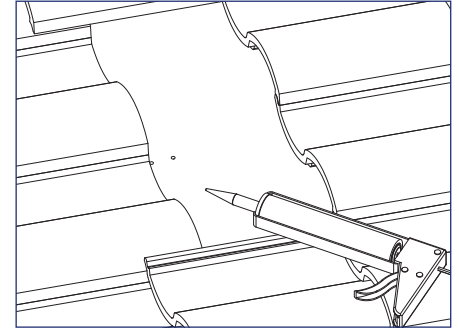
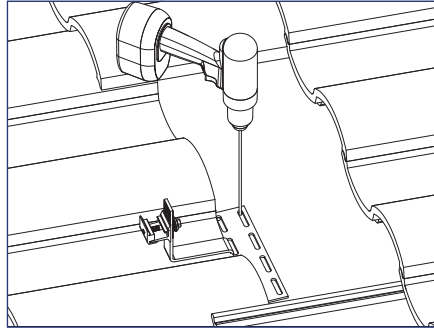

2) Align the base over the rafter so the hook can enter at the valley of a tile (W and S Tile). Drill two pilot holes through the roofing material into the roof framing member.

3) Apply roofing sealant to pilot holes and Tile Hook base.

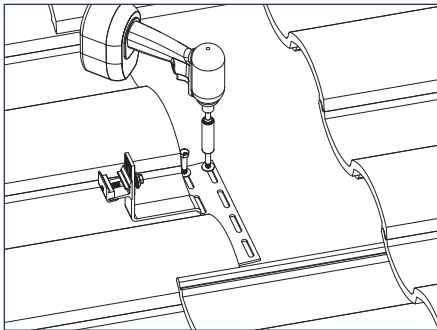

4) Attach the base with (2) 5/16" lag screws, drive lag screws for minimum 2.5" embedment into the roof framing member.

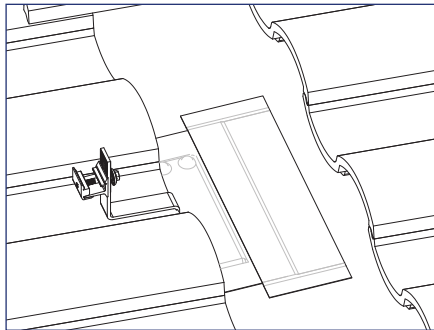

5) If deck level flashing is required, install flexible flashing per the following instructions.

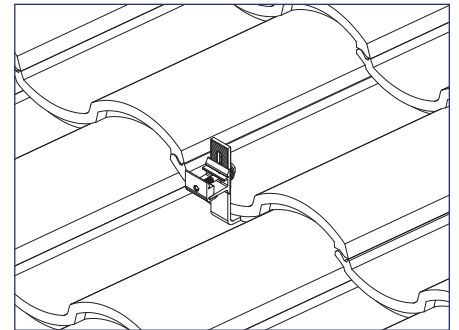

6) Replace tile

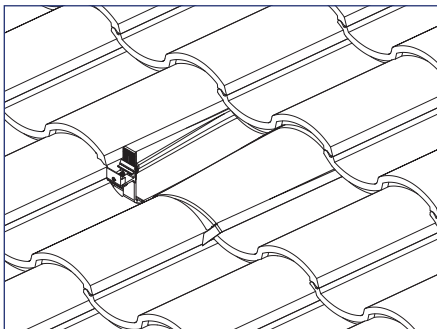

7) **OPTIONAL:** Install Tile Replacement flashing in place of roof tile over tile hook.

Best Practice:

Mold or slightly trim flashing around hook to achieve desired fitment.

Required Tools

- Hammer Or Stud Finder
- Roof Marking Crayon
- Drill with 3/16" Pilot Drill Bit
- Torque Wrench
- Socket Wrench
- 1/2" Socket

Materials Included - Metal Roof Base

- ① (1) SnapNrack Metal Roof Base
- ② (1) SnapNrack All Purpose L Foot
- ③ (1) 5/16"-18 SS Flange Nut
- ④ (1) SnapNrack Ultra Mount (Tapped)
- ⑤ (1) SnapNrack Ultra Mount (Thru-Hole)
- ⑥ (1) SnapNrack Ultra Mount Spring
- ⑦ (1) SnapNrack Ultra Mount Spring Cage
- ⑧ (1) 5/16"-18 X 2-1/4" SS HCS Bolt

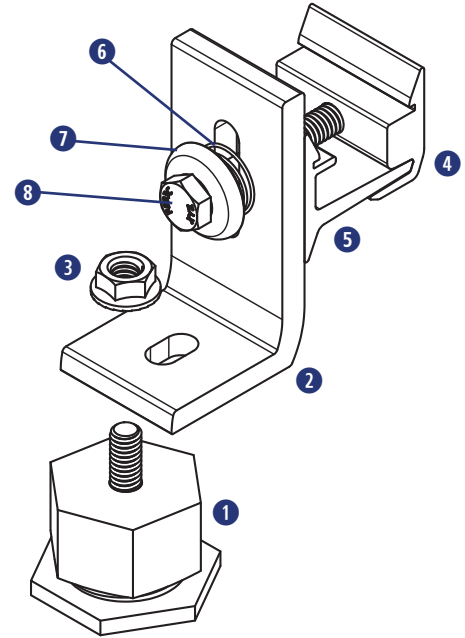

Other Materials Required - Not Shown

- ① (1) 5/16" Lag Screw or 1/4" Self-Drilling Screw
- ② (1) 5/16" or 1/4" Washer (3/4" max O.D.)

Application Note:
Install on metal roof profiles with flat surface large enough to accommodate 1-5/8" wide base

Installation Note:
Grounding and bonding of mounting system to metal roof panels shall meet local AHJ requirements.

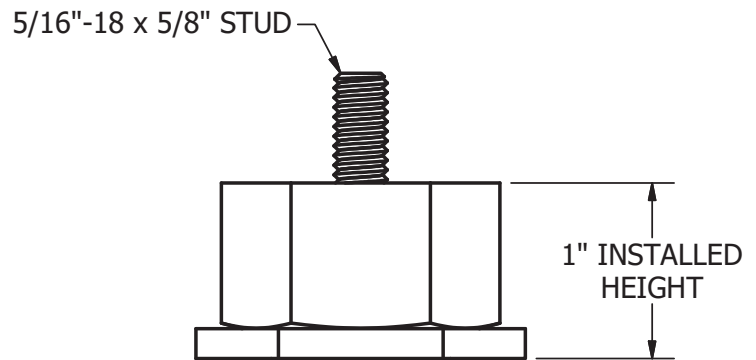
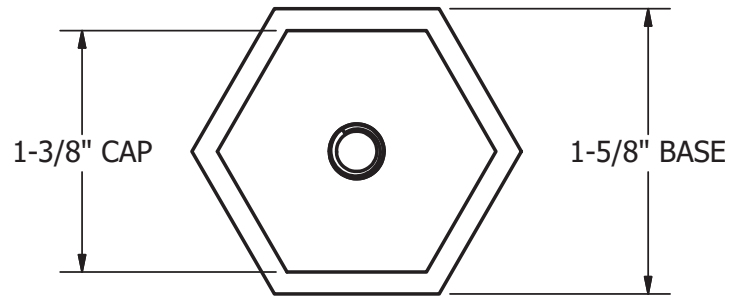

Dimensioned Metal Roof Base Assembly

INSTALLATION INSTRUCTIONS

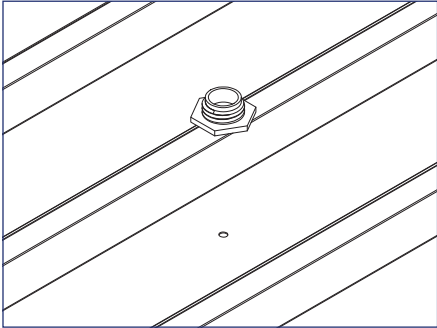

1) Using roof attachment locations drawn during system layout, drill a pilot hole through the roofing material into the roof framing member.

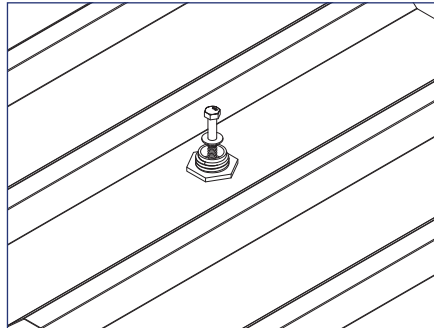

2) Attach the base with 5/16" lag screw (or 1/4" self-drilling screw for metal structures), drive screw for minimum 2.5" embedment into the roof framing member.

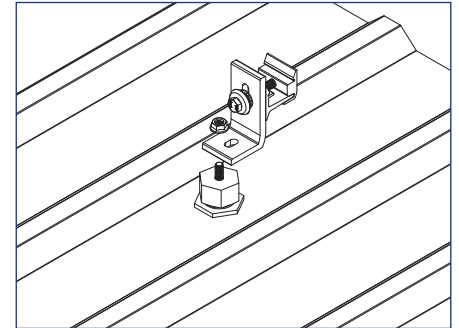

3) Thread Metal Roof Base cap onto Metal Roof Base bottom, ensuring cap is fully seated to base.



Install Note:

Take care to ensure the base does not twist when cap is tightened.



Install Note:

Ensure area is free from metal shavings and debris before installing Metal Roof Base. Metal roofs with excessive debris, corrosion, or non-factory coating should be evaluated for adequate sealing surface.

Additional roof sealant not required but can be applied after tightening the Metal Roof Base to roof, if desired.

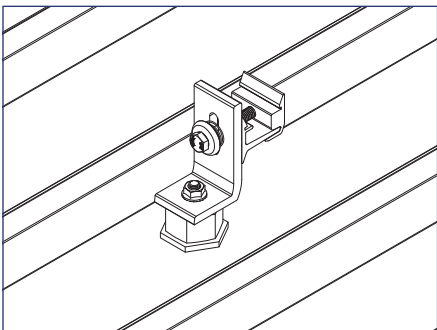

4) Attach L Foot to stud in Metal Roof Base cap and tighten hardware to 10 ft-lbs.



Best Practice:

Finish tightening hardware with a hand wrench to prevent L Foot from rotating.

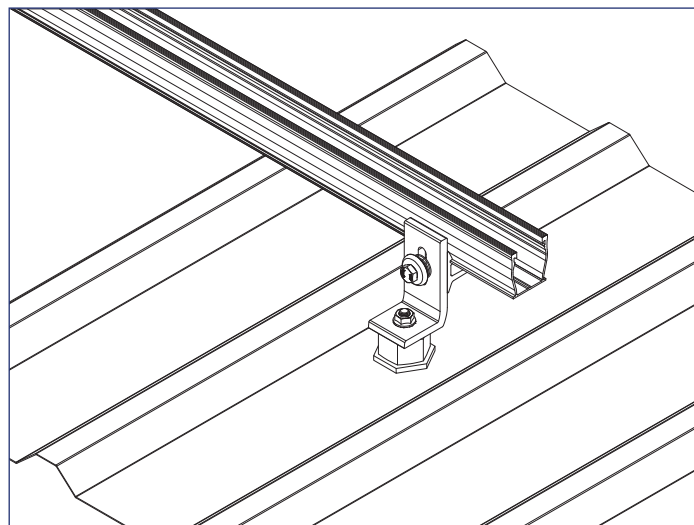

Required Tools

- Hammer Or Stud Finder
- Drill with 3/16" Pilot Drill Bit
- Roof Sealant
- Torque Wrench
- Socket Wrench
- 1/2" Socket

Materials Included - Corrugated Straddle Block

- ① (1) SnapNrack Corrugated Straddle Block
- ② (1) SnapNrack All Purpose L Foot
- ③ (1) SnapNrack Ultra Mount (Tapped)
- ④ (1) SnapNrack Ultra Mount (Thru-Hole)
- ⑤ (1) SnapNrack Ultra Mount Spring
- ⑥ (1) SnapNrack Ultra Mount Spring Cage
- ⑦ (1) 5/16"-18 X 2-1/4" SS HCS Bolt

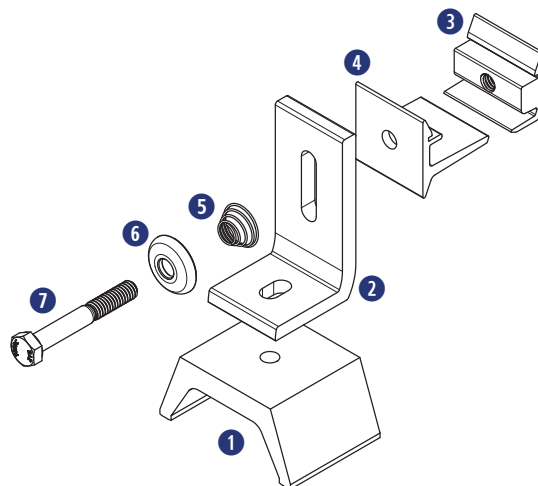

Other Materials Required - *Not Shown*

- ① (1) 5/16" Lag Screw or 1/4" Self-Drilling Screw
- ② (1) Washer

Application Note:
Use self-drilling screw for steel roofing members, lag screw for wooden roof framing members

Application Note:
Install on sinusoidal style corrugated metal roofs

Installation Note:
Grounding and bonding of mounting system to metal roof panels shall meet local AHJ requirements.

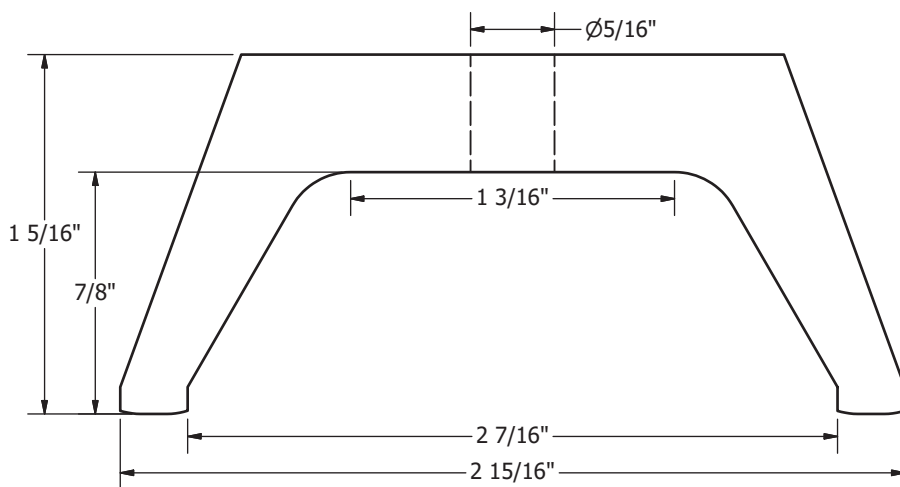

Dimensioned Corrugated Straddle Block

INSTALLATION INSTRUCTIONS

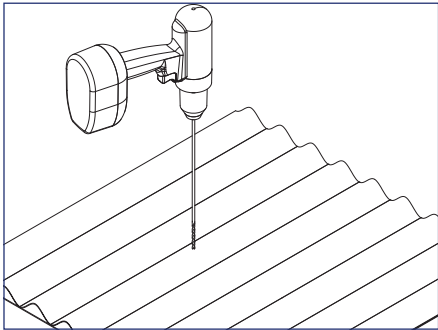

1) Using roof attachment locations drawn during system layout, drill a pilot hole through the high point of the roofing material into the roof framing member.

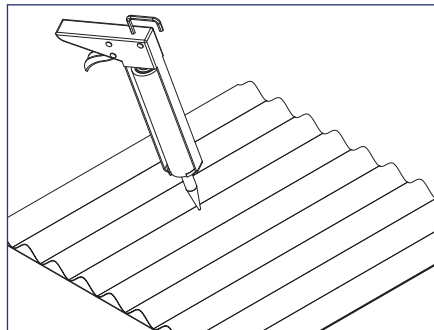

2) Apply roofing sealant directly onto the pilot hole and the lag to ensure a water tight seal.

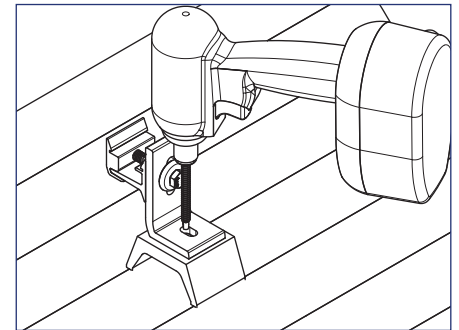

3) Attach the Straddle Block and L Foot with 5/16" lag screw (or 1/4" self-drilling screw for metal structures), drive screw for minimum 2.5" embedment into the roof framing member.

Install Note:

Ensure the lag or self-drilling screws will be installed in a solid portion of the roof framing member.

If the roof framing member is not found then seal the pilot hole immediately with roofing sealant.

Best Practice:

If using an impact driver, finish tightening lag screw with a hand wrench to prevent L Foot from rotating.

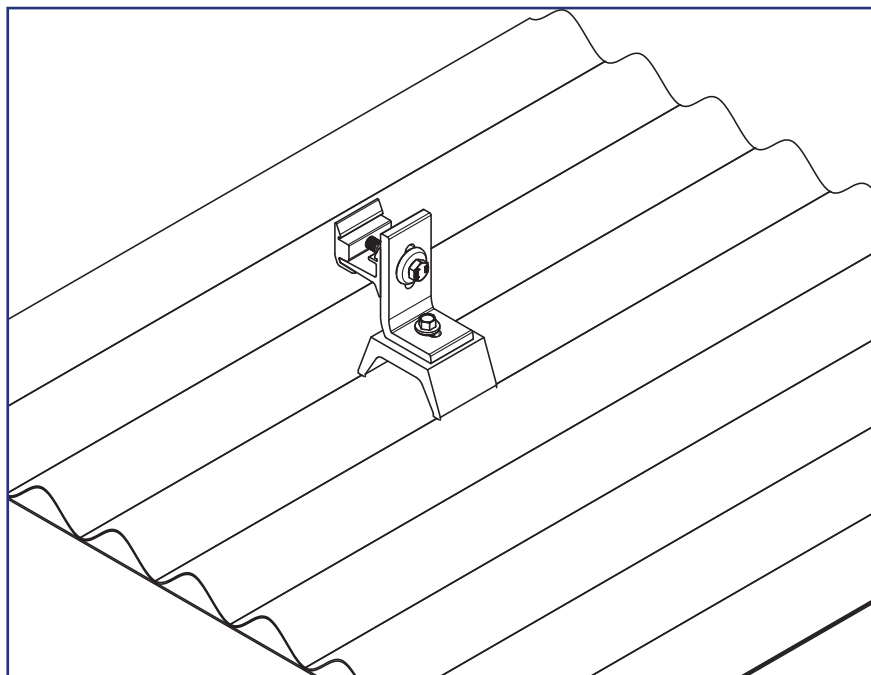

Required Tools

- Torque Wrench
- Socket Wrench
- 1/2" Socket

Materials Included - Standard Base Seam Clamp Kit

- ① (1) 5/16"-18 X 1-1/2" SS HCS Bolt (Black)
- ② (1) 5/16" SS Split Lock Washer
- ③ (1) SnapNrack Seam Clamp Insert
- ④ (1) SnapNrack Seam Clamp Cam
- ⑤ (1) SnapNrack Seam Clamp Standard Base
- ⑥ (1) SnapNrack All Purpose L Foot
- ⑦ (1) SnapNrack Rotation Lock
- ⑧ (1) SnapNrack Ultra Mount (Tapped)
- ⑨ (1) SnapNrack Ultra Mount (Thru-Hole)
- ⑩ (1) SnapNrack Ultra Mount Spring
- ⑪ (1) SnapNrack Ultra Mount Spring Cage
- ⑫ (1) 5/16"-18 X 2-1/4" SS HCS Bolt

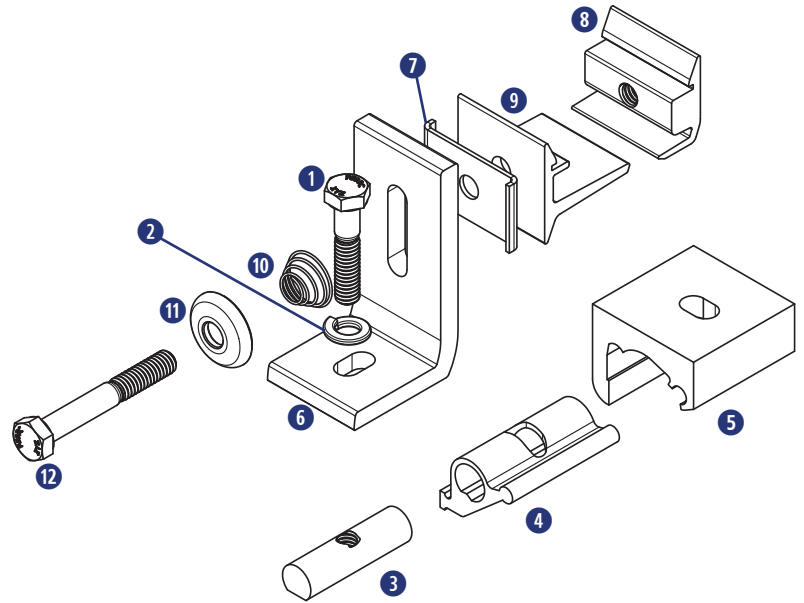

Materials Included - Wide Base Seam Clamp Kit

- ① (1) 5/16"-18 X 1-1/2" SS HCS Bolt (Black)
- ② (1) 5/16" SS Split Lock Washer
- ③ (1) SnapNrack Seam Clamp Insert
- ④ (1) SnapNrack Seam Clamp Cam
- ⑤ (1) SnapNrack Seam Clamp Wide Base
- ⑥ (1) SnapNrack All Purpose L Foot
- ⑦ (1) SnapNrack Rotation Lock
- ⑧ (1) SnapNrack Ultra Mount (Tapped)
- ⑨ (1) SnapNrack Ultra Mount (Thru-Hole)
- ⑩ (1) SnapNrack Ultra Mount Spring
- ⑪ (1) SnapNrack Ultra Mount Spring Cage
- ⑫ (1) 5/16"-18 X 2-1/4" SS HCS Bolt

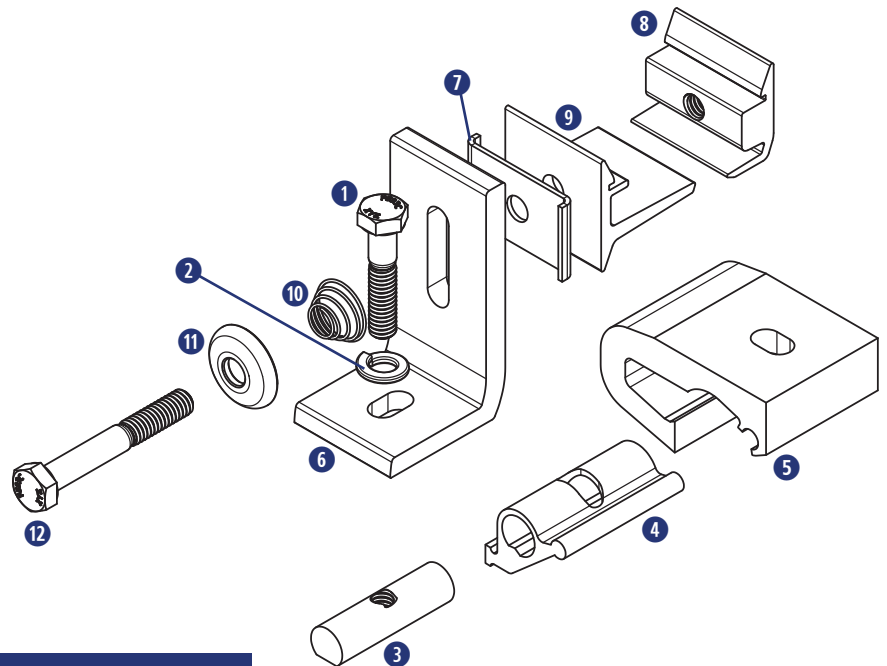

Application Note:
Install on standing metal seam roofs

Installation Note:
Grounding and bonding of mounting system to metal roof panels shall meet local AHJ requirements.

INSTALLATION INSTRUCTIONS

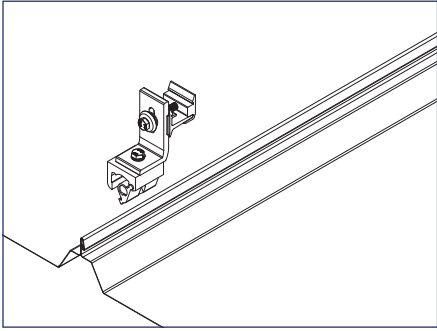

1) Loosen seam clamp hardware and use roof attachment locations to lay out seam clamps on roof.

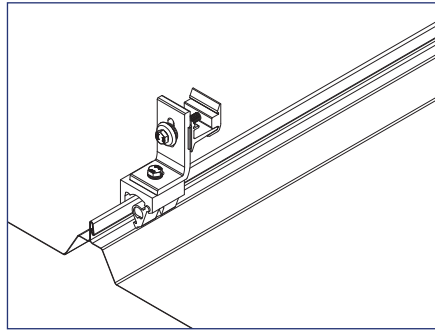

2) Attach the seam clamp to the standing metal seam by opening the seam clamp cam and placing the clamp over the top of the standing metal seam.

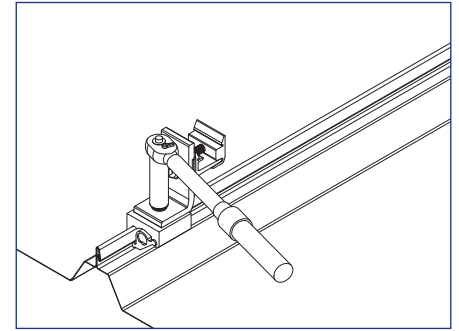

3) Torque black seam clamp bolt to 15-16 ft-lbs.



Install Note:

Seam clamps should never be installed using an impact driver.

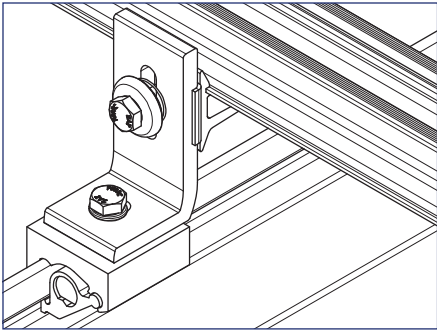

4) Ensure rotation lock is properly aligned with Ultra Mount and L foot during rail installation.

SnapNrack Seam Clamps have been designed to work with a variety of standing seam metal roofs, the most common seam types are:

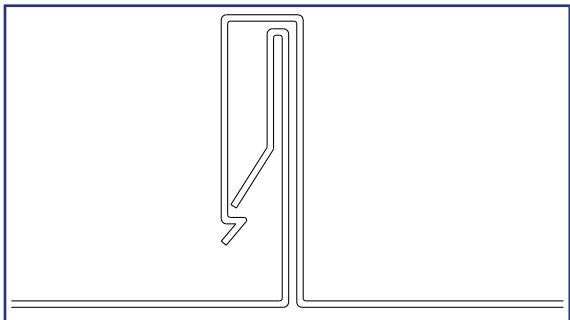

Snap Lock

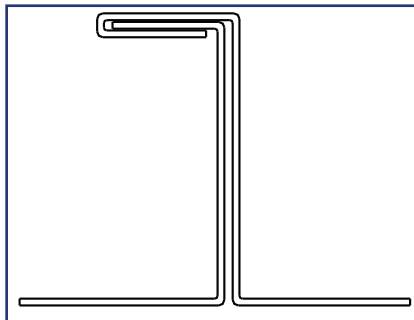

Single Lock

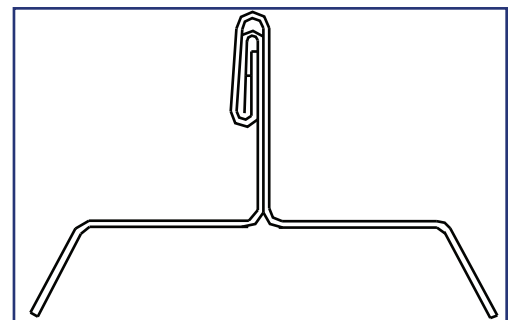

Double Lock



Install Note:

If a specific roof seam is not found on list, contact SnapNrack prior to installation.

Required Tools

- Torque Wrench
- Socket Wrench
- 1/2" Socket

Materials Included - Ultra Rail Mounting Hardware

- ① (1) SnapNrack Ultra Mount (Tapped)
- ② (1) SnapNrack Ultra Mount (Thru-Hole)
- ③ (1) SnapNrack Ultra Mount Spring
- ④ (1) SnapNrack Ultra Mount Spring Cage
- ⑤ (1) 5/16"-18 X 2-1/4" SS HCS Bolt

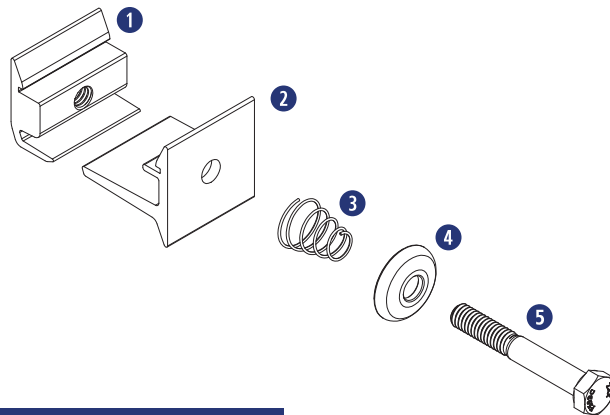

Other Materials Required - *Not Shown*

- ① Roof Attachment

 **Application Note:**
Install Ultra Rail onto any roof attachment that uses an L foot or other slotted mount that accepts 5/16" hardware.

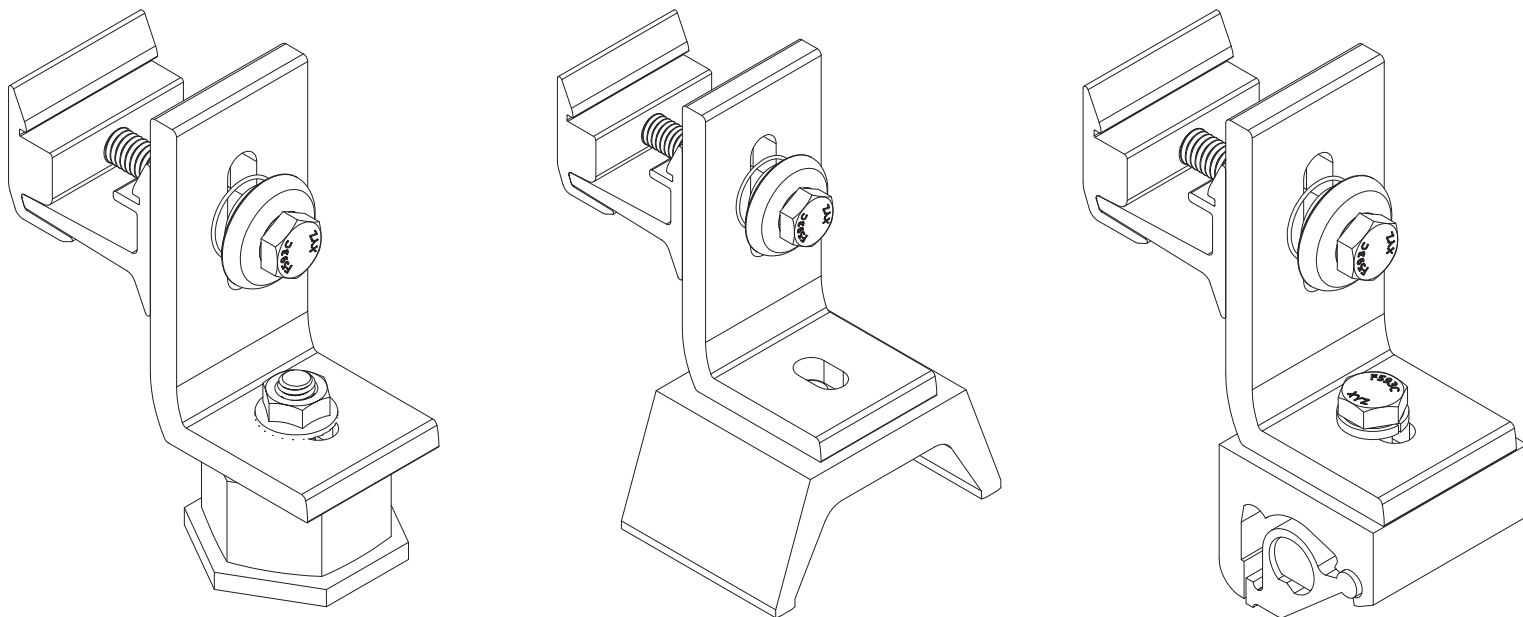

Ultra Rail Mounting Hardware Installed on Different Roof Attachments

 **Install Note:**
Roof attachments used must always meet minimum structural requirements. Consult licensed structural engineer if necessary.

INSTALLATION INSTRUCTIONS

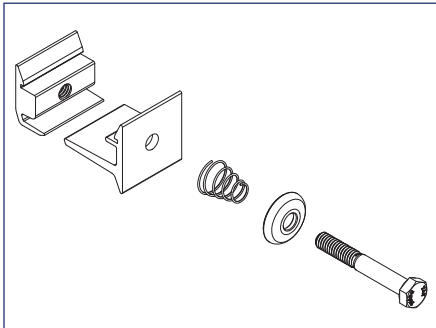

1) Disassemble Ultra Rail Mounting Hardware components, taking note of their installation order and orientation.



Install Note:

See exploded view on previous page for clarification.

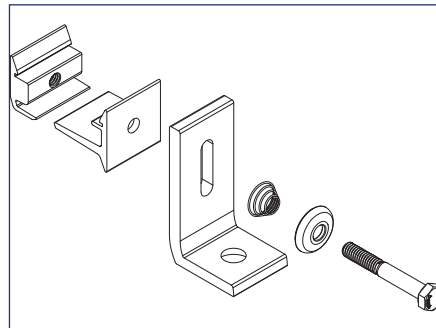

2) Re-assemble Ultra Rail Mounting Hardware components onto roof attachment in the following order:

Ultra Mount (tapped) - Ultra Mount (thru-hole) - roof attachment - spring - spring cage - bolt



Best Practice:

Ensure bolt is threaded into mount, but leave assembly loose for rail installation.

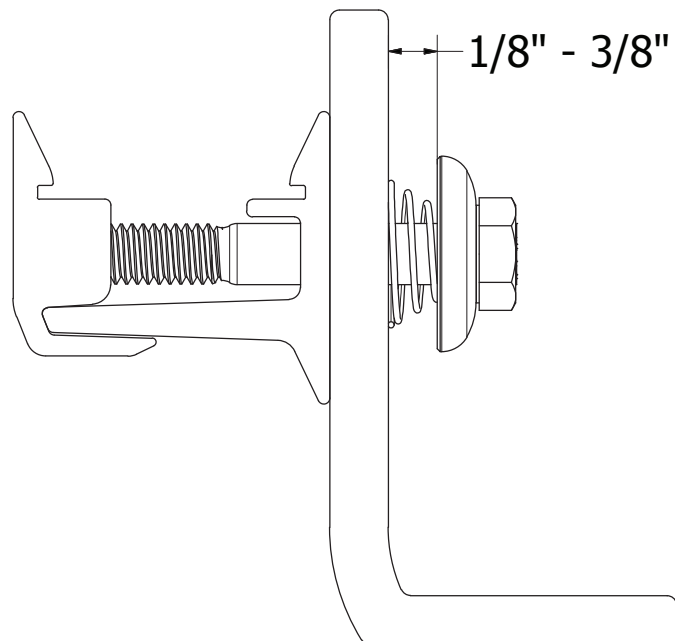

Recommended Ultra Rail Mounting Hardware Installation

⚙️ Note:

Installation of OmniBase on Flat roofs described in this Section pertains to Flush Mounted Standoff Mounts as well as Fixed Tilt Mounts

Required Tools

- Hammer or Stud Finder
- Roof Marking Crayon
- Drill with 3/16" Pilot Drill Bit (wood roof structures)
- Roof Sealant
- Socket Wrench
- Torque Wrench
- 1/2" Socket
- Tape Measure
- Pitch Finder Tool (Inclinometer)

Materials Included - Ultra Rail Standoff Tilt Kits

- ① (2) SnapNrack OmniBase™
- ② (1) Standoff with Ultra Rail Tilt Clamp, 5 1/2" or 10" (front leg)
- ③ (1) Standoff with Ultra Rail Tilt Clamp, 10", 14" or 23" (rear leg)

⚙️ Note:

OmniBase™ and Standoffs with Ultra Rail Tilt Clamp are kitted and are ordered as a unit.

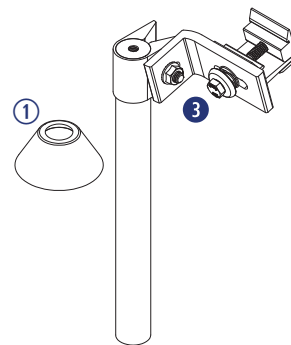

Other Materials Required - Not Shown

Fasteners (see list of fasteners under Installation Sequence #2 on following page)

(2) Conical flashings to match roof type or a pourable type roof penetration seal system or the SnapNrack OmniShield™ Flashing.

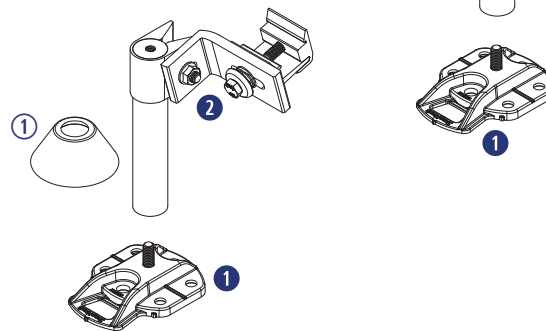

Optional Materials

- ① (2) Rubber Rain Collar (not required when sealing roof attachment with pourable roof sealant)

⚙️ Application Note:

Install on flat roof, composition shingle roof, or tile roofs when additional tilt of solar array is required.

SnapNrack Fixed Tilt Kits may be installed as deck mounted systems when incorporated with the SnapNrack OmniShield™ roof sealing component (see Installation Sequence #'s 8-13). All other roof sealing methods using the OmniBase™ will require mounting to the roof structure.

⚙️ Note:

5° - 30° is the approximate tilt angle relative to the roof surface, and is dependent on front to back standoff spacing and module orientation. Approximate tilt angles (all arrangements are based on the requirement for the front leg to be limited to the 5 1/2" or 10" Standoff Shaft): See Tilt Angle Table to right.

Installation Parameters:

- Maximum tilt angle relative to horizontal = 30° (+/- 2°)
- Module tilt to be in the same azimuth direction as roof they are to be mounted on
- Exception: Flat roofs (defined as having a slope of less than 7°)
- Maximum roof slope = 23°

Ultra Rail - Tilt Angle Table

5 deg. - 30 Degree Fixed Tilt Kits - Standoffs with Ultra Rail Tilt Clamps

		Tilt Angle (nominal)				
		Landscape				
Front to back attachment spacing	5-1/2" & 10" Standoffs	5-1/2" & 14" Standoffs	5-1/2" & 23" Standoffs	10" & 14" Standoffs	10" & 23" Standoffs	
	16"	16°	28°	N/A	14°	N/A
24"	10°	20°	N/A	9°	28°	
32"	8°	15°	28°	7°	22°	
48"	N/A	N/A	N/A	N/A	N/A	

		Portrait				
Front to back attachment spacing	5-1/2" & 10" Standoffs	5-1/2" & 14" Standoffs	5-1/2" & 23" Standoffs	10" & 14" Standoffs	10" & 23" Standoffs	
	16"	N/A	N/A	N/A	N/A	N/A
24"	N/A	N/A	N/A	N/A	N/A	
32"	8°	15°	28°	7°	22°	
48"	5°	10°	20°	5°	15°	

Notes:

1. Table is based on 60 cell modules
2. Table assumes mounting zone on portrait modules not exceeding 25% of module length
3. Maximum tilt angle allowed = 30° relative to horizontal

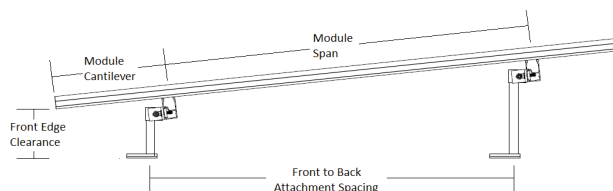

INSTALLATION INSTRUCTIONS

Installation Sequence #'s 3 through 5 pertain to installations with cone type flashings at roof. See Installation Sequence #'s 6 through 7 for installations with pourable type roof penetration seal systems and Installation Sequence #'s 8 through 13 for installations with SnapNrack OmniShield™ Flashing.

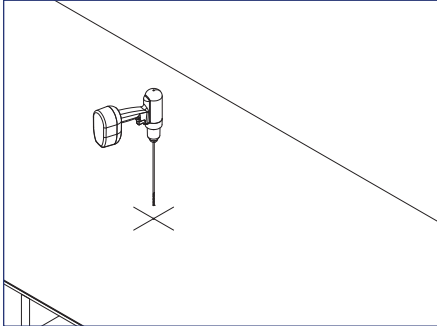

1) If required for rafter/truss applications; using roof attachment locations drawn on roof during system layout, drill pilot hole(s) into roof framing member.

Install Note:

Ensure the lag or self-drilling screws are installed in a solid portion of the roof framing member. If roof framing member is not found, seal the pilot hole immediately with proper roof sealant.

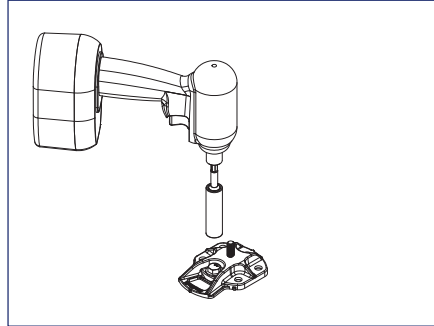

2) Apply roofing sealant to underside of OmniBase™ & in pilot hole(s). Attach Base to roof with the appropriate fastener/s based on application from the list below:

- **Standard wood rafter:** (1) 5/16" S.S. lag screw with minimum 2.5" embedment (Attachment Detail SNR-DC-01249)
- **Flat wood rafter or purlin:** (2) S.S. 5/16" lag screws with minimum 1.5" embedment (Attachment Detail SNR-DC-01250)
- **Wood I-Joist:** (2) S.S. 1/4" lag screws, choose length for proper embedment (Attachment Detail SNR-DC-01251)
- **Steel Purlin:** (2) #14 S.S. self-tapping steel fasteners, choose length for proper embedment (Attachment Detail SNR-DC-01252)
- **Concrete:** (1) 3/8" Wedge Anchor or equivalent, (2) 1/4" Wedge Anchor or equivalent, choose length for proper embedment (Attachment Detail SNR-DC-01253)
- **Standard 1/2" Roof Sheathing:** (6) #14 S.S. wood screws, choose length for proper embedment (Attachment Detail SNR-DC-01254)

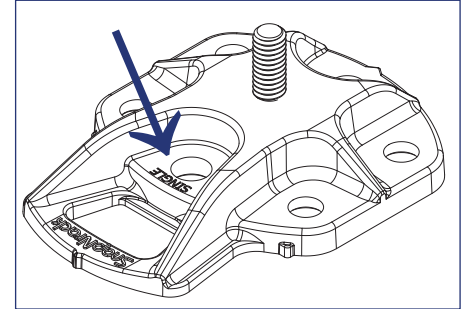

Install Note:

When attaching OmniBase™ with a single fastener, use hole labeled "Single".

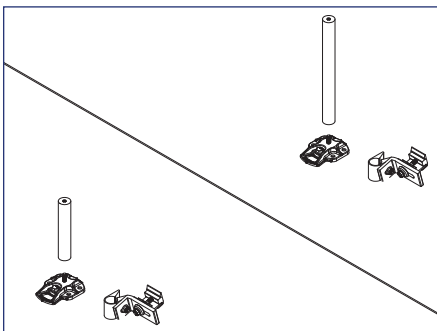

3) **Cone Type Flashings:** Install Standoff shaft onto base.

Install Note:

Standoff shafts need to be tightened to base using channel lock pliers.

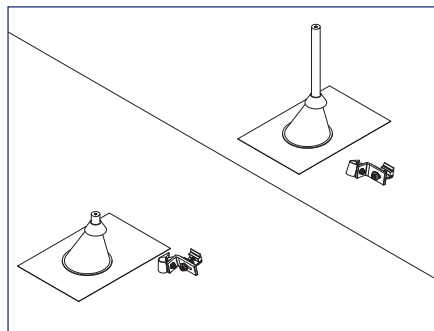

4) **Cone Type Flashings:** Install appropriate roof flashing over Standoff Shaft and seal to roof surface per roofing standards and best practices. Install Rubber Rain Collar over the Standoff Shaft.

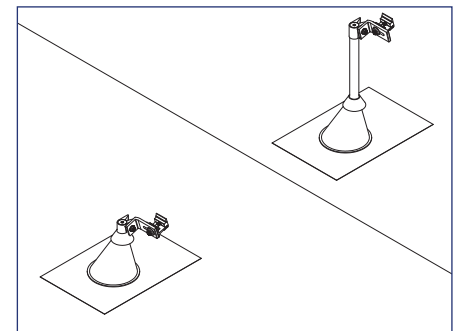

5) **Cone Type Flashings:** Install SnapNrack Ultra Rail Tilt Clamp assemblies on to Standoff Shafts.

Best Practice:

Set the Standoff Clamp assemblies approximately 1/2" below top of Standoff Shaft to accommodate final leveling adjustments.

INSTALLATION INSTRUCTIONS

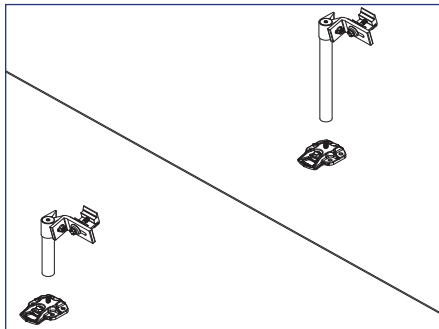

6) Pourable Type Roof Penetration Seal System: With Ultra Rail Tilt Clamp Assembly on the Standoff Shaft, install Standoff shaft onto base.

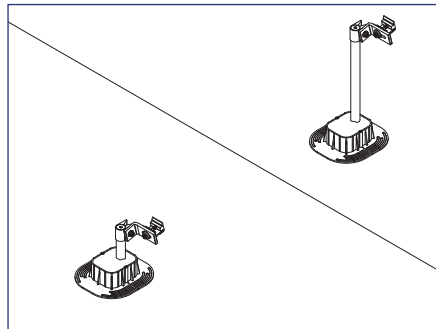

7) Pourable Type Roof Penetration Seal System: Seal roof penetrations at bases by placing curb around Base then applying pourable sealant material.

Install Note:

Standoff shafts need to be tightened to base using channel lock pliers.

Best Practice:

Set the Standoff Clamp assemblies approximately 1/2" below top of Standoff Shaft to accommodate final leveling adjustments.

Skip to installation sequence #14.

Install Note:

Follow manufacturer's instructions closely when applying this type of roof sealing system.

Install Note:

Prior to applying roof sealant on OmniShield™, verify that the sealant is compatible with the roof membrane that the OmniShield™ is being installed on.

INSTALLATION INSTRUCTIONS - OMNISHIELD™ FLASHING

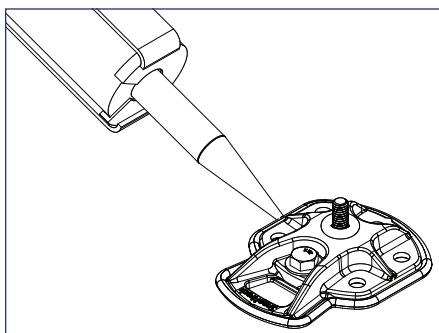

8) Apply a 1/4" bead of ChemLink M-1 roofing sealant to base of 5/16" threaded stud & to the entire perimeter of OmniBase™. Clean all smooth substrates with isopropyl or denatured alcohol a minimum of 2" all around OmniBase™. Brush away all gravel or loose granules to the same distance.

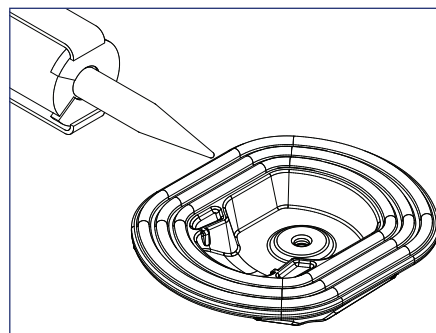

9) Apply a 1/4" bead of ChemLink M-1 roof sealant into all 3 of the grooves on the underside of OmniShield™. Sealant should be applied as raised beads approximately 1/8" higher than the underside surface of OmniShield™.

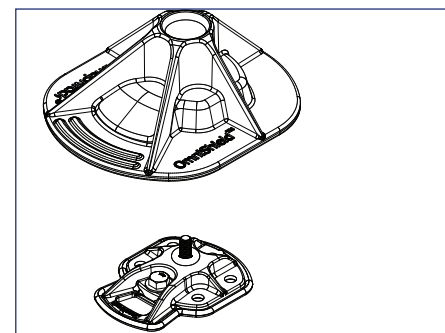

10) Install OmniShield™ on to roof over the OmniBase™, pressing firmly onto roof until sealant can be seen around the base of the OmniShield™.

Install Note:

If roof sealant is not visible around perimeter of OmniShield, lift the OmniShield off of roof, apply more sealant then reapply to roof.

INSTALLATION INSTRUCTIONS - OMNISHIELD™ FLASHING

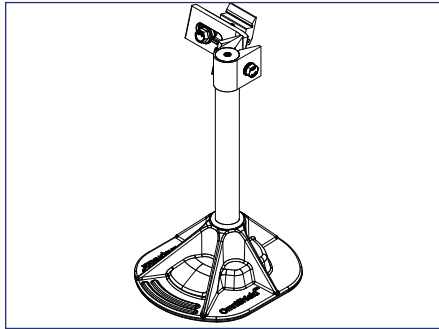

11) Install Tilt Standoff through the opening in the OmniShield™ and thread on to the 5/16" stud on the OmniBase™.

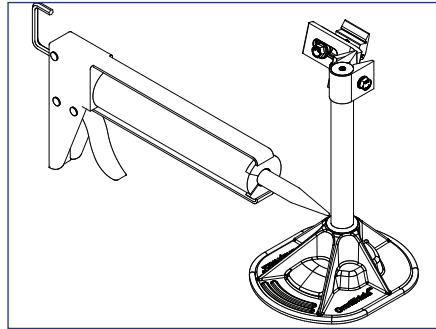

12) Apply a bead of roof sealant around the top opening of the OmniShield™ at Standoff penetration.

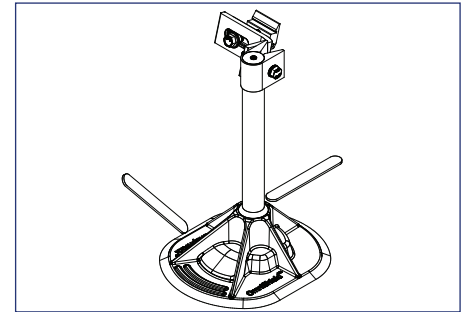

13) Smooth out the excess roof sealant at the base of the OmniShield™ and at the top opening.

Install Note:

Standoff shafts need to be tightened to base using channel lock pliers

Best Practice

Set the Standoff Clamp assemblies approximately 1/2" below top of Standoff Shaft to accommodate final leveling adjustments.

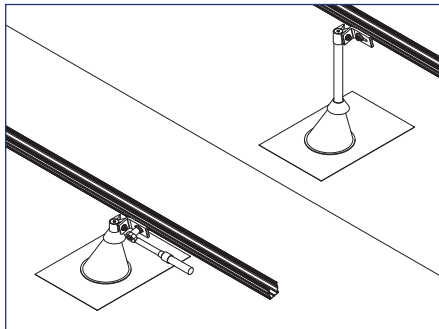

14) Set rails into the Ultra Rail Mounting Hardware on front and rear mounts then tighten the Ultra Rail Mounting Hardware to 12 ft-lbs. Connect multiple lengths of rail using the Ultra Rail Splice (see "UR-40 or UR-60 Rail Splice" sections of manual)

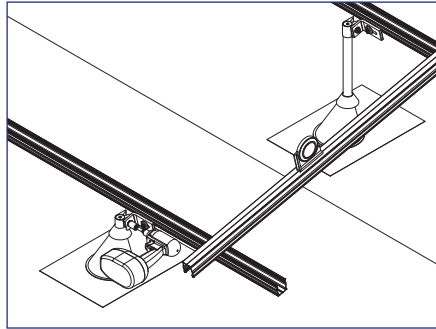

15) Set all Ultra Rail Mount angles to desired tilt angle using an Inclinometer tool or other pitch measuring device. Tighten bolts to 10+ ft-lbs.

Best Practice:

Verify that tilt angles for both front and rear rails are in alignment and flush with each other by laying a section of rail (tilt setting rail) across both rails simulating an installed module.

Installing and Leveling Rails

Required Tools

- Level
- String Line or Spare Rail
- Pitch Meter
- Torque Wrench
- Socket Wrench
- 1/2" Socket

Materials Included - Installing and Leveling Rails

- 1 SnapNrack Ultra Rail (UR-40 or UR-60)
- 2 SnapNrack Ultra Rail Splice (UR-40 or UR-60)
- 3 Pre-Installed SnapNrack Roof Attachments
(L Foot Mount, Tile Replacement, etc.)

Other Materials Required - *Not Shown*

- 1 SnapNrack Ultra Rail Leveling Spacer

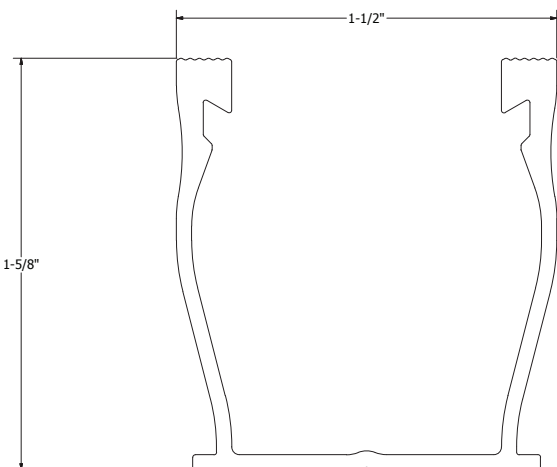
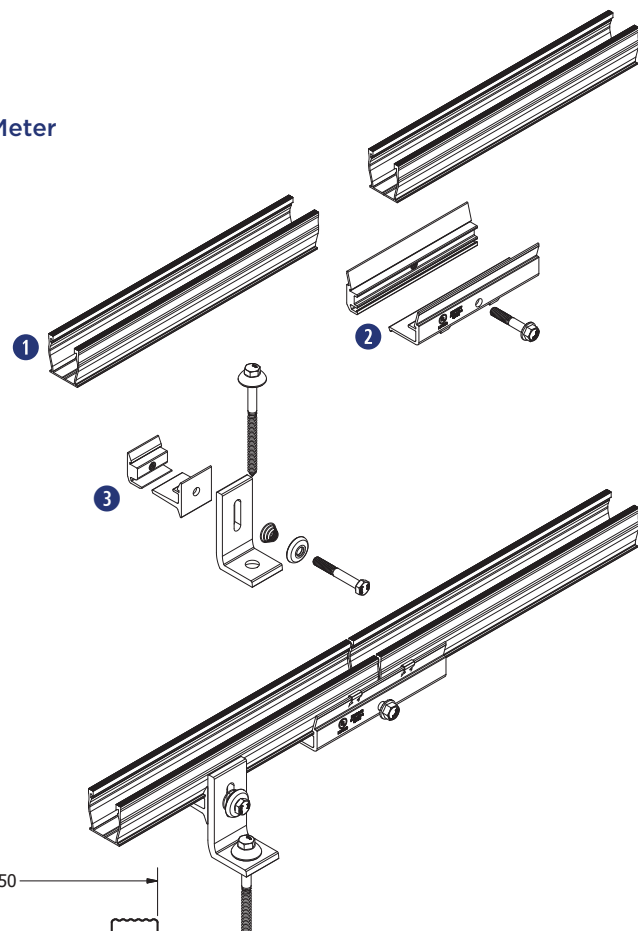

UR-40 Rail Profile

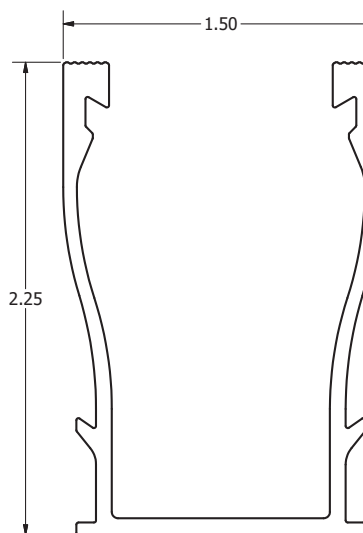

UR-60 Rail Profile

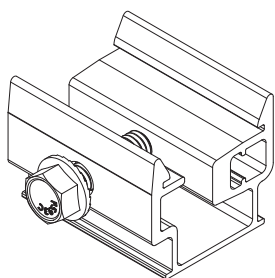

Ultra Rail Leveling Spacer

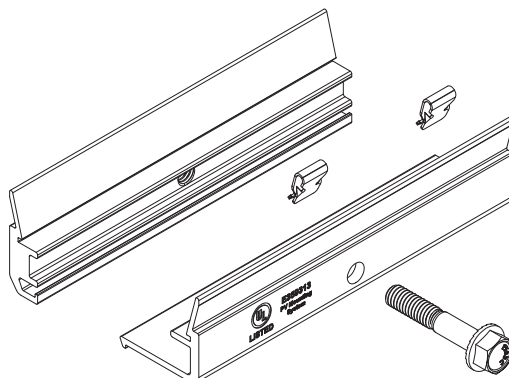

UR-40 Rail Splice

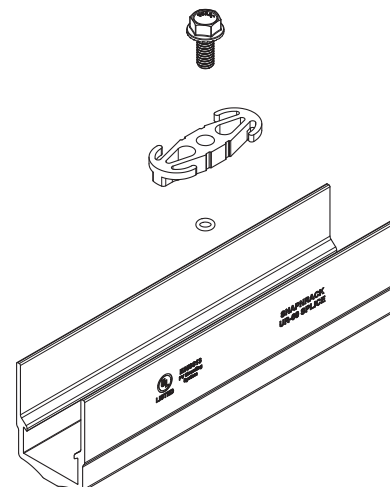

UR-60 Rail Splice

INSTALLATION INSTRUCTIONS

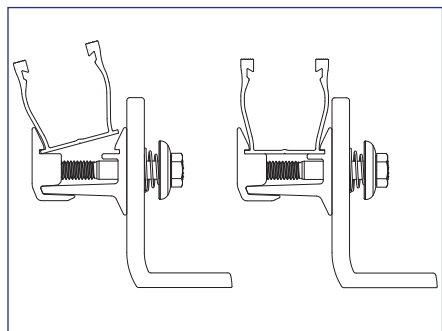

1) Set rails into the attachments by dropping and snapping into the mounts. Connect multiple lengths of rail end to end using the SnapNrack Ultra Rail Splice (see “Ultra Rail Splice” section).

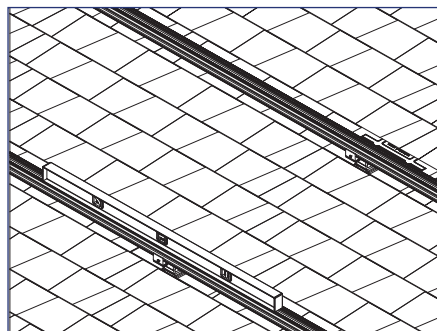

2) Level the bottom rail of the array to the roof and tighten attachment points.

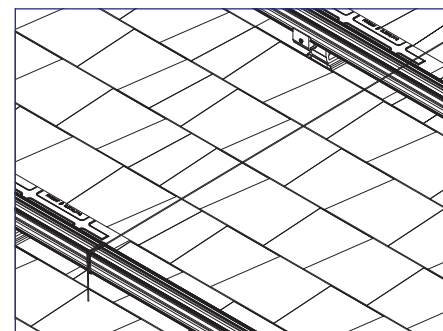

3) Run a string line or spare rail from the bottom rail to the top rail and set desired pitch of the array by adjusting the top rail, add L Foot Extension if needed.

Best Practice:

Set attachments in the middle of available leveling range to start.

Install Note:

See “Leveling Components” section for installation instruction and restrictions.

Install Note:

Slightly rocking rail into mounts can ease installation, leading first with side of rail furthest from mount.

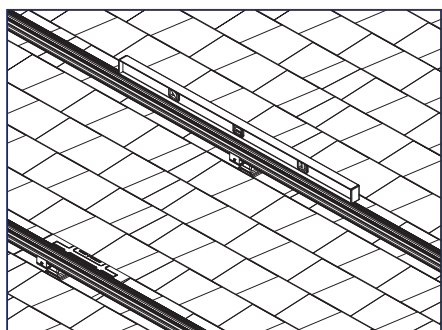

4) Level the top rail by moving the string line down the length of the rail, matching pitch over the entire length of the array.

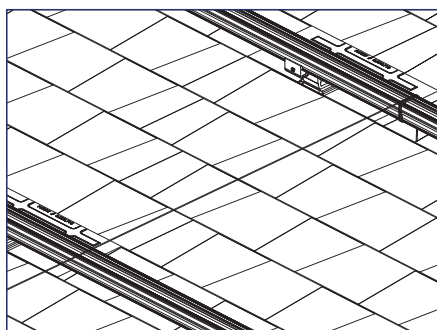

5) Level the remaining rails to the string line by working out from the middle rail, add L Foot Extensions or spacers if needed.

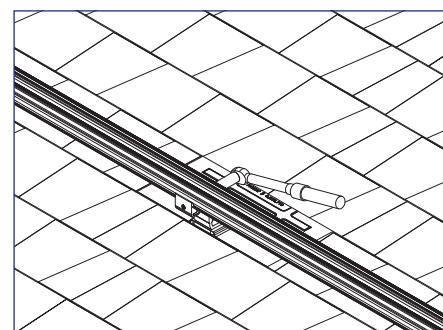

6) Tighten all racking hardware to 12 ft-lbs.

Note:

The minimum standoff height between the modules and roof is as follows:

- REC Solar, Yingli, and Suniva modules: 4.00"
- ReneSola modules: 3.93" (100 mm)
- Trina Solar modules: 4.53" (115 mm)

INSTALLATION INSTRUCTIONS

SnapNrack Ultra Rail Leveling Spacer

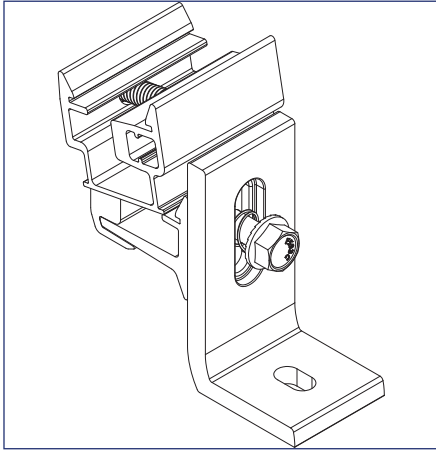

1) Snap leveling spacer into Ultra Rail mount.

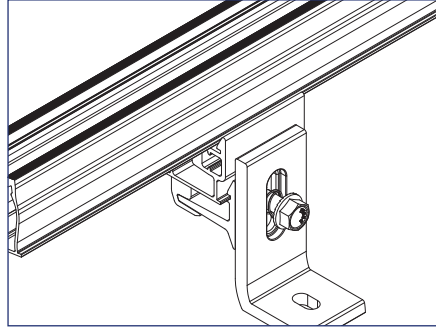

2) Snap Ultra Rail into leveling spacer.

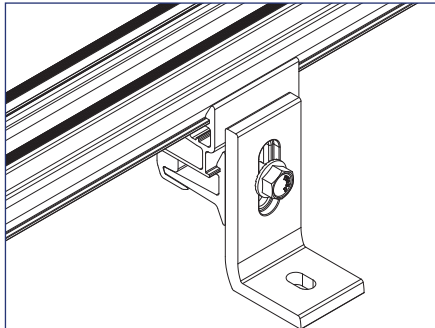

3) Finalize rail position and tighten all hardware to 12 ft-lbs.

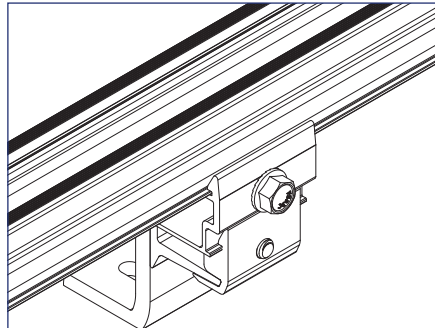

Use a single leveling spacer on no more than 30% of attachment points, and no more than two leveling spacers on more than 10%.

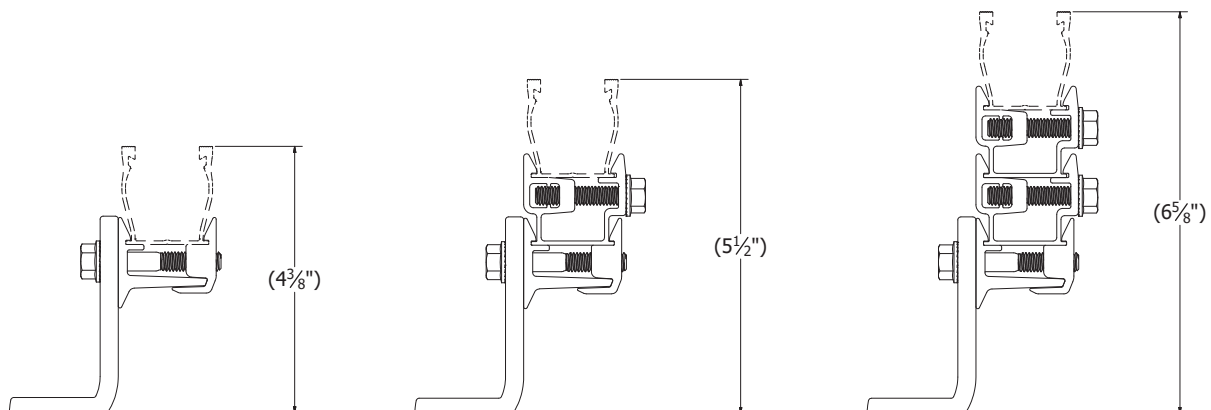

Leveling Spacer Provides Up To 2.25" of Additional Height Adjustment
(UR-60 Rail Adds $\frac{5}{8}"$ To Overall Height)

INSTALLATION INSTRUCTIONS

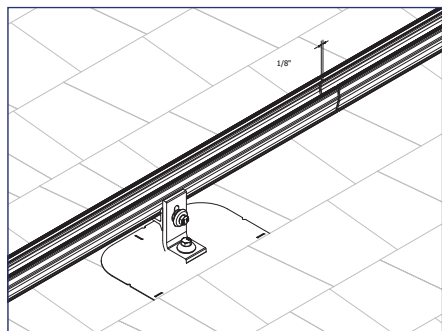

1) Align sections of rail and leave a 1/8" - 1/4" gap.

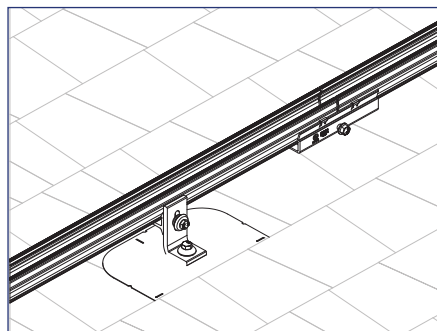

2) Install rail splice assembly onto bottom of rail, making sure both rails are seated in grooves of splice and that the splice is centered.

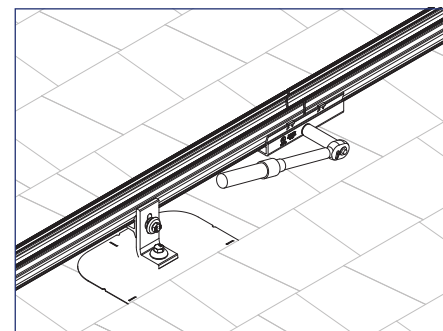

3) Tighten splice hardware to 12 ft-lbs.

⚙️ Install Note:

Leaving a gap between rails will allow for thermal expansion of rail and drainage.

Any section of rail that is spliced will need to be supported by a roof attachment on both sides. Splices are not allowed to be installed on rail cantilevers.

⚙️ Install Note:

Gap between rails must land between bonding clips on splice.

⚙️ Best Practice:

Hold sides of splice together on rails with one hand and tighten with the other.

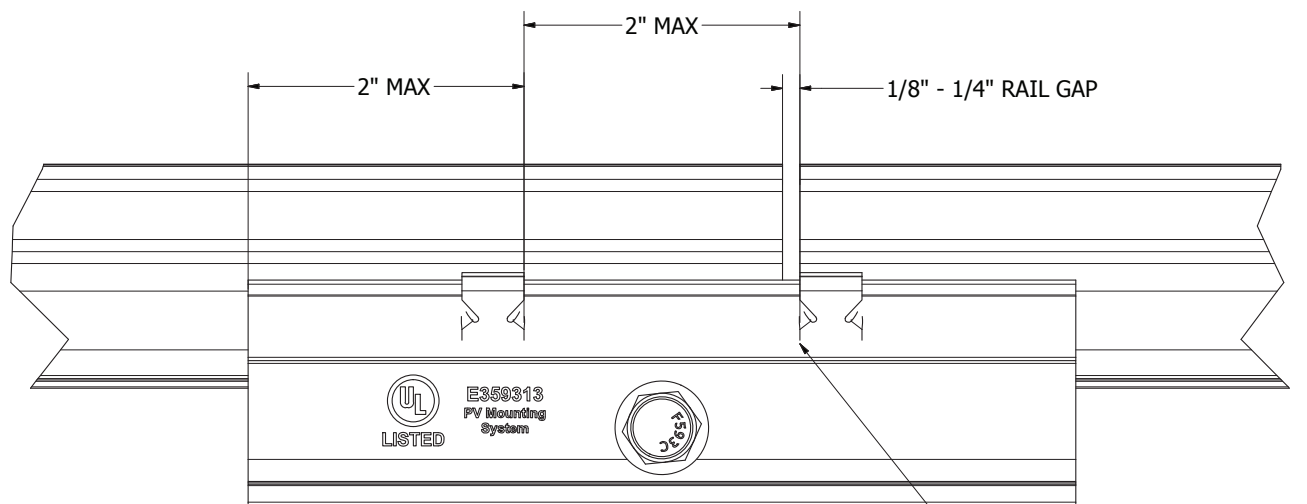

RAIL EDGE MUST NOT PASS CLIP EDGE, AS SHOWN

UR-40 Splice Installation Limitations

INSTALLATION INSTRUCTIONS

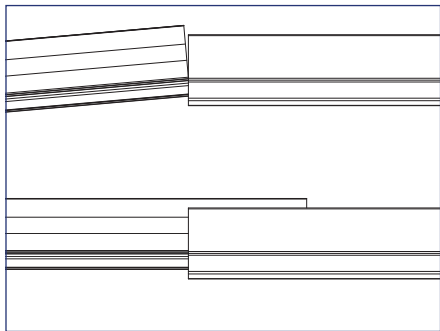

1) Slide first rail into splice, ensuring that BOTH rail flanges are engaged into lower section of splice.

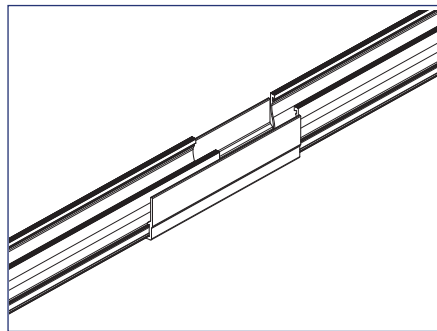

2) Slide second rail into splice, ensuring that BOTH rail flanges are engaged into lower section of splice.

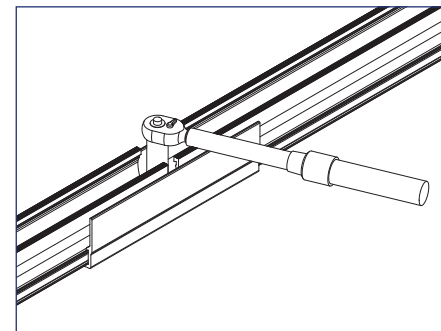

3) Tighten splice hardware to 12 ft-lbs

Best Practice:

Rocking rail in slightly from the bottom can ease install.

Install Note:

Any section of rail that is spliced will need to be supported by a roof attachment on both sides. Splices are not allowed to be installed on rail cantilevers.

Best Practice:

Rocking rail in slightly from the bottom can ease install.

Install Note:

Line up rails with notches in bridge and leave approximately 1/2" gap between rails to allow for thermal expansion of rail.

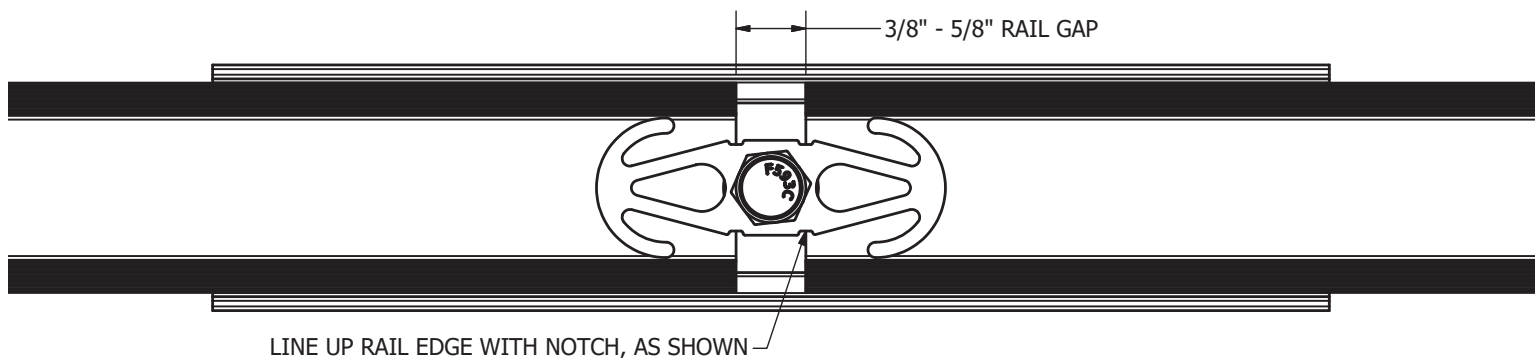

UR-60 Splice Installation Limitations

Required Tools

- Torque Wrench
- Socket Wrench
- 1/2" Socket

Materials Needed - Module Installation

- 1 Pre-Installed SnapNrack Roof Attachments
- 2 Pre-Installed SnapNrack Rails
- 3 SnapNrack Mid Clamp Assemblies
- 4 SnapNrack End Clamp Assemblies
- 5 PV Modules

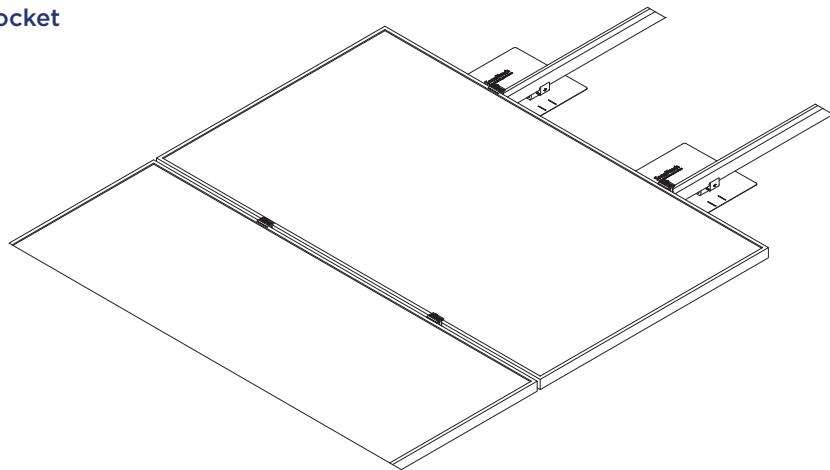

Ultra Rail Mid Clamp Assembly

- 1 (1) 5/16"-18 X 1-1/2" SS Flange Bolt
- 2 (1) SnapNrack Ultra Rail Mid Clamp Top
- 3 (1) SnapNrack Ultra Rail Mid Clamp Base
- 4 (1) SnapNrack Ultra Rail Mid Clamp Extension

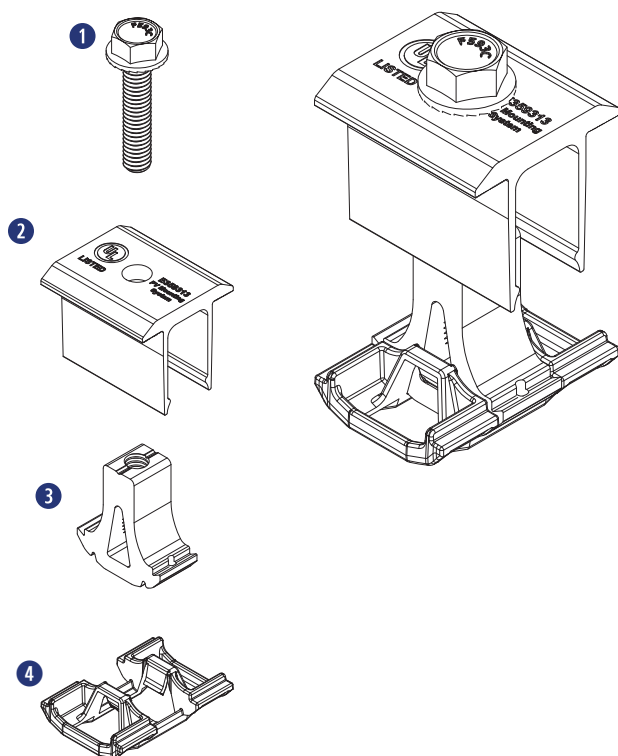

Ultra Rail End Clamp Assembly

- 1 (1) 5/16"-18 X 1-1/2" SS Flange Bolt
- 2 (1) SnapNrack Ultra Rail End Clamp Top
- 3 (1) SnapNrack Ultra Rail End Clamp Base

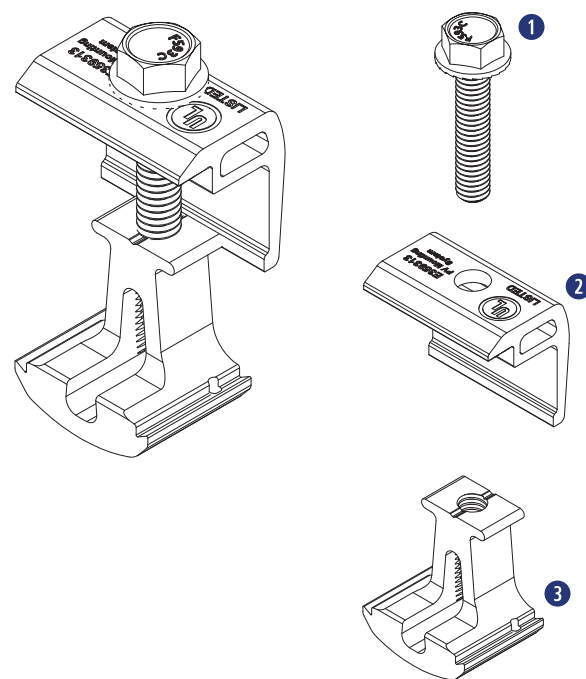

Mid Clamp Assembly

- 1 (1) 5/16"-18 SS HCS Bolt
- 2 (1) 5/16" SS Split Lock Washer
- 3 (1) SnapNrack Mid Clamp
- 4 (1) SnapNrack SS Mid Clamp Spring
- 5 (1) 5/16"-18 SnapNrack Channel Nut

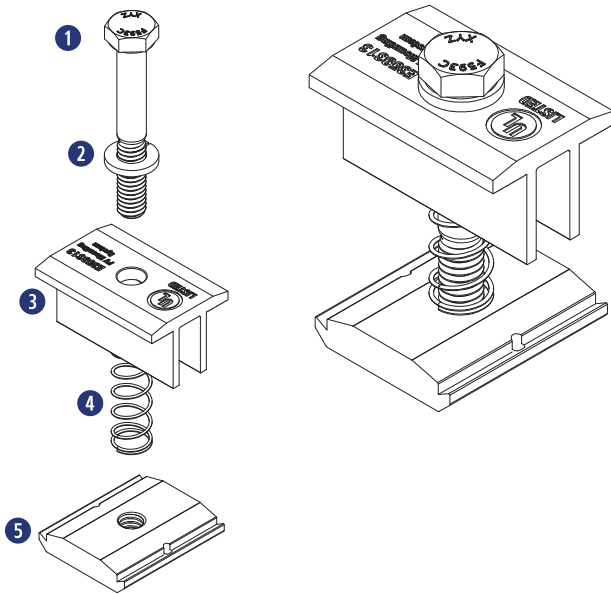

Adjustable End Clamp Assembly

- 1 (1) 5/16"-18 SS HCS Bolt
- 2 (1) 5/16" SS Split Lock Washer
- 3 (1) SnapNrack Adjustable End Clamp Top
- 4 (1) SnapNrack Adjustable End Clamp Bottom

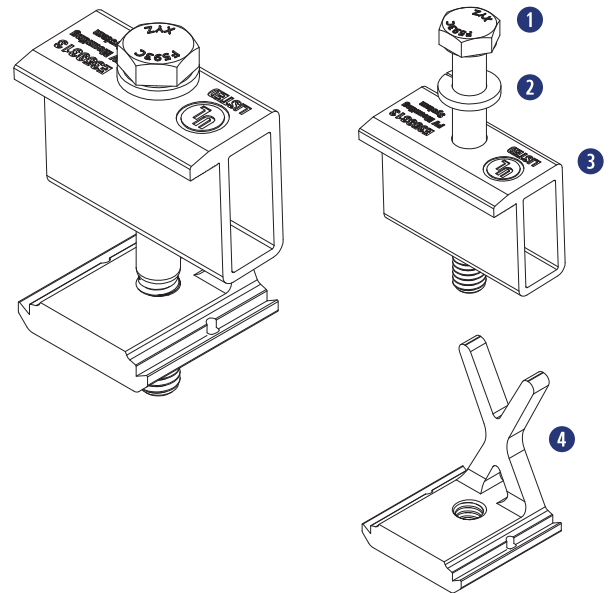

Universal End Clamp Assembly

- 1 (1) 5/16"-18 X 1-1/2" SS HCS Bolt
- 2 (1) 5/16" X 3/4" SS Flat Washer
- 3 (1) SnapNrack Universal Wedge
- 4 (1) SnapNrack Universal Wave

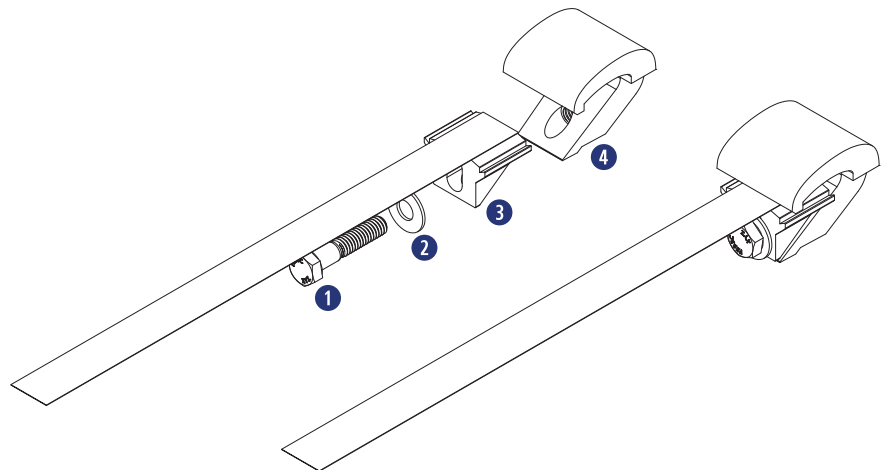

INSTALLATION INSTRUCTIONS

SnapNrack Ultra Rail Mid Clamp

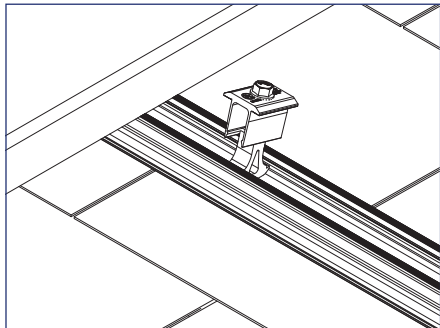

1) Snap the base into the top channel of the rail.

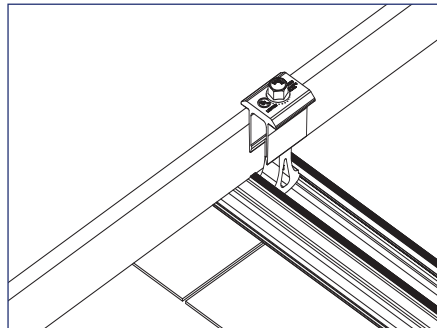

2) Slide the clamp flush to the module with the top lip of the mid clamp over the top edge of the module frame.

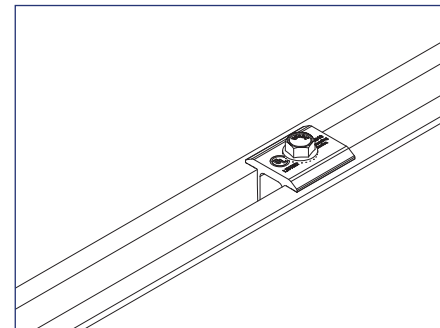

3) Place the next module flush to the other side of the mid clamp.

Best Practice:

Backing off bolt will ease installation into rail channel.

Install Note:

Module clamps cannot be installed anywhere there is a gap between rails (i.e. splice locations). Modules should be shifted slightly when this occurs.

Install Note:

Take care to avoid having wires pinched between modules and rails, as this can lead to system failure and be dangerous.

Install Note:

Ultra Rail Mid Clamps create 3/4" gap between modules.

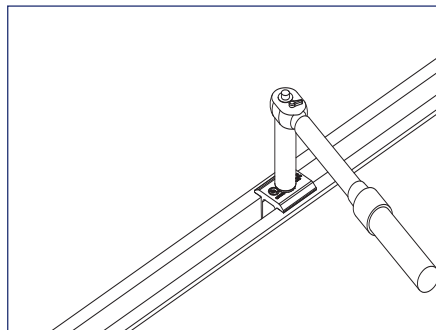

4) Tighten hardware to 16 ft-lbs.

INSTALLATION INSTRUCTIONS

SnapNrack Ultra Rail End Clamp

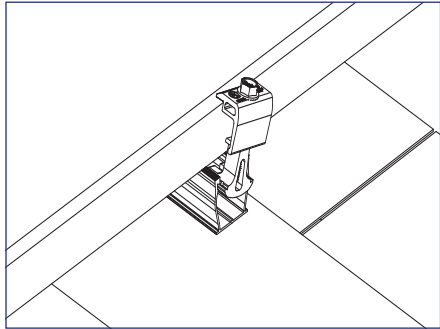

1) Snap the end clamp base into the top channel of the rail.

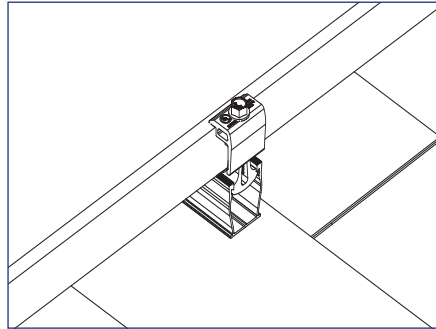

2) Slide the clamp flush to the module with the top lip of the end clamp over the top edge of the module frame.

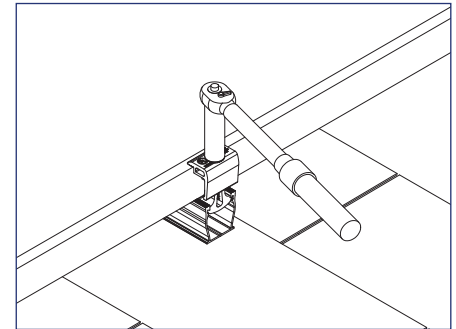

3) Tighten hardware to 16 ft-lbs.

Install Note:

Ultra Rail End Clamps require extra rail to ensure that channel nut is fully engaged.

Module clamps cannot be installed anywhere there is a gap between rails (i.e. splice locations). Modules should be shifted slightly when this occurs.

Install Note:

Take care to avoid having wires pinched between modules and rails, as this can lead to system failure and be dangerous.

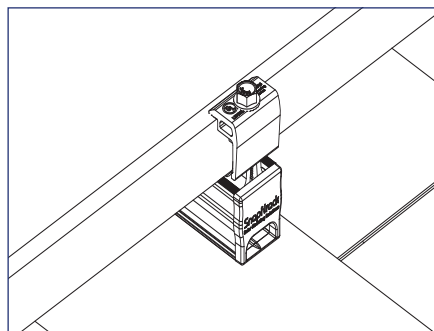

4) Install end cap to finish.

INSTALLATION INSTRUCTIONS

SnapNrack Mid Clamp

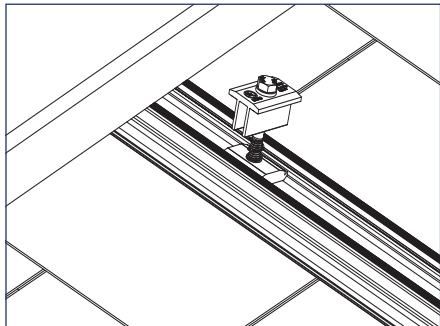

1) Snap the channel nut into the top channel of the rail.

 **Best Practice:**
Backing channel nut off bolt will ease installation into rail channel.

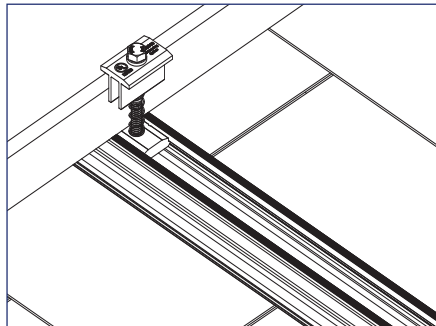

2) Slide the clamp flush to the module with the top lip of the mid clamp over the top edge of the module frame.

 **Install Note:**
Take care to avoid having wires pinched between modules and rails, as this can lead to system failure and be dangerous.

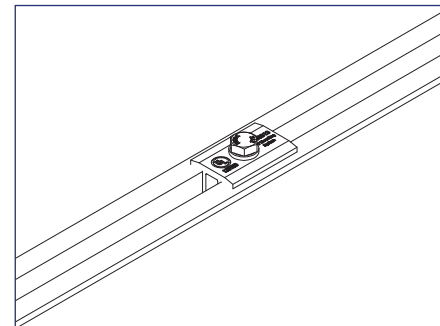

3) Place the next module flush to the other side of the mid clamp.

 **Install Note:**
Mid clamps create 1/2" gap between modules.

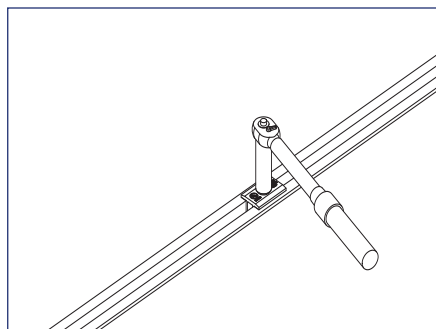

4) Tighten hardware to 10 ft-lbs.

 **Install Note:**
Mid clamps are Listed with and without springs.

INSTALLATION INSTRUCTIONS

SnapNrack Adjustable End Clamp

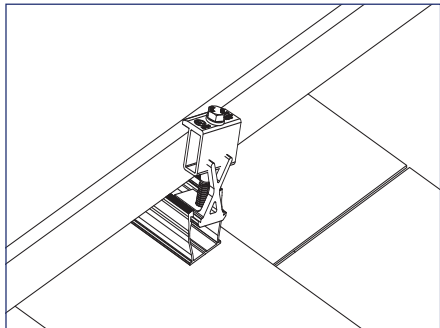

1) Snap the channel nut into the top channel of the rail.



Install Note:

Adjustable End Clamps require extra rail to ensure that channel nut is fully engaged.

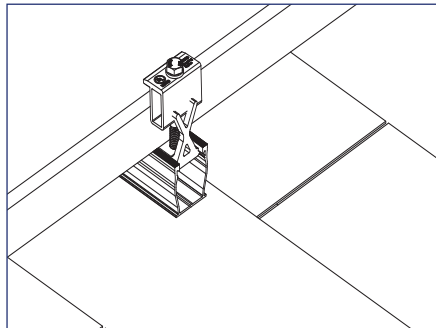

2) Slide the clamp flush to the module with the top lip of the end clamp over the top edge of the module frame.



Install Note:

Take care to avoid having wires pinched between modules and rails, as this can lead to system failure and be dangerous.

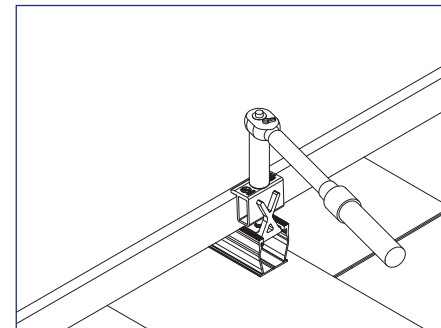

3) Tighten hardware to 10 ft-lbs.

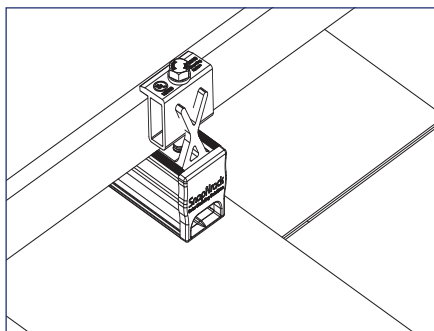

4) Install end cap to finish.

INSTALLATION INSTRUCTIONS

SnapNrack Universal End Clamp

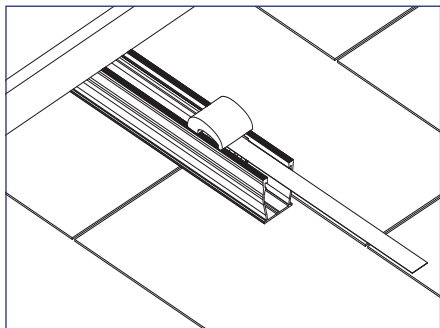

1) Slide the preassembled Universal End Clamp (UEC) into the end of the rail.

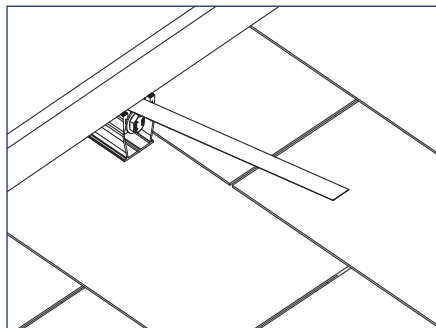

2) Lift the module and slide the clamp far enough under the module to pass the lip of the bottom edge of the module frame.



Install Note:

Take care to avoid having wires pinched between modules and rails, as this can lead to system failure and be dangerous.

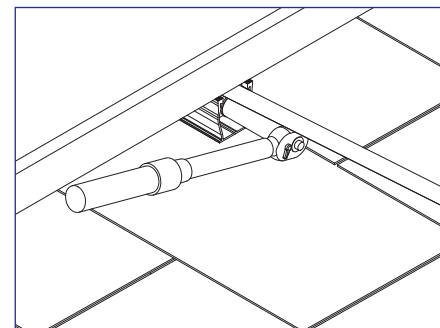

3) Use the pull tab to hold the UEC taut towards the end of the rail and tighten hardware to 10 ft-lbs.



Install Note:

Rail can be cut flush to the module when using UEC.

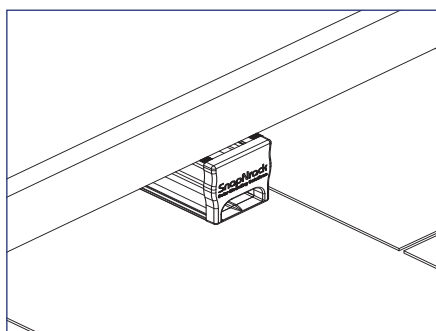

4) Install end cap to finish.



Install Note:

Modules need to be grounded separately when Universal End Clamps are the only type of clamp attaching a module.

Required Tools

- Reciprocating Saw or Portable Band Saw

Materials Included - Rail Cutting Tool and Rail End Cap

- ① (1) SnapNrack Rail Cutting Tool
- ② (1) SnapNrack Ultra Rail End Cap (UR-40 or UR-60)

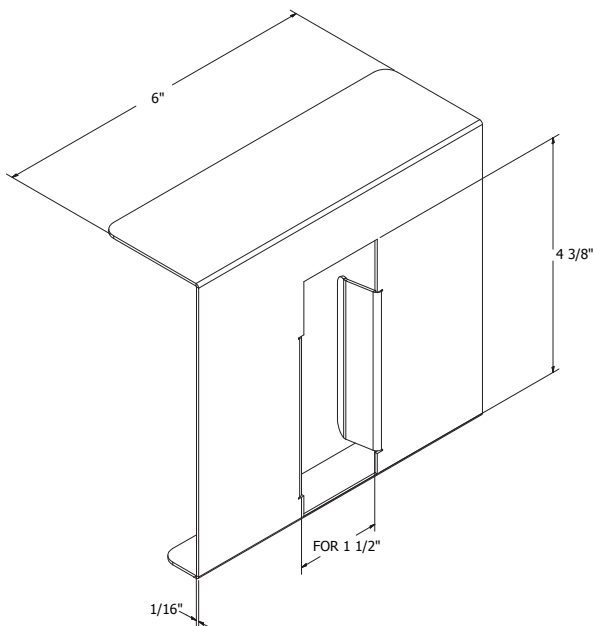
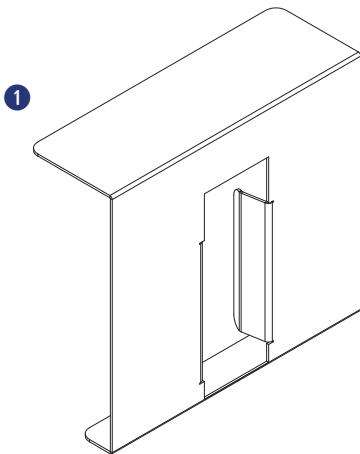

Dimensioned Rail Cutting Tool

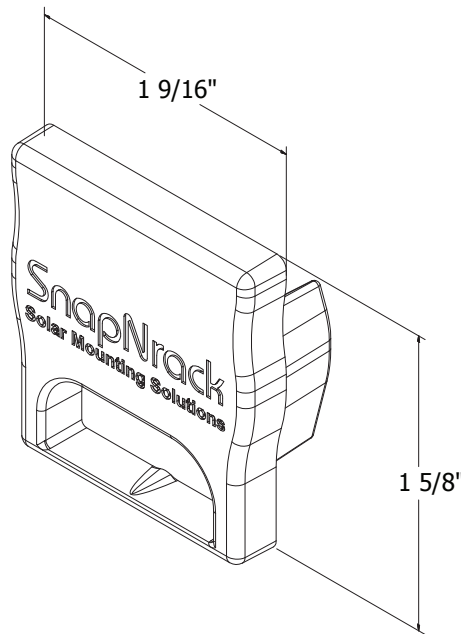

Dimensioned UR-40 Rail End Cap

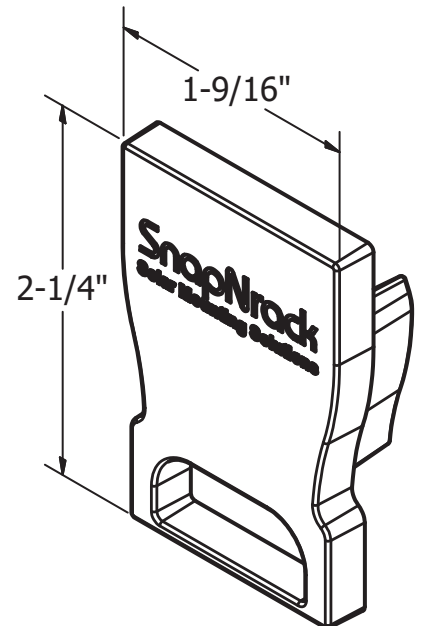

Dimensioned U-60 Rail End Cap

Application Note:

Use to cut rail flush to module frame when using Universal End Clamps (UEC).

INSTALLATION INSTRUCTIONS

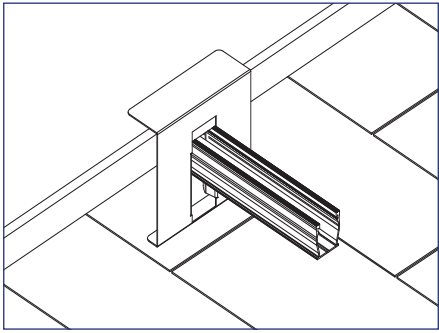

1) Slide the Rail Cutting Tool over the end of the rail and place it so that the upper lip is safely covering the edge of the module (*optional*).

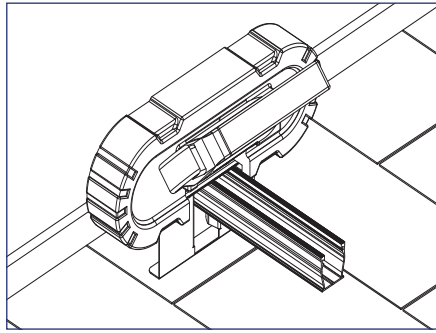

2) Use the reciprocating saw or band saw to cut off the end of the rail, then remove any sharp edges.

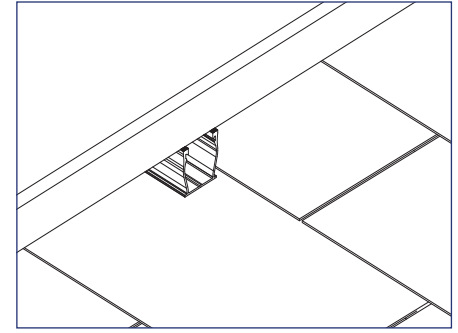

3) Remove the Cutting Tool from the rail, then remove any sharp edges.

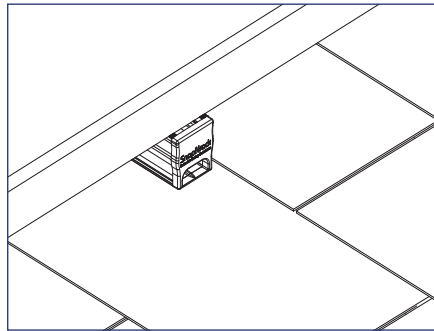

4) Insert SnapNrack Ultra Rail End Cap into the cut end of the rail to create a flush finish to the array.

Required Tools

- Reciprocating Saw or Chop Saw (Rail Cover)
- Socket Wrench (Wire Clamp)
- 1/2" Socket (Wire Clamp)

Materials Included - Rail Cover

- 1 (1) SnapNrack 48" Rail Cover

Application Note:
Install to protect any conductors that are exposed to sunlight that are not approved for use in UV light.

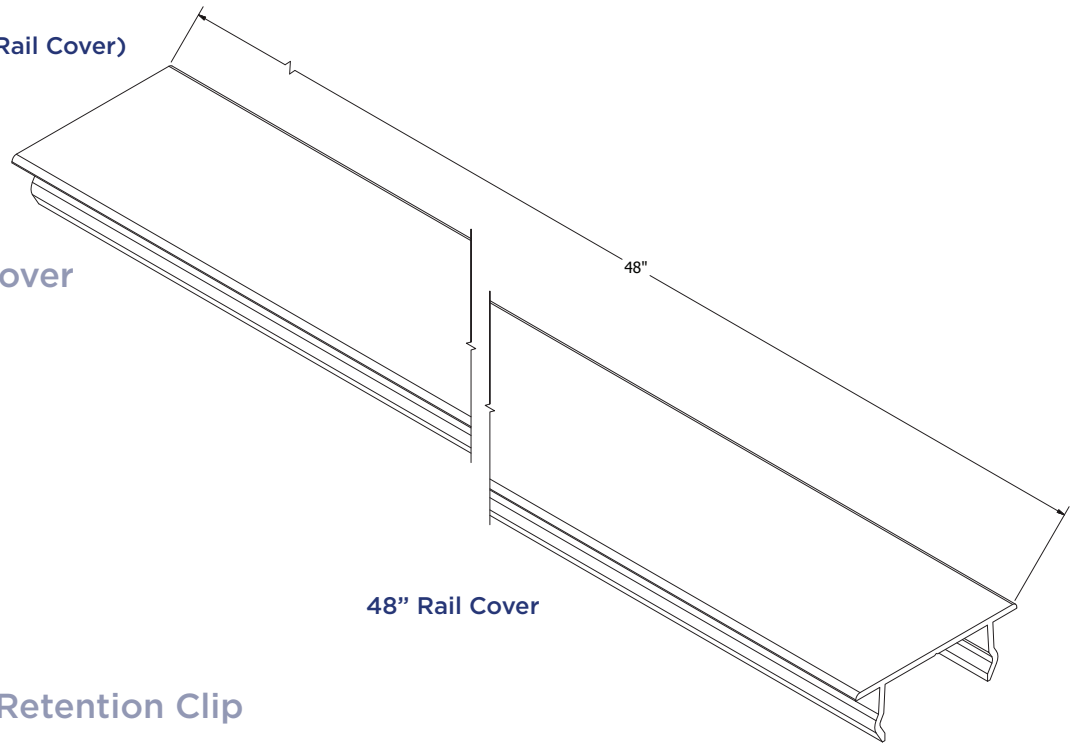

48" Rail Cover

Materials Included - Wire Retention Clip

- 1 SnapNrack Wire Retention Clip



Wire Retention Clip

Application Note:
Install as necessary to manage and safely retain conductors within SnapNrack rails.

Materials Included - Wire Clamp

- 1 (1) SnapNrack 4-Wire Clamp, Trunk Cable Clamp, or Universal Wire Clamp

Application Note:
Install as necessary to secure cables and conductors running from rail to rail, or transitioning out/in from a rail channel

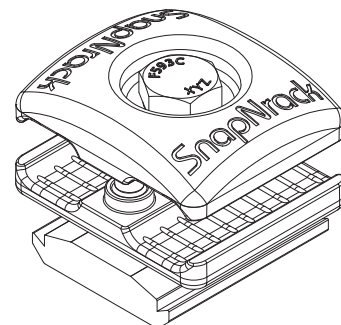

Universal Wire Clamp Assembly

INSTALLATION INSTRUCTIONS

SnapNrack 48" Rail Cover

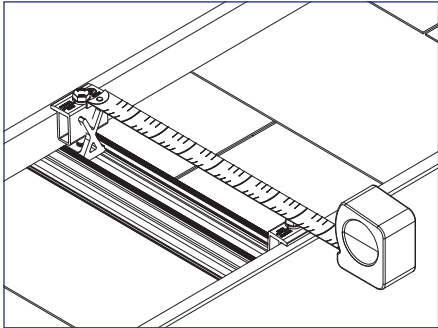

1) Measure the length of the SnapNrack 48" Rail Cover that is needed.

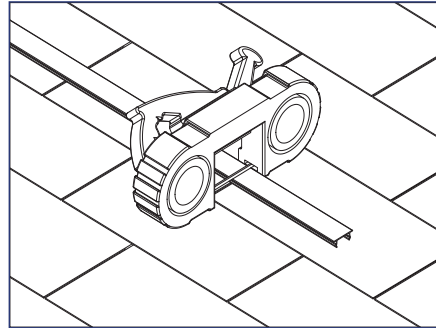

2) Cut the rail cover to length, then remove any sharp edges.

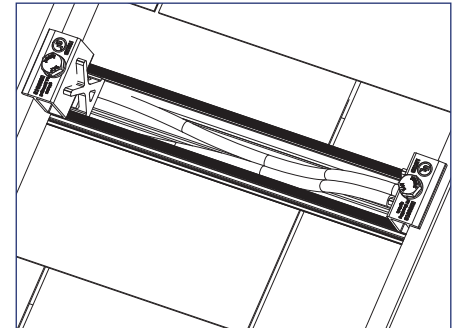

3) Place all electrical conductors in the bottom of the rail channel.

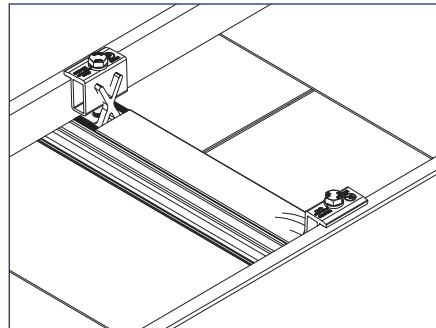

4) Snap Rail Cover into place, enclosing all conductors inside of rail channel.

Install Note:

SnapNrack Rail Cover is designed to stay in place once installed, use a flat blade screw driver if it needs to be relocated or removed.

INSTALLATION INSTRUCTIONS

SnapNrack Wire Retention Clip

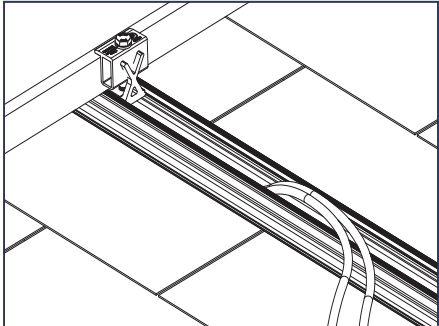

1) Place all electrical conductors in the bottom of the rail channel.

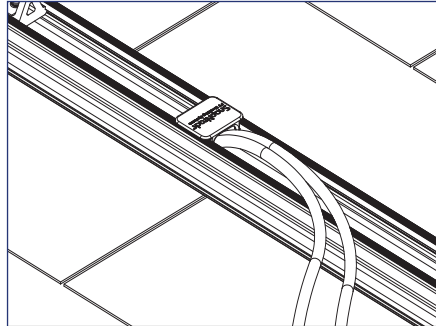

2) Install the Wire Retention Clip by snapping it into place on the rail.

SnapNrack 4-Wire, Trunk Cable, or Universal Wire Clamp

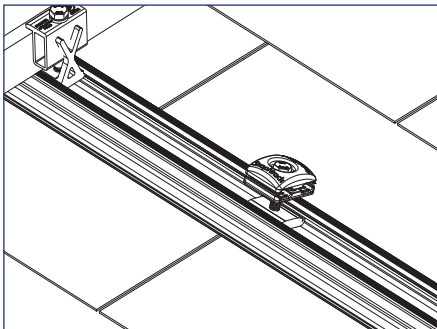

1) Snap Wire Clamp into top or side rail channel.

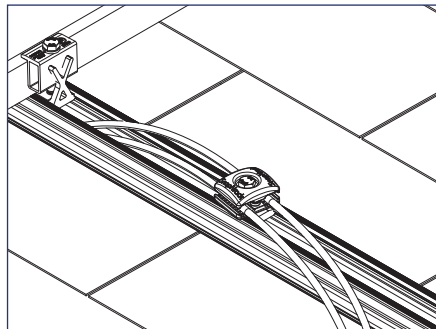

2) With Wire Clamp loose, place conductors or cables in slots.

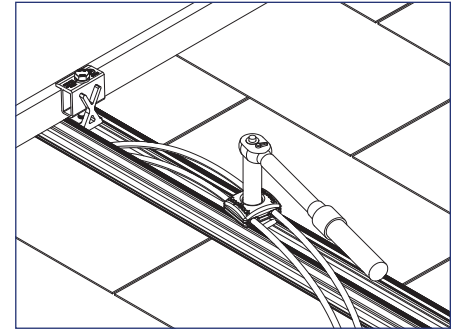

3) Tighten Wire Clamp with 1/2" socket, ensure cables and conductors are aligned in the clamp slots.

 Install Note:

Wire Clamps can be rotated and oriented in any direction.

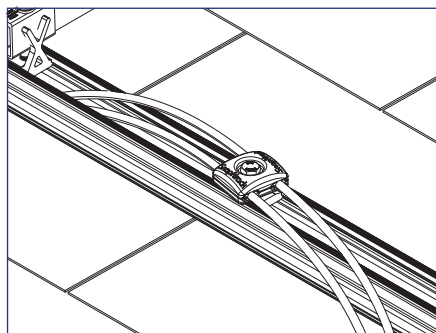

4) 4-Wire Clamp intended for PV Wire conductors, Trunk Cable Clamp intended for trunk cables, Universal Wire Clamp intended for both PV Wire conductors and AC trunk cables.

 Install Note:

Conductors of different types should be placed under separate Universal Wire Clamps.

Required Tools

- Torque Wrench
- Socket Wrench
- 1/2" Socket

Materials Included - MLPE Rail Attachment Kit

- ① (1) 5/16" X 1-1/2" X 0.125" SS Fender Washer
- ② (1) SnapNrack Channel Nut
- ③ (1) 5/16"-18 X 1-1/4" SS Flange Bolt

Other Materials Required

- ① (1) MLPE Unit

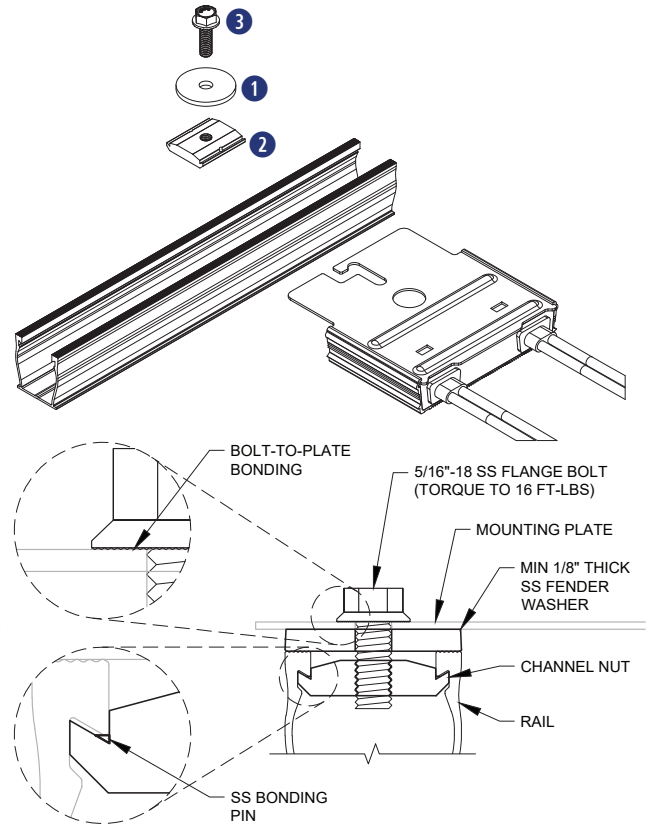
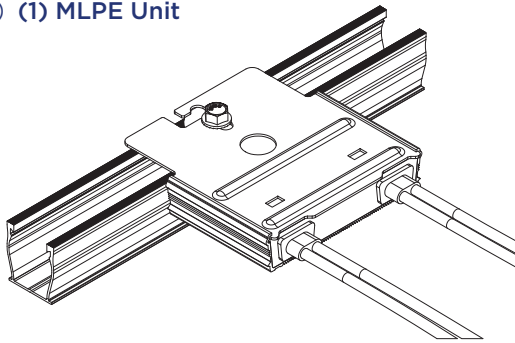

Materials Included - MLPE Frame Attachment Kit

- ① (1) SnapNrack MLPE Frame Attachment Top
- ② (1) SnapNrack MLPE Frame Attachment Bottom
- ③ (1) 5/16"-18 X 3/4" SS Flange Bolt
- ④ (1) SnapNrack Smart Clip II
- ⑤ (1) SnapNrack MLPE Frame Attachment SS Coil Spring

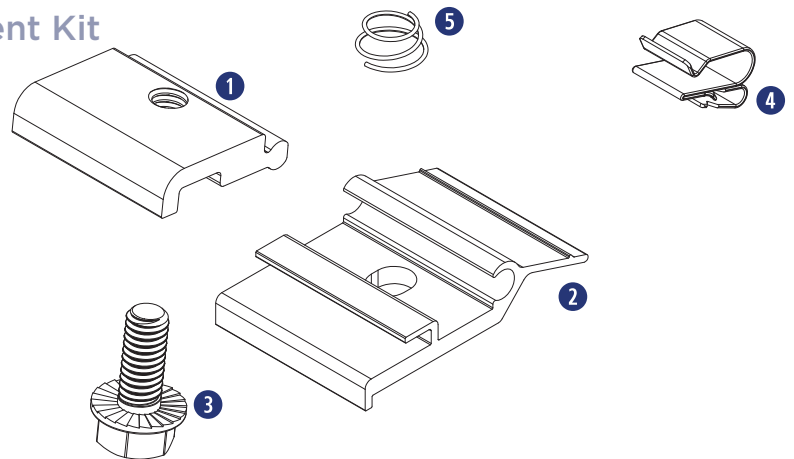

Other Materials Required

- ① (1) MLPE Unit

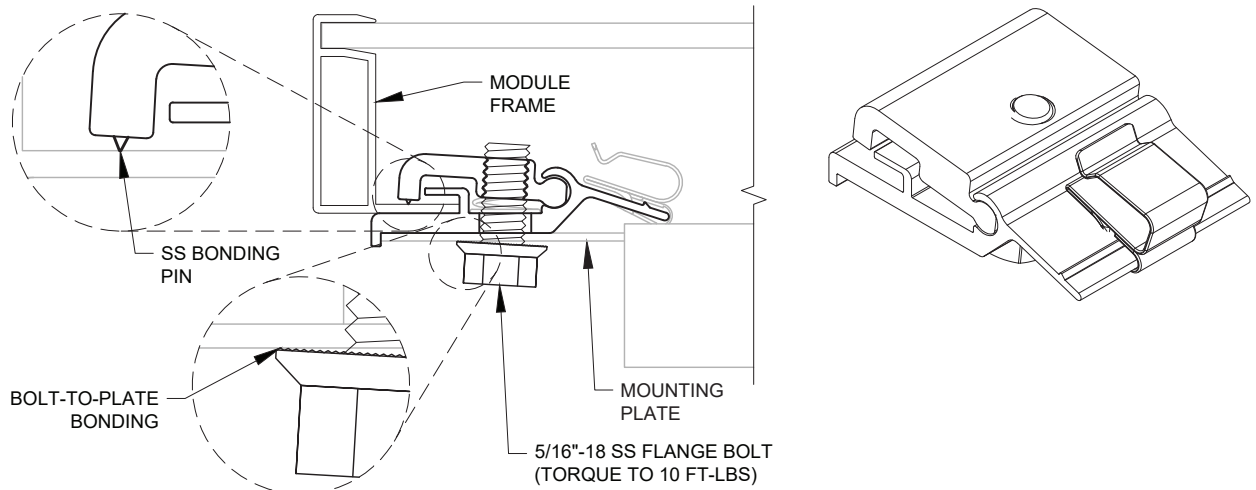

Materials Needed - SolarEdge Frame Mount

- ① (1) SolarEdge Optimizer w/ Frame-Mounted Module Add-On

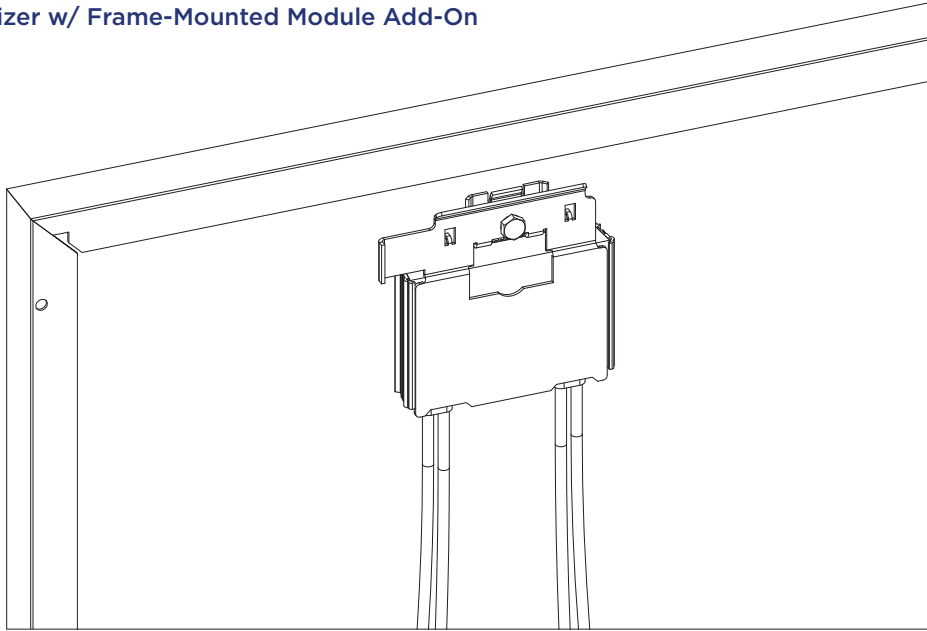

Materials Needed - Enphase Frame Mount

- ① (1) Enphase Microinverter
- ② (1) Enphase Frame Mount

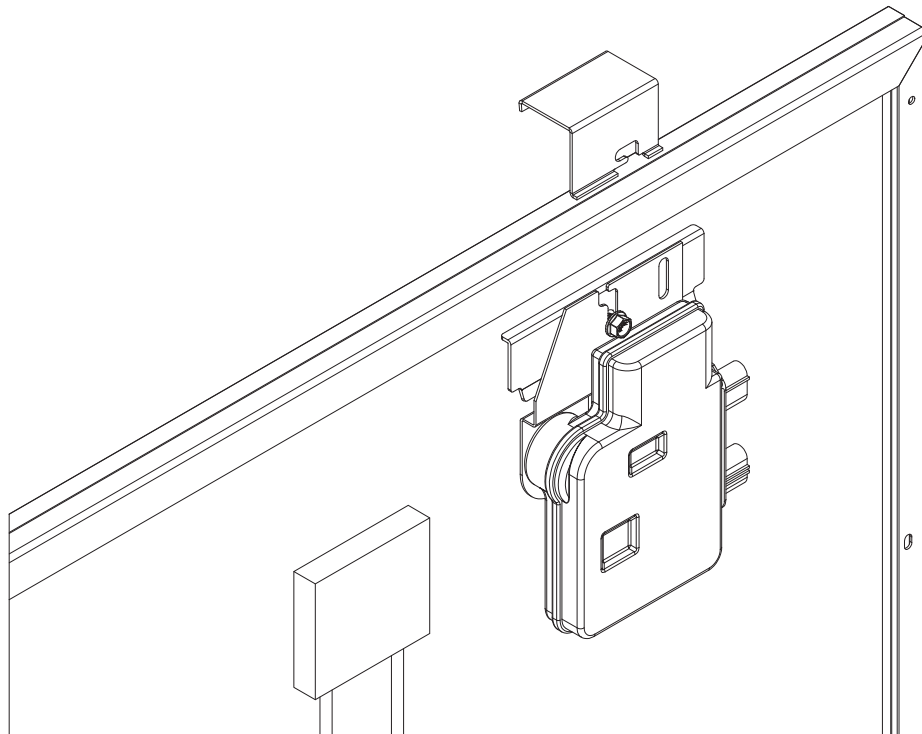

INSTALLATION INSTRUCTIONS - MLPE RAIL ATTACHMENT

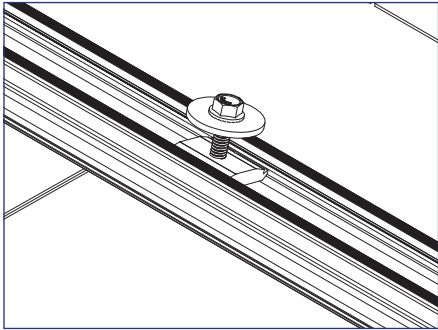

1) Snap the SnapRack MLPE Rail Attachment Kit channel nut into the desired location on the rail where the microinverter will be installed.

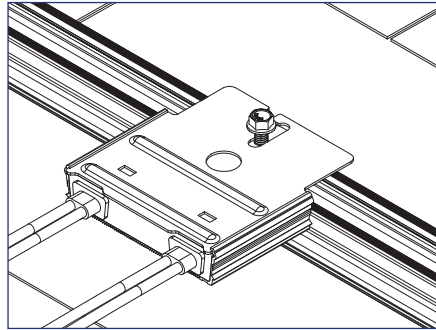

2) Install the microinverter mounting plate onto the bolt of the MLPE Rail Attachment Kit, ensuring that the large fender washer is between the rail and mounting plate.

Install Note:

Bolt and washers may need to be removed and then replaced.

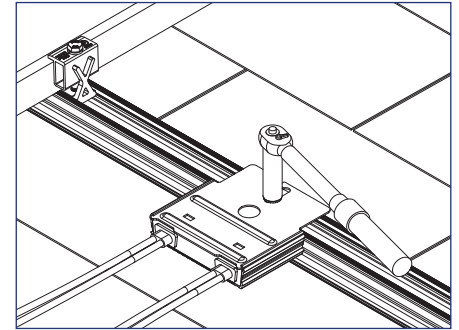

3) Tighten hardware to 10 ft-lbs.

Install Note:

MLPE Attachment Kits are approved for bolt lengths between 1" and 1-1/2" long.

INSTALLATION INSTRUCTIONS - MLPE FRAME ATTACHMENT

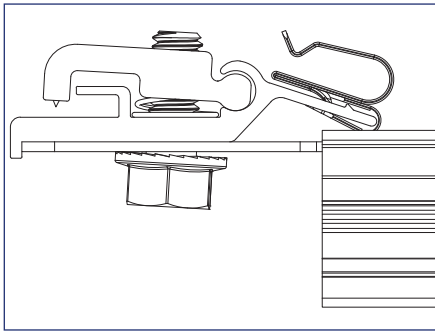

1) Slide the backplate channel of the MLPE device under the MLPE Frame Attachment Kit bolt. The MLPE mounting plate should rest against the MLPE mounting plate backstop on the MLPE Frame Attachment Kit.

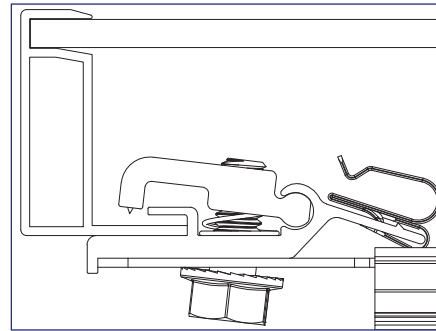

2) Position the MLPE Frame Attachment Kit on the module frame flange in a location that will not interfere with mounting system components. The module frame flange should rest against the module flange backstop on the MLPE Frame Attachment Kit.

Install Note:

Avoid blocking module frame drainage holes when installing the MLPE Frame Attachment Kit.

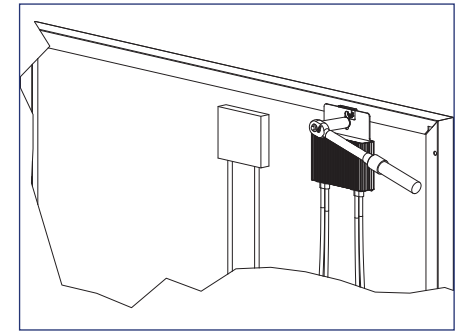

3) Tighten the mounting bolt on the MLPE Frame Attachment Kit to 10 ft-lbs.

Install Note:

The MLPE Frame Attachment Kit bonds the following components: Module Frame, MLPE backplate and Smart Clip.

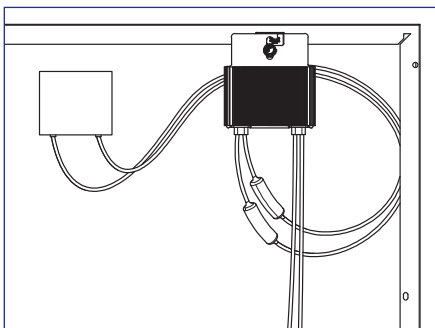

4) Connect the module leads to the input connectors on the MLPE device and manage conductors with the integrated Smart Clip.

INSTALLATION INSTRUCTIONS - SOLAREGE FRAME MOUNT

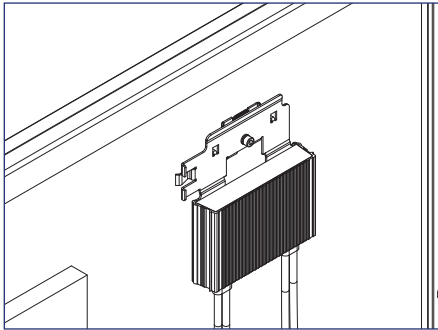

1) Locate the SolarEdge optimizer with Frame-Mounted Module Add-On at a location on the module frame that will not interfere with the SnapNrack rail.

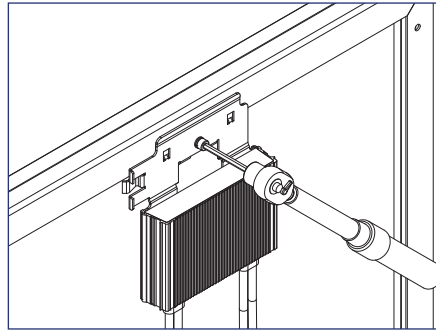

2) Install the optimizer mounting plate onto the module frame and tighten hardware to 7 ft-lbs.

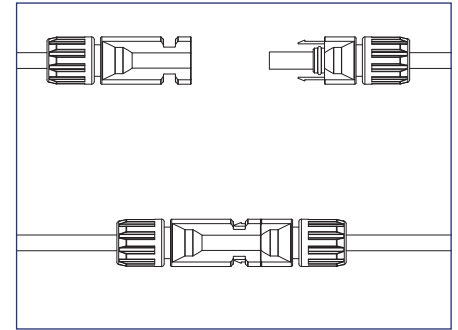

3) Connect the module leads to the input connectors on the optimizer.

Install Note:

Refer to the SolarEdge optimizer Frame-Mounted Module Add-On installation guide for additional instructions.

INSTALLATION INSTRUCTIONS - ENPHASE FRAME MOUNT

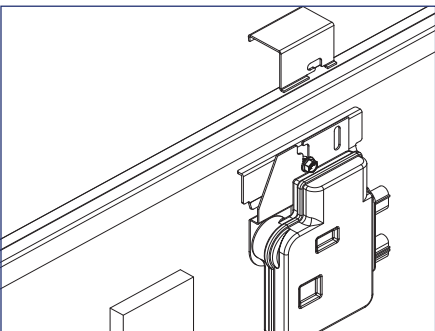

1) Locate the Enphase Frame Mount bracket clamp at a location on the module frame that will not interfere with the SnapNrack rail.

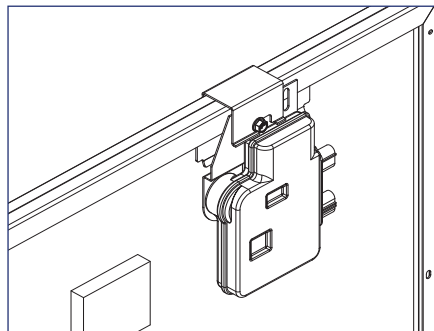

2) Slide the microinverter unit onto the bracket clamp, then move it slightly to the left.

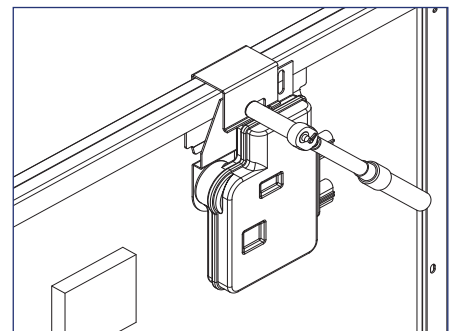

3) Tighten hardware to 13 ft-lbs

Install Note:

The microinverter mounting flange should be on the outside of the module frame.

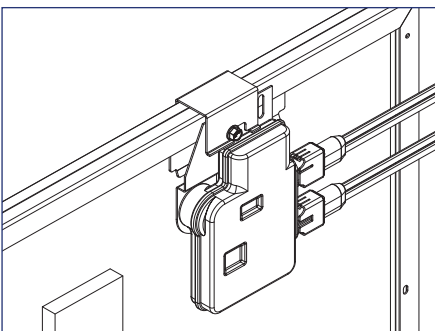

4) Connect the module leads to the microinverter DC connectors.

Install Note:

Refer to the Enphase Frame Mount installation guide for additional instructions.

System Bonding Methods

- 1 SnapNrack Ultra Rail Mid Clamp
- 2 SnapNrack Ultra Rail End Clamp
- 3 SnapNrack Mid Clamp
- 4 SnapNrack Adjustable End Clamp
- 5 SnapNrack UR-40 Rail Splice
- 6 SnapNrack UR-60 Rail Splice

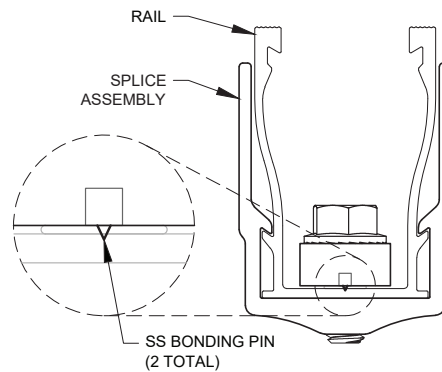
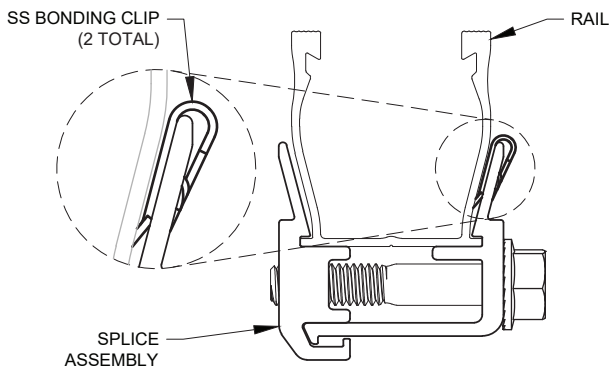
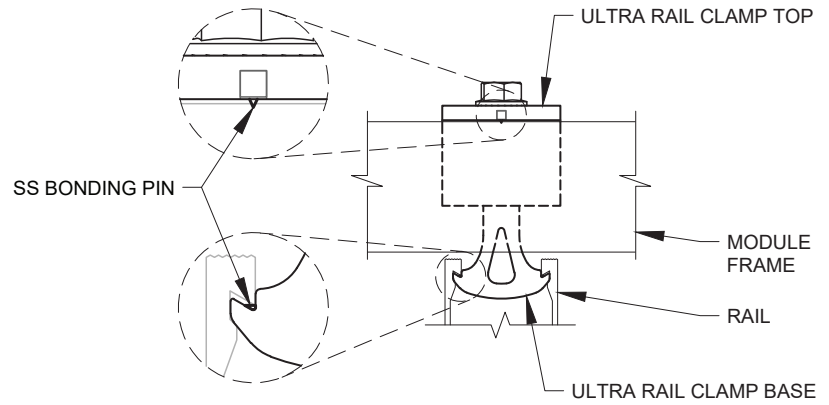

Note:
SnapNrack module clamps contain a SnapNrack Channel Nut with integral bonding clips or pins in assembly to properly bond the system (except Universal End Clamps).

Note:
SnapNrack Ultra Rail Splices contain integral bonding clips in assembly to properly bond the system.

SnapNrack Ground Lug Assembly

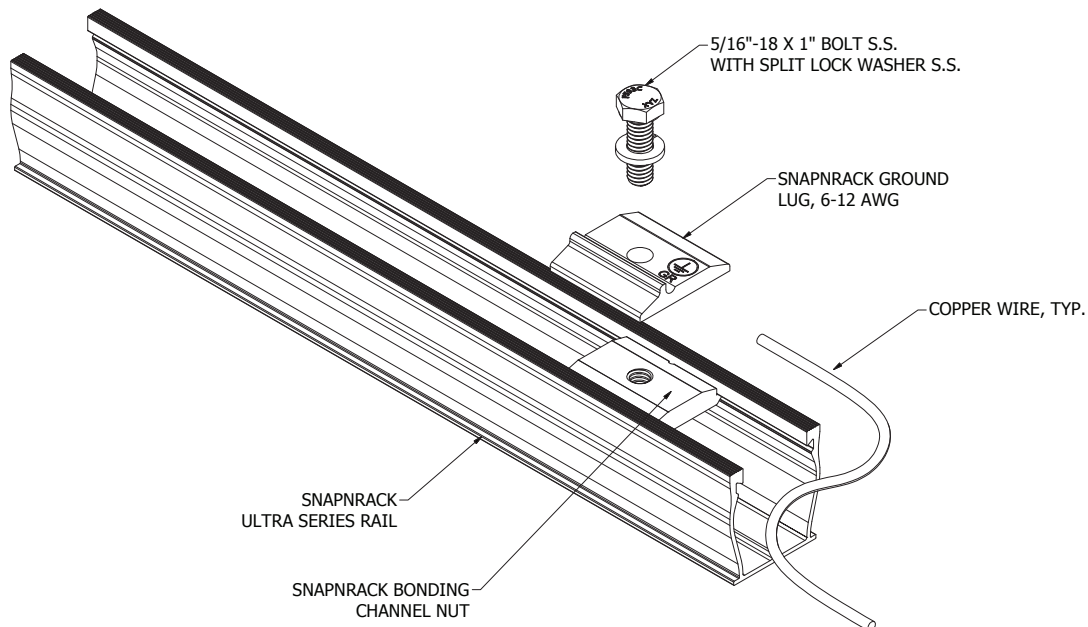



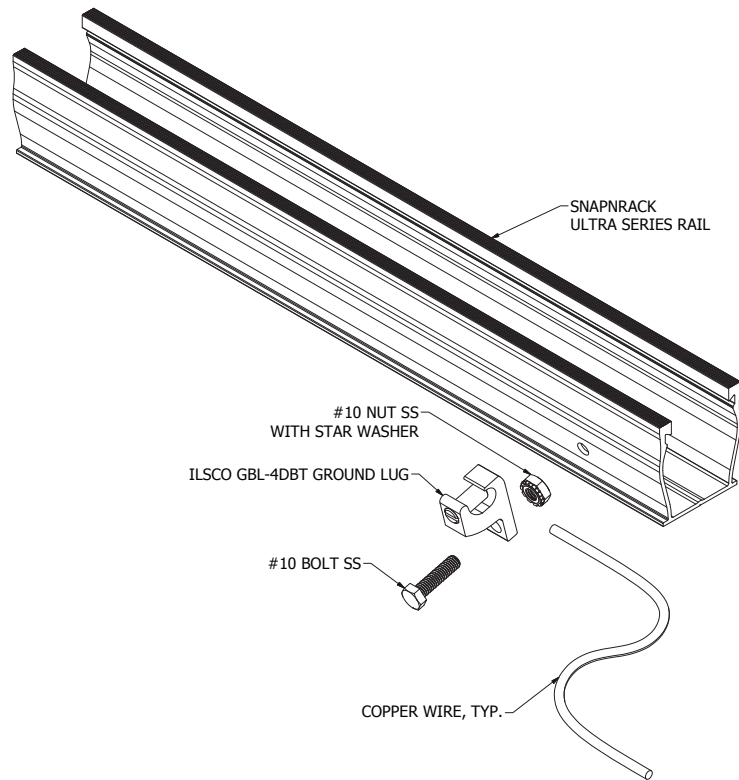

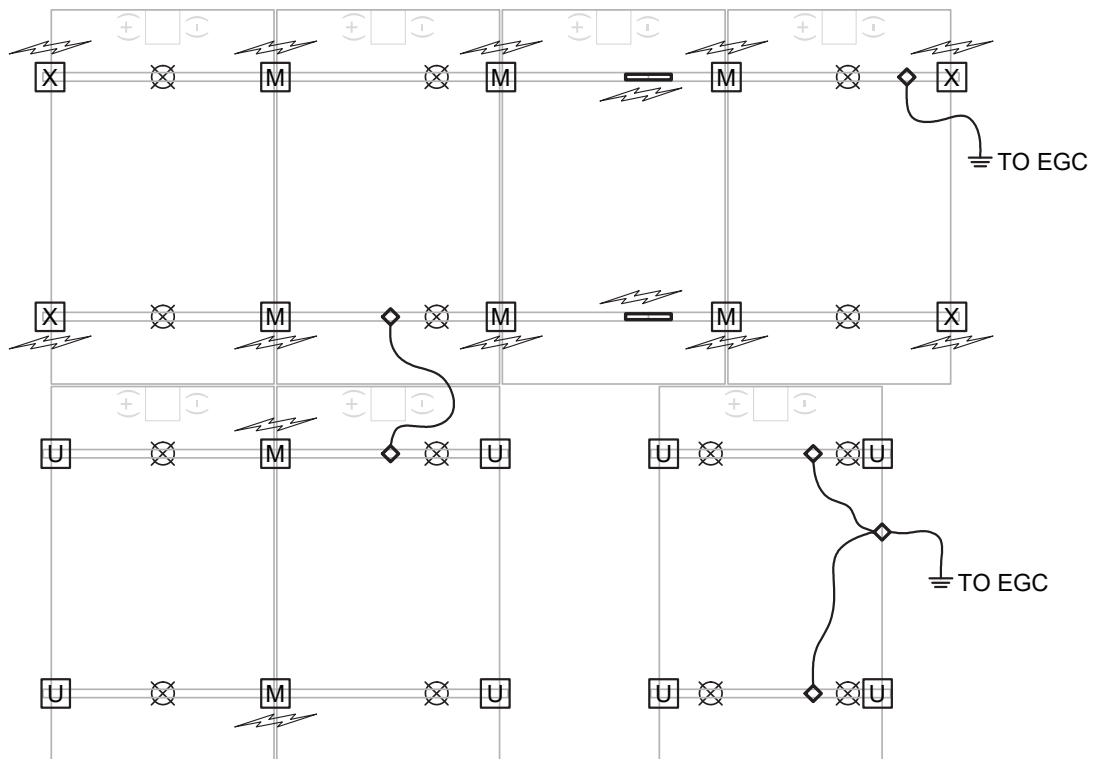

IlSCO Lay-in Lug Assembly

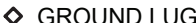

Ground Path Details



- | | | | | |
|--|---|---|--|---|
|  |  |  |  |  |
|  |  | | | |
| <p> M MODULE CLAMP
 M = MIDCLAMP
 X = X-END CLAMP
 U = UNIVERSAL END CLAMP </p> | | | | |

Ground Path Details - SolarEdge

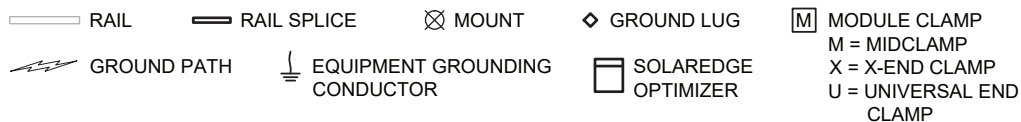
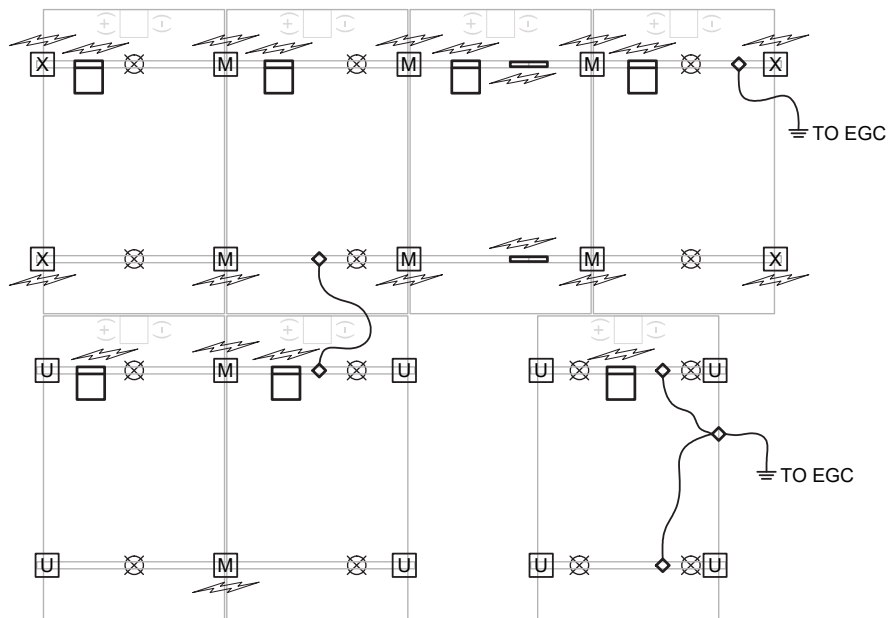

Ground Path Details - Enphase

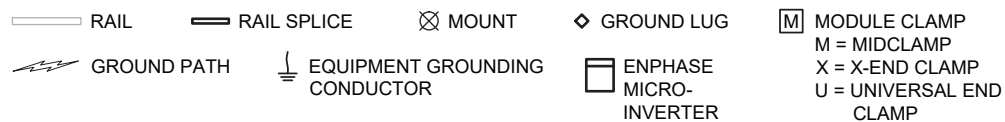
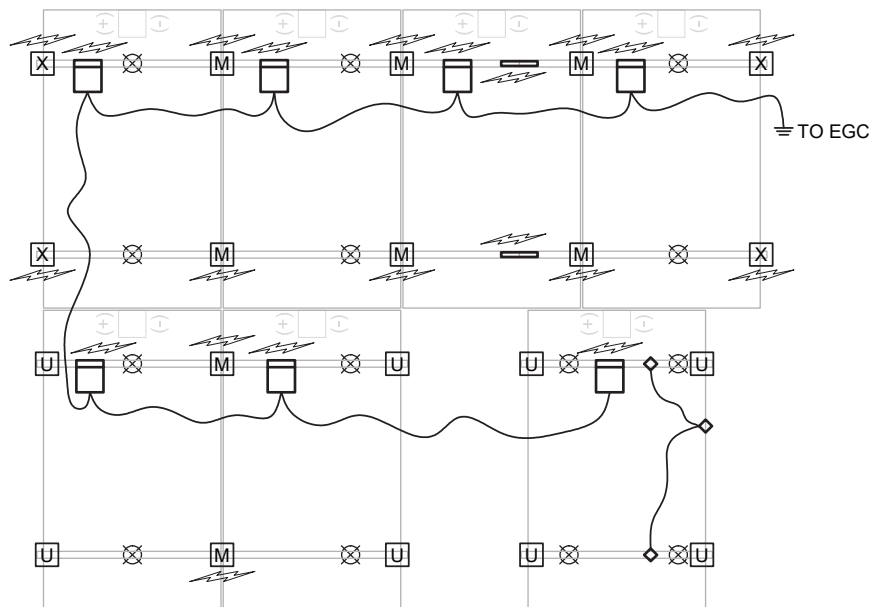

INSTALLATION INSTRUCTIONS - SNAPNRACK GROUND LUG

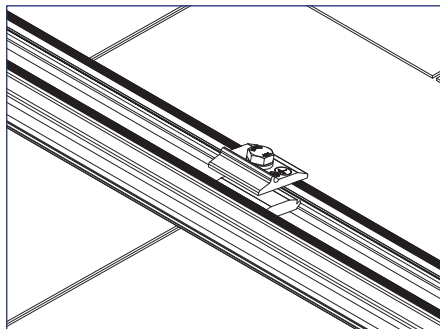

1) Snap the SnapNrack Ground Lug into the rail channel on one rail per module row.

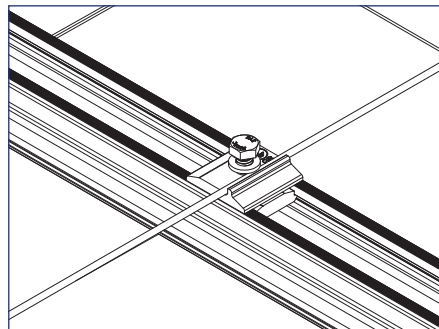

2) Place grounding conductor into slot underneath split ring washer.

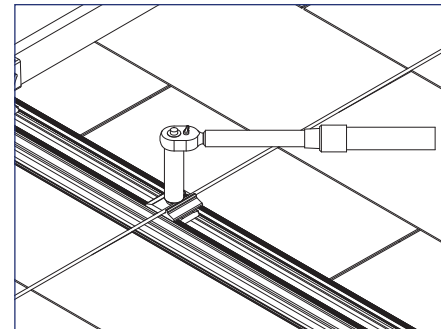

3) Tighten hardware to 16 ft-lbs.

Install Note:

SnapNrack Ground Lug may be used in side or top channel, and may be rotated 90 degrees relative to slot to facilitate running copper across top of rails.

Install Note:

SnapNrack Ground Lug only Listed for use with 6-12 AWG solid copper conductor.

INSTALLATION INSTRUCTIONS - ILSCO LAY-IN LUG

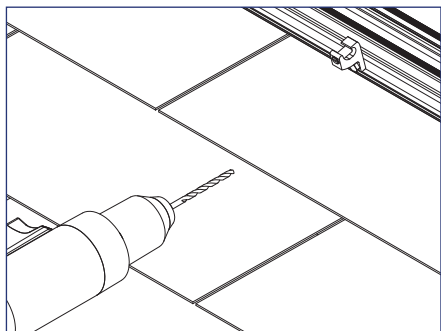

1) Drill and deburr a 1/4" hole in the back side of the rail for the IlSCO lug to attach to, place the bolt through the hole, and attach the lug assembly on one rail per module row.

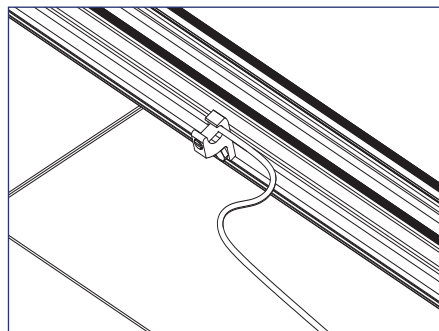

2) Place grounding conductor into slot.

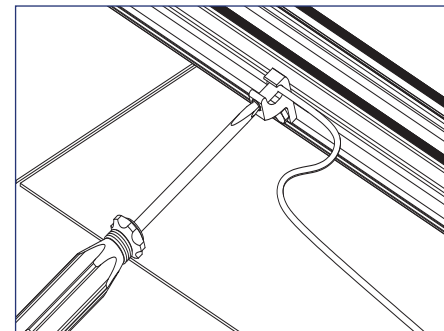

3) Tighten set screw per IlSCO's recommendation (see below).

Install Note:

Torque rail connection to 35 in-lbs.

Install Note:

Torque set screw to 20 in-lbs for #10-#14 solid and stranded copper, 25 in-lbs for #8 stranded copper, and 35 in-lbs for #4-#6 stranded copper.

Note:

- System has been evaluated to a maximum overcurrent device (OCD) protection level of 20 Amps.
- Universal End Clamp (UEC) does not bond module to rail. Be sure to separately ground any modules that are only secured by UECs, especially during servicing.
- SnapNrack recommends that bare copper never come into contact with aluminum.
- SnapNrack Ground Lug: torque bolt to 16 ft-lbs. The Ground Lug may be used in side or top channel. It may be rotated 90 degrees relative to slot to facilitate running copper across top of rails.
- Grounding with a standard IlSCO GBL-4DBT Lug is a listed alternate and requires drilling of a hole in the rail.
- IlSCO hardware connection to rail: 5 ft-lbs. Torque for lug set screw: #10-#14 solid and stranded copper- 20 in-lbs, #8 stranded copper- 25 in-lbs, #4-#6 stranded copper- 35 in-lbs.

Ground Path Details - DynoBond

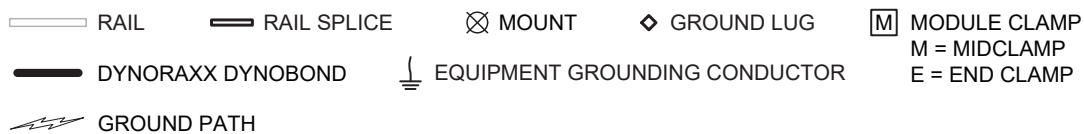
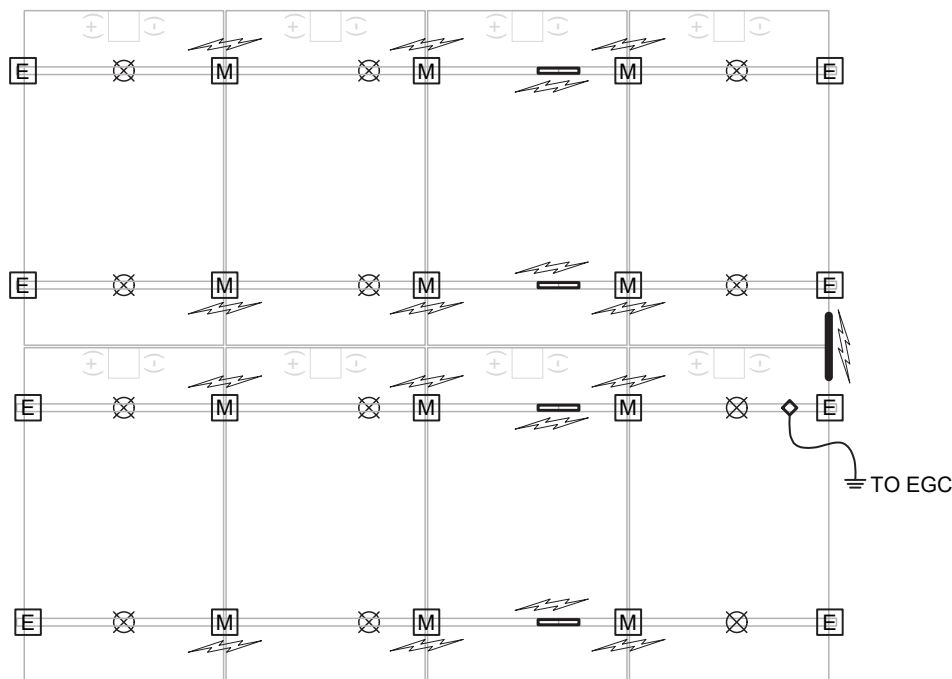

R/C (QIMS2), DynoRaxx (E357716) photovoltaic bonding jumper cat. no. DynoBond is an optional component that may be used with this system. The DynoBond jumper has been evaluated to provide module to module bonding. The DynoBond device attaches to the frame flange of adjacent modules.

GROUNDING MARKING DETAILS

All components included in the Ultra Rail UL 2703 Listing for grounding/bonding are packaged and marked with the UL logo, SnapNrack File E359313, and “PV Mounting System”

The SnapNrack Ground Lug is marked with the ground symbol
 IlSCO Ground Lugs have green colored set screws or bolts to indicate connection to the grounding electrode conductor

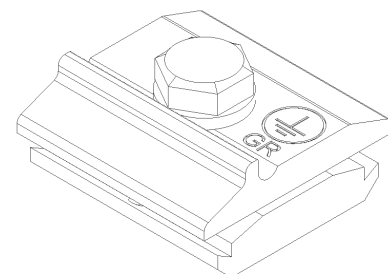
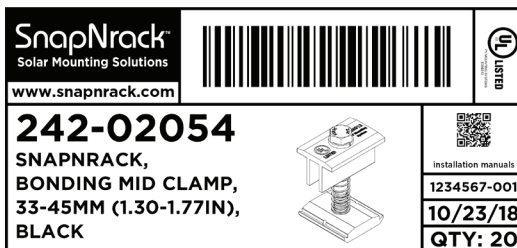

INSTRUCTION FOR MAINTAINING THE GROUNDING BONDING WHEN REMOVING A MODULE FOR SERVICING

CAUTION: Module removal may disrupt the bonding path and could introduce the risk of electric shock. Additional steps may be required to maintain the bonding path. Modules should only be removed by qualified persons in compliance with the instructions in this manual.

Module removal is not presented as a frequently expected occurrence and will not be required as part of routine maintenance.

Scenarios that could result in a disruption of the bonding path are, for example irregularly-shaped arrays, arrays consisting of individual rows, and any other scenario where module removal could disrupt the bonding path.

In most cases, the removal of a module for servicing will not disturb or break grounding continuity because SnapNrack Ultra Rail systems are bonded through the rail. If a module is to be removed that will break continuity, these are the steps that must be taken to maintain a continuously bonded SnapNrack Ultra Rail system.

Required Tools

- Socket Wrench
- Torque Wrench
- 1/2" Socket
- 7/16" Socket

Required Materials

- 1 #10 Or Larger Bare Copper Conductor
- 2 SnapNrack SKU 242-02101
- 3 IlSCO Part No. SGB-4
- 4 DnoRaxx Dynobond™

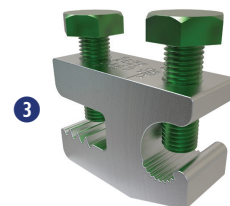

Maintaining the Grounding Bonding When Removing a Module

JUMPER ASSEMBLY INSTRUCTION & INSTALLATION

CAUTION: Do Not Remove the Module until the Jumper is installed

1) Identify the existing ground path at the location of module removal and choose an appropriate length of #10 bare copper to bridge the soon to be broken ground path.

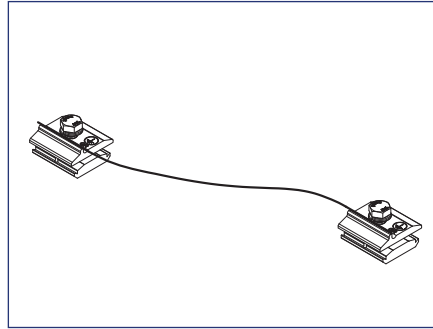

Example of assembled bonding jumper using (2) SnapNrack Ground Lugs

2) Attach one ground lug to each end of #10 bare copper wire. See recommended options below:

1. (2) SnapNrack SKU: 242-02101
2. (2) IlSCO part no. SGB-4
3. (1) SnapNrack part no. 242-02101 & (1) IlSCO part no. SGB-4
4. (1) DroRaxx DynoBond™

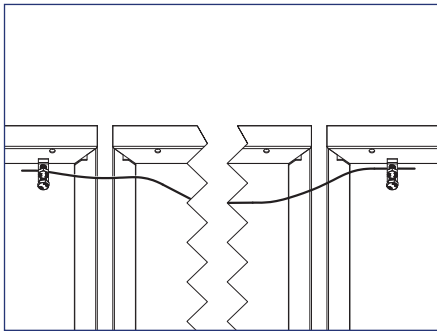

3) Before the module is removed, attach the assembled bonding jumper. Depending on where the module will be removed and choice of ground lug, jumper attachment locations will vary.

- IlSCO SGB-4 lugs can be attached to SnapNrack Ultra Rail, or module frames
- SnapNrack Ground Lug can only be attached to SnapNrack Ultra Rail
- DynoRaxx DynoBond™ is approved and appropriate when a short bonding jumper is needed from module to module, or module to rail

4) Service the array. With the bonding jumper installed, it is now safe to remove the module for service or maintenance.

5) After Servicing the array reinstall the module and original ground path. Only then remove the bonding jumper.

Caution: Do not remove the bonding jumper until original ground path is established.

Ultra Rail has been tested with the following UL Listed modules:

The Ultra Rail System employs top-down clamps which have been evaluated for frame-to-system bonding, at specific mounting torques and with the specific modules listed below.

Ultra Rail has been tested with the following UL Listed module series: The Ultra Rail System employs top-down clamps which have been evaluated for frame-to-system bonding, at specific mounting torques and with the specific module series listed below. All wattage values are covered.

Manufacturer	Model	
Aptos Solar	DNA-120-MF23-XXX DNA-120-BF23-XXX DNA-144-MF23-XXX DNA-144-BF23-XXX DNA-120-MF26-XXXW DNA-144-MF26-XXXW	DNA-120-BF26-XXXW DNA-144-BF26-XXXW DNA-108-BF10-xxxW DNA-120-BF10-xxxW DNA-108-MF10-xxxW
Boviet Solar	BVM6610P-XXX BVM6610M-XXX	BVM6612P-XXX BVM6612M-XXX
Canadian Solar	CS6K-XXX-M CS6K-XXX-M-SD CS6K-XXX-P CS6K-XXX-P-SD CS6K-XXX-MS CS6P-XXX-M CS6P-XXX-P CS6P-XXX-P-SD CS6V-XXX-M CS6V-XXX-P CS6X-XXX-P CS3K-XXX-P CS3K-XXX-MS	CS3U-XXX-MS CS3U-XXX-P CS1K-XXX-MS CS1H-XXX-MS CS1H-XXX-MS-AB CS3W-XXX-P CS3N-XXX-MS CS1Y-XXX-MS CS3W-XXXMB-AG CS3Y-XXXMB-AG CS6W-XXXMB-AG CS6R-XXXMS-HL CS3W-XXX-MS
CertainTeed	CTXXXHC11-06	
Chint Solar	CHSM6612M-XXX CHSM6612M(BL)-XXX CHSM6612M/HV-XXX	CHSM72M-HC-XXX* (Astro 4) CHSM72M-HC-XXX* (Astro 5)
Dehui Solar	DH-M760B-XXXW DH-M760W-XXXW DH-M772W-XXXW	DH-M760F-XXXW* DH-M772F-XXXW*
ET Solar	ET-P660XXXBB ET-P660XXXWB ET-P660XXXWW ET-P660XXXWWG	P660XXXWB/WW P660XXXWWG M660XXXBB M660XXXWW
Freedom Forever	FF-MP-BBB-xxx	
Hanwha Q Cells	Q.PEAK BLK-G3.1-XXX Q.PEAK G3.1-XXX Q.PLUS BFR-G3.1-XXX	Q.PEAK DUO-L-G7.2-XXX Q.PEAK DUO-L-G7.3-XXX Q.PEAK DUO-L-G6-XXX

Manufacturer	Model	
Hanwha Q Cells	B.LINE PLUS BFR-G4.1-XXX	Q.PEAK DUO-L-G6.2-XXX
	B.LINE PRO BFR-G4.1-XXX	Q.PEAK DUO-L-G6.3-XXX
	Q.BASE GY-XXX	Q.PEAK DUO-L-G8-XXX
	Q.PEAK BFR-G4-XXX	Q.PEAK DUO-L-G8.1-XXX
	Q.PEAK BFR-G4.1-XXX	Q.PEAK DUO-L-G8.2-XXX
	Q.PEAK BLK-G4.1-XXX	Q.PEAK DUO-L-G8.3-XXX
	Q.PEAK BLK-G4.1/TAA-XXX	Q.PEAK DUO-G5/SC-XXX
	Q.PEAK G4-XXX	Q.PEAK DUO-BLK-G5/SC-XXX
	Q.PEAK G4.1-XXX	Q.PEAK DUO-G6+/SC-XXX
	Q.PEAK G4.1/MAX-XXX	Q.PEAK DUO-BLK-G6+/SC-XXX
	Q.PEAK G4.1/TAA-XXX	Q.PEAK DUO BLK-G6+/AC-XXX
	Q.PLUS BFR-G4-XXX	Q.PEAK DUO-ML-G9-XXX
	Q.PLUS BFR-G4.1-XXX	Q.PEAK DUO-BLK-ML-G9-XXX
	Q.PLUS BFR-G4.1/TAA-XXX	Q.PEAK DUO-BLK-G9-XXX
	Q.PLUS G4-XXX	Q.PEAK DUO-BLK-G9+-XXX
	Q.PLUS GY-XXX	Q.PEAK DUO-ML-G9+-XXX
	Q.PLUS BFR-GY-XXX	Q.PEAK DUO-BLK-ML-G9+-XXX
	Q.PRO BFR-G4-XXX	Q.PEAK DUO-G5/TS-XXX
	Q.PRO BFR-G4.1-XXX	Q.PEAK DUO BLK-G5/TS-XXX
	Q.PRO BFR-G4.3-XXX	Q.PEAK DUO-G6/TS-XXX
	Q.PRO BFR-GY-XXX	Q.PEAK DUO BLK-G6/TS-XXX
	Q.PRO BLK-GY-XXX	Q.PEAK DUO-G6+/TS-XXX
	Q.PRO G4-XXX	Q.PEAK DUO BLK-G6+/TS-XXX
	Q.PRO GY-XXX	Q.PEAK DUO XL-G9.2-XXX
	Q.PRO GY/SC-XXX	Q.PEAK DUO XL-G9.3-XXX
	Q.PEAK DUO-G5-XXX	Q.PEAK DUO XL-G9.3/BFG-XXX
	Q.PEAK DUO-BLK-G5-XXX	Q.PEAK DUO XL-G10.2-XXX
	Q.PLUS DUO-G5-XXX	Q.PEAK DUO XL-G10.3/BFG-XXX
	Q.PEAK DUO-G7-XXX	Q.PEAK DUO XL-G10.3-XXX
	Q.PEAK DUO-BLK-G7-XXX	Q.PEAK DUO XL-G10.c-XXX
	Q.PEAK DUO-G7.2-XXX	Q.PEAK DUO XL-G10.d-XXX
	Q.PEAK DUO-G6+-XXX	Q.PEAK DUO L-G8.3/BFG-XXX
	Q.PEAK DUO-BLK-G6+-XXX	Q.PEAK DUO L-G8.3/BGT-XXX
	Q.PEAK DUO-G6-XXX	Q.PEAK DUO ML-G10-XXX
	Q.PEAK DUO-BLK-G6-XXX	Q.PEAK DUO BLK ML-G10+-XXX
	Q.PEAK DUO-G8+-XXX	Q.PEAK DUO ML-G10+-XXX
	Q.PEAK DUO-BLK-G8+-XXX	Q.PEAK DUO BLK ML-G10-XXX
	Q.PEAK DUO-G8-XXX	Q.PEAK DUO ML-G10.a+-XXX
	Q.PEAK DUO-BLK-G8-XXX	Q.PEAK DUO BLK ML-G10.a+-XXX
	Q.PLUS L-G4-XXX	Q.PEAK DUO ML-G10.a-XXX
	Q.PLUS L-G4.1-XXX	Q.PEAK DUO BLK ML-G10.a-XXX
	Q.PLUS L-G4.2-XXX	Q.PEAK DUO BLK ML-G10.a+/TS-XXX
	Q.PEAK L-G4.1-XXX	Q.PEAK DUO G10-XXX
	Q.PEAK L-G4.2-XXX	Q.PEAK DUO BLK G10-XXX
	Q.PLUS DUO-L-G5-XXX	Q.PEAK DUO G10+-XXX

Grounding Specifications

Manufacturer	Model	
Hanwha Q Cells	Q.PLUS DUO-L-G5.1-XXX Q.PLUS DUO-L-G5.2-XXX Q.PLUS DUO-L-G5.3-XXX Q.PEAK DUO-L-G5.2-XXX Q.PEAK DUO-L-G5.3-XXX Q.PEAK DUO-L-G7-XXX Q.PEAK DUO-L-G7.1-XXX	Q.PEAK DUO BLK G10+-XXX Q.PEAK DUO BLK G10+/AC XXX Q.PEAK DUO BLK G10+/HL XXX Q.PEAK DUO XL-G11.3 XXX Q.PEAK DUO XL-G11.3 BFG XXX Q.TRON-G1+ XXX Q.TRON BLK-G1+ XXX
Hanwha SolarOne	HSL60P6-PB-2-XXXQ	HSL60P6-PB-4-XXXQ
Heliene	60M-XXX 60P-XXX	72M-XXX 72P-XXX
HT-SAAE	HT60-166M-XXX	HT60-182M-XXX
Hyundai	HiS-MXXXRG HiS-SXXXRG HiS-SXXXRW HiS-MXXXMG HiS-SXXXMG HiD-SXXXRG	HiA-SXXXMS HiS-SXXXXY HiS-SXXXYI HiS-SxxxYH(BK) All may be followed by (BK)
Hyperion/Runergy	HY-DH108P8-XXX(Y)	
JA Solar	JAM6-60-XXX/SI JAP6-60-XXX/3BB JAM60S09-XXX/PR JAM60S10-XXX/MR JAM60S10-XXX/PR JAM60S12-XXX/PR JAP72S01-XXX/SC JAM72S09-XXX/PR	JAM72S10-XXX/MR JAM72S10-XXX/PR JAM72S12-XXX/PR JAP6(k)-72-XXX/4BB JAM60S17-XXX/MR JAM54S30-XXX/MR JAM54S31-XXX/MR JAM72D30-XXX/MB
Jinko Solar	JKMXXXM-60 JKMXXXM-60L JKMXXXM-60HL JKMXXXM-60HBL JKMXXXP-60 JKMXXXP-60-J4 JKMXXXP-60-V JKMXXXP-60B-J4 JKMXXXPP-60 JKMXXXPP-60-V JKMXXXM-72 JKMXXXM-72L-V JKMXXXP-72	JKMXXXP-72-V JKMXXXPP-72 JKMXXXPP-72-V JKMSXXXP-72 JKMXXXM-72HL-V JKMXXXM-72HL-TV JKMXXXM-72HBL JKMXXXM-6TL3-B JKMXXXM-6RL3-B JKMXXXM-7RL3-V JKMXXXM-7RL3-TV JKMXXXM-72HL4-V JKMXXXM-72HL4-TV
Kyocera	KUXXX-6YYY	KUXXX-8YYY
LG	LGXXXN1C-A5 LGXXXN1K-A5 LGXXXQ1C-A5 LGXXXQ1K-A5	LGXXXA1C-V5 LGXXXM1C-L5 LGXXXM1K-L5 LGXXXN1C-N5

Manufacturer	Model	
LG	LGXXS1C-A5 LGXXN2C-B3 LGXXN2W-B3 LGXXN1C-G4 LGXXN1K-G4 LGXXS1C-G4 LGXXN2C-G4 LGXXN2K-G4 LGXXN2W-G4 LGXXS2C-G4 LGXXS2W-G4 LGXXN1C-V5 LGXXN1W-V5 LGXXN2T-V5 LGXXN2T-J5 LGXXN1T-V5	LGXXN1K-L5 LGXXN1K-A6 LGXXN1C-A6 LGXXN1W-A6 LGXXQ1C-A6 LGXXQ1K-A6 LGXXM1K-A6 LGXXM1C-A6 LGXXA1C-A6 LGXXQAC-A6 LGXXQAK-A6 LGXXN1K-B6 LGXXN2W-E6 LGXXN2T-E6 LGXXN1K-E6 LGXXN3K-V6
Longi	LR6-60-XXXM LR6-60BK-XXXM LR6-60HV-XXXM LR6-60PB-XXXM LR6-60PE-XXXM LR6-60PH-XXXM LR6-60HPB-XXXM LR6-60HPH-XXXM	LR4-60HPB-XXXM LR4-60HIB-XXXM LR4-60HPH-XXXM LR4-60HIH-XXXM LR6-60HIH-XXXM LR6-60HIB-XXXM LR4-72HPH-XXXM
Meyer Burger	Meyer Burger Black*	Meyer Burger White*
mSolar	TX16-XXX120BB	
Mission Solar	MSEXXS05T MSEXXS05K MSEXXSQ5T MSEXXSQ5K MSEXXM4J MSEXXM6J MSEXXS06W MSEXXS04J MSEXXS06J MSEXXSQ6S MSEXXSQ4S	MSEXXS8K MSEXXS8T MSEXXS9S MSE60AXXX MSEXXTS60 MSEXXS5K MSEXXS5T MSEXXS6S MSEXXS6W MEXxxSX5R
Next Energy Alliance	USNEA-XXXM3-60 USNEA-XXXM3B-60	USNEA-XXXM3-72 USNEA-XXXM3B-72
Panasonic	VBHNXXXKA01 VBHNXXXKA02 VBHNXXXSA16 VBHNXXXKA03	VBHN325SA17E VBHXXRA18N VBHXXRA03K EVPVXXX(K)

Manufacturer	Model	
Panasonic	VBHNXXXKA04 VBHNXXXSA17 VBHNXXXSA18	EVPVXXXH EVPVXXXPK
Phono Solar	PSXXXM-20/U PSXXXMH-20/U PSxxxM8GF-24/TH PSxxxM8GFH-24/TH	PSxxxM8GF-18/VH PSxxxM8GFH-18/VH PSxxxM6-24/TH
REC	RECXXXPE RECXXXPE-BLK RECXXTP RECXXTP-BLK RECXXTP IQ RECXXTP2 RECXXTP2-BLK RECXXXNP RECXXTP2M RECXXTP72 RECXXXPE72 RECXXXPE72XV RECXXTP2M 72 RECXXTP2M 72 BLK	RECXXTP2M 72 BLK2 RECXXTP2SM 72 RECXXTP2SM 72 BLK RECXXTP2SM 72 BLK2 RECXXXAA RECXXTP3 RECXXTP3M RECXXTP4 RECXXXAA Pure RECxxxAA Pure-R RECXXXNP2 RECxxxNP3 All may be followed by BLK or BLACK
Renesola	JCXXXM-24/Bb	JCXXXM-24/BBh
SEG Solar	SEG-400-BMB-HV SEG-400-BMB-TB	SEG-xxx-BMD-HV SEG-xxx-BMD-TB
Silfab	SLAXXX-M SLAXXX-P SSAXXX-M SSAXXX-P SILXXXBL SILXXXML SILXXXNL SLGXXX-M SLGXXX-P SSGXXX-M SSGXXX-P	SILXXXNT SILXXXHL SILXXXBK SILXXXHC SILXXXNU SILXXXNX SILXXXHN SILXXXBG SIL-xxxHC+ SIL-xxxHM

Manufacturer	Model	
Solaria	Solaria PowerXT-XXXXR-PX Solaria PowerXT-XXXXR-BX Solaria PowerXT-XXXXR-AC	Solaria PowerXT-XXXXR-PM Solaria PowerXT-XXXXR-PM-AC
SolarWorld	SWXXX-Mono	SWXXX-Mono XL
Suniva	MVX-XXX-60-5-701 MVX-XXX-60-5-7B1 OPT-XXX-60-4-100	OPT-XXX-60-4-1B0 OPT-XXX-60-4-800 OPT-XXX-60-4-8B0
Sunpower	SPR-EYY-XXX SPR-XYX-XXX SPR-EYY-XXX SPR-XYX-XXX SPR-P17-XXX-COM SPR-P19-XXX-COM SPR-AXXX-G-AC	SPR-AXXX SPR-AXXX-BLK-G-AC SPR-AXXX-BLK SPR-MXXX-H-AC SPR-MXXX SPR-MXXX-BLK-H-AC SPR-MXXX-BLK
SunSpark	SST-XXXM3-60 SST-XXXM3B-60	SST-XXXM3-72 SST-XXXM3B-72
Talesun	TP660M-XXX TP660P-XXX	TP672M-XXX TP672P-XXX
Tesla	TXXXS	TXXXH
Trina	TSM-XXXDD05(II) TSM-XXXDD05A.05(II) TSM-XXXDD05A.08(II) TSM-XXXDD05A.082(II) TSM-XXXPA05 TSM-XXXPA05.05 TSM-XXXPA05.08 TSM-XXXPD05 TSM-XXXPD05.002 TSM-XXXPD05.05 TSM-XXXPD05.05S TSM-XXXPD05.08 TSM-XXXPD05.082 TSM-XXXPD05.08D TSM-XXXPD05.08S	TSM-XXXDD06M.05(II) TSM-XXXDE15H(II) TSM-XXXDE15M(II) TSMXXXDD05H.05(II) TSMXXXDE06X.05(II) TSMXXXDE09.05 TSMXXXDE15V(II) TSMXXXDEG15VC.20(II) TSMXXXDEG18MC.20(II) TSM-XXXDE19 TSMXXXDEG19C.20 TSMXXXDEG21C.20 TSMXXXDE09C.05 TSMXXXDE09C.07 TSM-xxxNE09RC.05

Manufacturer	Model	
Vikram Solar	SOMERA VSMHBB.60.XXX.05	PREXOS VSMDHT.60.XXX.05
	SOMERA VSMH.72.XXX.05	PREXOS VSMDHT.72.XXX.05
VSUN	VSUNXXX-144BMH-DG	VSUNXXX-108BMH
	VSUNXXX-120BMH	
Yingli	YLXXXA-29b	YLXXXP-29b
ZNShine	ZXM6-60-XXX/M	ZXM6-NH144-XXXM
	ZXM6-NH120-XXXM	ZXM7-SH108-XXXM

Ultra Rail has been tested with the following Module Level Power Electronic (MLPE) devices:

The UR-40 and UR-60 mounting systems have been tested with the following UL/NRTL Listed Module Level Power Electronic (MLPE) Devices. The back plates of the MLPEs have been evaluated for bonding to UR-40 and UR-60 rail through the MLPE Attachment Kit.

AP Smart	RSD-S-PLC	
Celestica International	DG-006-F001201x	DG-006-F001401x
Delta Electronics	GPI00010105	
Enphase	C250	IQ7PLUS-72-2-US
	M215	IQ7PLUS-72-B-US
	M250	IQ8-60
	IQ6-60-2-US	IQ8PLUS-72
	IQ6PLUS-72-2-US	IQ8A-72
	IQ7-60-2-US	IQ8H-208-72
Generac	Optimizer model S2502	
Ginlong Technologies	Solis-RSD-1G	Solis-MLRSD-R2-1G
	Solis-MLRSD-R1-1G	
SolarEdge	P300-5NC4ARS	P505
	P320-5NC4ARS	P730
	P370-5NC4AFS	P800p
	P400-5NC4AFS	P850
	P320	P860
	P340	P950
	P370	P1100
	P400	P1101
	P401	S440
	P405	S500
SMA	RSB-2S-US-10	
Tigo	TS4-R-F	TS4-R-S-DUO
	TS4-R-M	TS4-A-F
	TS4-R-O	TS4-A-2F
	TS4-R-S	TS4-A-O
	TS4-R-M-DUO	TS4-A-S
	TS4-R-O-DUO	

Notes:

AP Smart RSD-S-PLC, Ginlong Solis-MLRSD-R1-1G and Solis-MLRSD-R2-1G, and all Tigo models have not been investigated for bonding since the enclosures are constructed entirely of polymeric materials.

The SolarEdge P320 and P370 models are both frame mount and rail mount. All other PXXX series models are rail mount.

Functionality of these devices was not evaluated.

Not all UR-40 and UR-60 components have been evaluated for Mechanical Loading. The following structural components have been evaluated:

UR-40 Rail, UR-60 Rail, UR-40/UR-60, Ultra Rail Mid Clamp, Ultra Rail End Clamp, Mid Clamp, X End Clamp, Universal End Clamp, UR-40 and UR-60 Splice, SpeedSeal™ Foot for UR40/UR60, UR-40/UR-60 Composition Mount Kits, Standard Standoff for UR-40/UR-60, Four Hole Standoff for UR-40/UR-60, Heavy Duty Standoff for UR-40/UR-60, Metal Roof Base Standoff for UR-40/UR-60, UR-40/UR-60 Corrugated Block, Standard Base Seam Clamp for UR-40/UR-60, Wide Base Seam Clamp for UR-40/UR-60, UR-40/UR-60 Universal Tile Hook, UR-40/UR-60 Flat Tile Hook, Flat Tile Replacement Kit for UR-40/UR-60, S Tile Replacement Kit for UR-40/UR-60, W Tile Replacement Kit for UR-40/UR-60, UR-40/UR-60 Tile Hook F, UR-40/UR-60 Tile Hook WS, UR-40/UR-60 Hanger Bolt Clamp, UR-40/UR-60 Tilt Kits.

The following non-structural components have not been evaluated for mechanical loading:

Skirt Assembly, MLPE Frame Attachment Kit, MLPE Rail Attachment Kit, Smart Clips, Ground Lugs.

The UL Listing covers mechanical load ratings for the following span lengths, module orientations and downforce, uplift, and down-slope ratings:

Span	Orientation	Direction	Load Rating (lb/ft ²)
4 or 6 feet	Long Side or Short Side Mounting	Downforce	10
		Uplift	5
		Down-Slope	5

UR-40 and UR-60 have been evaluated for Mechanical Loading with all UL/NRTL Listed Photovoltaic modules listed in this manual for the minimum mechanical load ratings per UL 2703.