

# SnapNrack™

Solar Mounting Solutions

---

## TopSpeed Universal

Railless Residential Roof Mount System  
Installation Manual

---



2703 Listed — PV Mounting System

[snapnrack.com](https://snapnrack.com)

SnapNrack's primary goal is to provide our customers with the lowest possible installed cost for mounting residential solar modules, without compromising the values the industry has come to expect: ease of use, quality, aesthetics, and safety. Designing with this goal in mind, we are proud to present the SnapNrack TopSpeed Universal (formerly RL Universal) Solar Mounting System.

SnapNrack has created a rail less system combining great features and benefits we are known for, with our Ultra Rail system and the most up to date technical innovation in the industry, thus reducing parts while driving down labor, material, and total installation costs. Designed to work with standard module frames, achieving UL 2703 Listing for Grounding/Bonding and Fire Classification, providing integrated wire management, aesthetics and our industry leading "Snap-In" features, SnapNrack is providing the simplest and most cost effective solar mounting solution on the market with TopSpeed Universal and SpeedSeal™ Track.

## Benefits of Installing the SnapNrack TopSpeed Universal System

### Install With Very Few Parts

This elimination of parts leads to a lower estimated system cost for both the installer and home owner.

### Built in Wire Management and Aesthetics

Extensive wire management solutions have been designed specifically for the system that adapts to multiple possible mounting positions.

The system is designed to be aesthetically pleasing and sturdy with a SkirtRail that provides considerable strength at the leading edge and an elegant look for those seeking high end looking systems.

### Install TopSpeed Universal with SpeedSeal™ Track

SpeedSeal™ Track features an innovative design that incorporates flashing reliability into a single roof attachment. This eliminates loosening layers of composition and removing nails with a pry bar, leading to less damage to the roof, minimized potential roof leaks, and much faster installs.

### Install TopSpeed Universal with SpeedSeal™ DeckTrack

As well as all of the benefits associated with the standard SpeedSeal™ Technology, SpeedSeal™ DeckTrack does not require rafter attachment. Simply attaching to the roof decking removes the requirement for pilot holes, and potential rafter misses that can cause leaks.

### Install TopSpeed Universal with AlphaTrack / DeltaTrack

AlphaTrack and DeltaTrack are an evolution of the SpeedSeal™ + Technology products. The mounts feature an innovative design that incorporates a pre-applied butyl sealant allowing for a much faster install experience while minimizing potential roof leaks. Each mount is designed for direct to deck mounting - AlphaTrack attaches to the roof decking using two (2) proprietary SnapNrack DeckAnchor™ fasteners and the DeltaTrack attaches with four (4) #14 wood screws. While both products are designed with deck mounting at the forefront, the AlphaTrack and DeltaTrack can be rafter mounted.

## Project Plans

Certification Details . . . . .	4
Component Details . . . . .	5
Pre-Installation Requirements . . . . .	9

## Installation Steps

System Layout . . . . .	10
Composition Shingle Installation . . . . .	11
TopSpeed Universal Mount & SkirtRail Installation . . . . .	15
Wire Management . . . . .	18
MLPE Attachment . . . . .	19
Module Installation . . . . .	25
Grounding Specifications . . . . .	31
Maintaining the Grounding Bonding When Removing a Module . . . . .	32
List of Approved Modules. . . . .	34
List of Approved MLPE Devices. . . . .	39

## Certification Details

---

SnapNrack TopSpeed Universal (also known as RL Universal) system has been evaluated by Underwriters Laboratories (UL) and Listed to UL Standard 2703 for Grounding/Bonding, and Fire Classification.

### **Grounding/Bonding**

---

Only specific components have been evaluated for bonding, and are identified as being in the ground path. The TopSpeed Universal components that have been evaluated for bonding are the Mount Assembly, Ridge Mount Assembly, Link Assembly, SkirtRail, Flash Track, or SpeedSeal™ Track, SpeedSeal™ DeckTrack, Ground Lugs, OmniLug, and Smart Clips.

The following system components are not required to be bonded to the system based on the exceptions in clause 9.1 of UL 2703 1st Ed.: SkirtRail Spacer, Umbrella Bolt, Flashing and Positioning Springs. Wire management clips are utilized to route conductors away from these components and must be assembled according to the instructions.

This mounting system may be used to ground and/or mount a PV module complying with UL 1703 only when the specific module has been evaluated for grounding and/or mounting in compliance with the included instructions. See Appendix A for the list of modules tested with the TopSpeed Universal system for integrated grounding.

Ground Lugs have been evaluated to both UL 467 and UL 2703 Listing requirements. The following ground lugs have been approved for use: SnapNrack model 242-02021, 242-92202, 242-10034, and IlSCO models GBL-4DBT and SGB-4.

The following components have been evaluated for bonding as the fault current ground path: Mount Assembly, Ridge Mount Assembly, Link Assembly, Flash Track or SpeedSeal™ Track, SpeedSeal™ DeckTrack, and Ground Lugs. In order to maintain the Listing for bonding, wire management clips must be assembled to route conductors away from parts that have not been evaluated for bonding.

A Listed (QIMS) and Unlisted Component (KDER3) grounding lug, SnapNrack part no. 242-92202, is attached to the module frame flange, Flash Track, SpeedSeal™ Track, SpeedSeal™ DeckTrack or Ridge Mount Track for the normal attachment of a Grounding Electrode Conductor, which provides bonding within the system and eventual connection to a Grounding Electrode, as required by the U.S. NEC. Details of part no. 242-92202 can be found in Volume 1, Section 4, and Volume 2, Section 2. When this method is used, the grounding symbol is stamped onto the body of the ground lug to identify the grounding terminal.

An alternate method of grounding, A UL Listed (QIMS) and Unlisted Component (KDER3) grounding lug, SnapNrack part no. 242-10034 is attached to the Flash Track, SpeedSeal™ Track, or SpeedSeal™ DeckTrack. Details of part no. 242-10034 can be found in Volume 1, Section 4, and Volume 2, Section 3. When this method is used, the grounding symbol is stamped onto the body of the ground lug to identify the grounding terminal.

An alternate method of grounding, a UL Listed (KDER and QIMS) grounding lug, IlSCO (E34440 and E354420) model SGB-4 is attached to the module frame flange, Flash Track, SpeedSeal™ Track, SpeedSeal™ DeckTrack, or Ridge Mount Track. When this method is used, the grounding terminal is identified by the green colored screws of the lug.

An alternate method of grounding, a UL Listed (KDER and QIMS) grounding lug, IlSCO (E34440 and E354420) model GBL-4BDT is attached to the module frame flange through the specified hardware and torque values. When this method is used, the grounding terminal is identified by the green colored set screw of the lug.

An alternate method of grounding, Enphase R/C (QIKH2)(QIMS2) model M250, M215 & C250 is bonded

to the Listed PV module frame by the Enphase R/C (QIMS2) Model EFM-XXMM anodization piercing mounting/clamping kit. The total roof-mounted PV system is bonded (modules and microinverters) together and the assembly is bonded to ground through the Enphase R/C (QIMS2) Engage Cables; Model ETXX-240, ETXX-208 or ETXX-277, when properly grounded at the service entrance. R/C (QIMS2), Dynoraxx (E357716) photovoltaic bonding device cat. no. Dynobond is an optional component that may be used with this system. The Dynobond device has been evaluated to provide module to module bonding. The Dynobond device attaches to the frame flange of adjacent modules

Listed (QIMS), SnapNrack MLPE Frame Attachment Kit model 242-02151 has been investigated to bond approved MLPE device back plates to frames of modules.

**See Appendix A for all tested MLPE devices.**

When installing the MLPEs per the specifications in the MLPE Installation section of this manual, the system is bonded to the optimizer backing plate.

## **Fire**

TopSpeed Universal has been investigated for a Class A System Fire Classification for a Steep-Sloped Roof with Type 1, Type 2, and Type 29 modules. Because the system was tested at 5 inches above the test roof fixture TopSpeed Universal can be installed without any height restrictions due to System Fire Classification. See Appendix A for potential module-specific height restrictions due to module temperature. The SkirtRail is considered an optional component with respect to Fire Classification, as TopSpeed Universal maintains the same Fire Classification Rating both with and without the SkirtRail.

SnapNrack recommends a periodic re-inspection of the completed installation for loose components, loose fasteners, and any corrosion, such that if found, the affected components are to be immediately replaced.

## **Water Submersion Test**

SnapNrack SpeedSeal™ Track has been evaluated for water penetration of composition shingle roofing systems by static water pressure head. Test method and apparatus were based on a version of ASTM Designation: E2140

## **Wind-Driven Rain Test**

Only the following components have been evaluated for the Wind-Driven Rain Test per UL Subject 2582:

SpeedSeal™ Track, SpeedSeal™ DeckTrack, Comp Flashing, Composition Umbrella Flashing, Flash Track, Umbrella Bolt. Testing was conducted without roofing sealant and without the Umbrella Bolt Gasket.

## TopSpeed Universal Structural Components



### Composition Flash Track

SnapNrack Composition Flash Track to be installed with Composition Flashing and Umbrella Lag



### Umbrella Lag

SnapNrack Umbrella Lag with Umbrella Sealing technology, assembly includes 5/16" Lag screw with EPDM gasket and Umbrella washer



### Composition Flashing

SnapNrack Composition Flashing



### SpeedSeal™ Track

SnapNrack SpeedSeal™ Track with advanced sealing technology, assembly includes SpeedSeal™ Track and foam Sealant Dam



### 5/16" Lag Screw with Sealing Washer

SnapNrack 5/16" Lag with Sealing Washer assembly including standard 5/16" lag screw and sealing washer

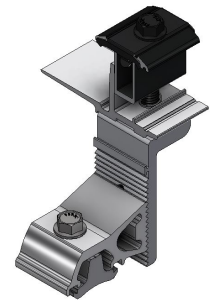

### Mount

SnapNrack TopSpeed Universal Mount assembly including rock in Channel Nut, Riser, Leveler, Mount clamp, and spring



### SpeedSeal™ DeckTrack

SnapNrack SpeedSeal™ DeckTrack with advanced sealing technology, assembly includes SpeedSeal™ DeckTrack and Sealing Ring



### #14 Sealing Wood Screw

SnapNrack #14 Sealing Wood Screw for deck mounting, features 1/2" Hex Head for single tool installations. Includes Stainless Steel Sealing Washer

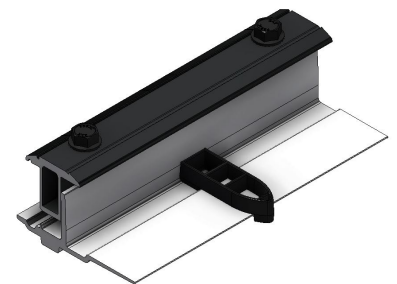

### Link

SnapNrack Universal Link assembly including Link bottom, Link top, Link column spacer, and springs

## TopSpeed Universal Structural Components



**AlphaTrack**

SnapNrack AlphaTrack with pre-applied butyl sealing technology, assembly includes AlphaTrack and Sealant. Installs with DeckAnchors™ or standard 5/16" Sealing Lag Screw



**DeckAnchor™**

SnapNrack proprietary DeckAnchor™, optimized for deck mounting, provides enhanced withdrawal and pullover resistance compared to standard wood screws. Includes Stainless Steel Sealing Washer



**DeltaTrack**

SnapNrack DeltaTrack with pre-applied butyl sealing technology, assembly includes DeltaTrack and Sealant. Installs with #14 Sealing Wood Screws



**SkirtRail**

SnapNrack TopSpeed Universal SkirtRail in double portrait or single landscape lengths

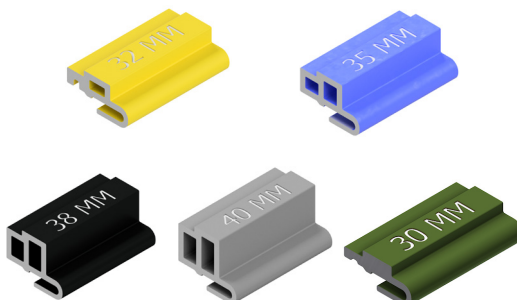

**SkirtRail Spacers**

SnapNrack TopSpeed Universal SkirtRail Spacer for 40mm, 38mm, 35mm, 32mm, and 30mm modules.

## Wire Managements Components

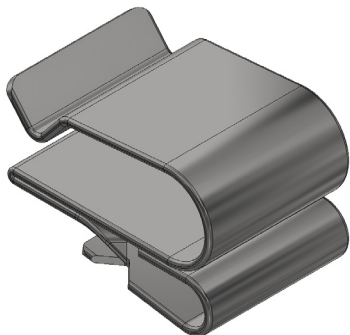

**Smart Clip**

Module frame cable clip, holds two PV wires or Enphase IQ-Cables

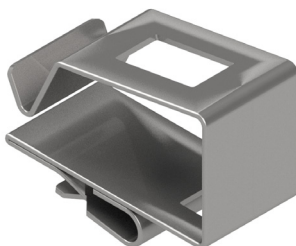

**Smart Clip XL**

Module frame cable clip, holds six PV wires or four Enphase IQ-Cable

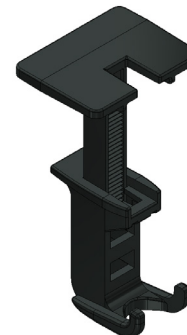

**Wire Saver**

Designed to secure conductors that become loose and hang below the array, holds one conductor

## Grounding/MLPE Components



### **OmniLug**

OmniLug including channel nut, OmniLug Bracket, and SEMS bolt with toothed washer.

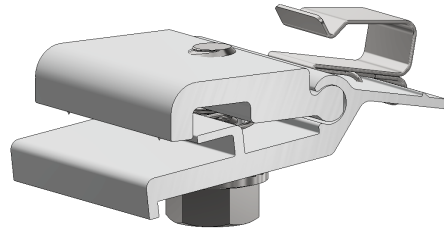

### **MLPE Frame Attachment Kit**

Attaches MLPEs (Module Level Performance Enhancers) and other related equipment to the module frame.



## Hardware Torque Specifications

The recommended torque to be applied to components for proper assembly and bonding are as follows:

Hardware Description	Torque Specification
TopSpeed Universal ½” bolts; System Leveling Bolt, Drop In/Rock In Channel Nut, Mount Top-Down Clamp, Link Top-Down Clamp	12 ft-lb
Ground Lug model 242-92202 to Flash Track, SpeedSeal™ Track, Ridge Mount Track or Module Frame, and Ground Lug model 242-92202 to Grounding Electrode Conductor (6-12 AWG Sol. Cu)	8 ft-lb
OmniLug model 242-10034 to Flash Track, SpeedSeal™ Track, AlphaTrack, or DeltaTrack (6-12 AWG Sol. Cu, or 8-10 AWG Str. Cu)	130 in-lb (10.8 ft-lb)
MLPE Frame Attachment Kit, MLPE Rail Attachment Kit	10 ft-lb
SolarEdge Frame Mounted Microinverter Bracket to Module Frame	11 ft-lb
Enphase Frame Mounted Microinverter Bracket to Module Frame	13 ft-lb
Ground Lug model SGB-4 to module or Flash Track	75 in-lb
Ground Lug model SGB-4 to module, Flash Track or SpeedSeal™ Track	75 in-lb
Ground Lug model SGB-4 to Grounding Electrode Conductor (4-14 AWG Sol. or Str. Cu)	35 in-lb
Ground Lug model GBL-4DBT to module	35 in-lb
Ground Lug model GBL-4DBT to Grounding Electrode Conductor (10-14 AWG Sol. or Str. Cu)	20 in-lb
Ground Lug model GBL-4DBT to Grounding Electrode Conductor (8 AWG Sol. or Str. Cu)	25 in-lb
Ground Lug model GBL-4DBT to Grounding Electrode Conductor (4-6 AWG Sol. or Str. Cu)	35 in-lb
OmniLug model 242-10034 as an MLPE mount, to Flash Track, SpeedSeal™ Track, AlphaTrack, or DeltaTrack	130 in-lb (10.8 ft-lb)

## Site Survey

- Measure the roof surfaces and develop an accurate drawing, including any obstacles such as chimneys and roof vents.
- If plans for the roof structure are available, verify that the plans match the final structure.
- Identify any roof access or setback areas as required by the local AHJ.
- Identify any construction issues that may complicate the process of locating rafters from the roof surface.
- If you find structural problems such as termite damage or cracked rafters that may compromise the structure's integrity consult a structural engineer.

## Design Guidance

- PV Designers should account for the 0.75 inch spacing between rows and columns of modules when creating the layout.
- Ridge Mounts are required if modules will be installed with the top edge of the modules less than 12 inches from the ridge peak.
- Draw the rafter location on the layout to identify where roof attachments can be installed.
- Determine site conditions for calculating the engineering values, confirm site conditions and code versions comply with local AHJ requirements.
- Reference site conditions and system specifications in TopSpeed Universal Structural Engineering Report to determine maximum attachment spacing and cantilever values
- Draw roof attachment locations on layout based on maximum attachment spacing and cantilever values



### Design Recommendation:

Four roof attachments per module are recommended for at least one module per row to provide rigidity in the array.

- Staggering rows of attachments on alternating rafters is acceptable, and may provide more evenly distributed loads on the roof structure.
- Identify homerun and Junction Box locations based on rooftop wiring requirements.
- Mark distance from array edge to identifiable roof feature in x and y axes.
- Mark distance from array edge to identifiable roof feature in x and y axes.
- Insert SnapNrack installation details into design plan set specific to the project requirements.

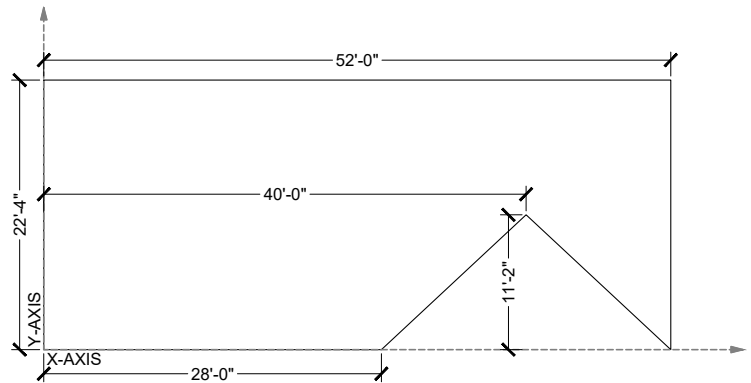
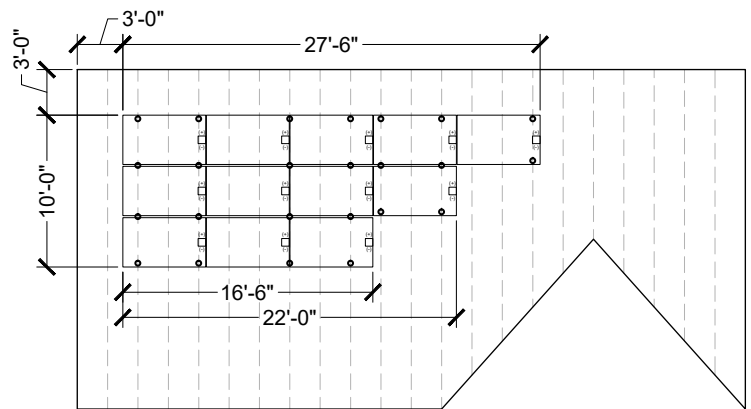

Image note: X-Axis described in this manual is cross-slope on the roof, Y-Axis is in line with the roof slope.



### Safety Guidance

- Always wear appropriate OSHA approved safety equipment when at active construction site.
- Appropriate fall protection or prevention gear should be used. Always use extreme caution when near the edge of a roof.
- Use appropriate ladder safety equipment when accessing the roof from ground level.
- Safety equipment should be checked periodically for wear and quality issues.
- Always wear proper eye protection when required.

## Required Tools

- Roof Marking Crayon or Chalk
- Tape Measure
- Prybar\*

\*Not required for SpeedSeal™ Track, SpeedSeal™ DeckTrack, AlphaTrack or DeltaTrack

## LAYOUT INSTRUCTIONS

1) Transfer the layout to the roof using marking crayon or chalk and identify the outside corners of the array. Draw attachment locations on the roof positioned in the x-axis to land on a rafter and in the y-axis to land between modules rows.

2) **(For Flash Track installation only)** Use a prybar to loosen layers of composition above proposed attachment locations in preparation for proper flashing placement

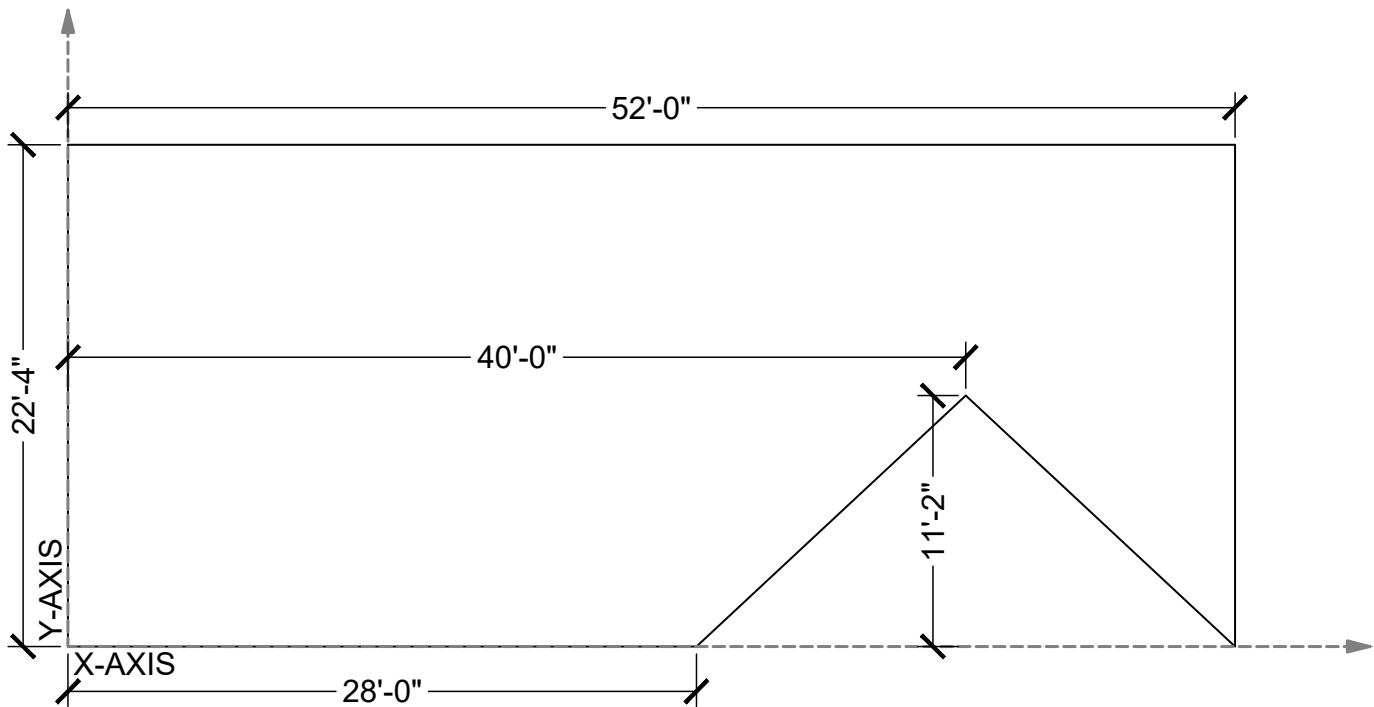

 **Layout Note:** Ensure the final roof attachment locations do not exceed the maximum attachment spacing and cantilever specified in the design plan

## Required Tools

- Hammer or Stud Finder
- Roof Marking Crayon or Chalk
- Drill with 3/16" Drill Bit
- Roof Sealant
- Socket Wrench
- Torque Wrench
- 1/2" Socket
- Pry Bar\*

\*Not required for SpeedSeal™ Track, SpeedSeal™ DeckTrack, AlphaTrack or DeltaTrack

## Materials Included - Flash Track & Composition Flashing

- 1 (1) SnapNrack Composition Flashing
- 2 (1) SnapNrack Flash Track
- 3 (1) SnapNrack 5/16" SS Umbrella Lag Screw

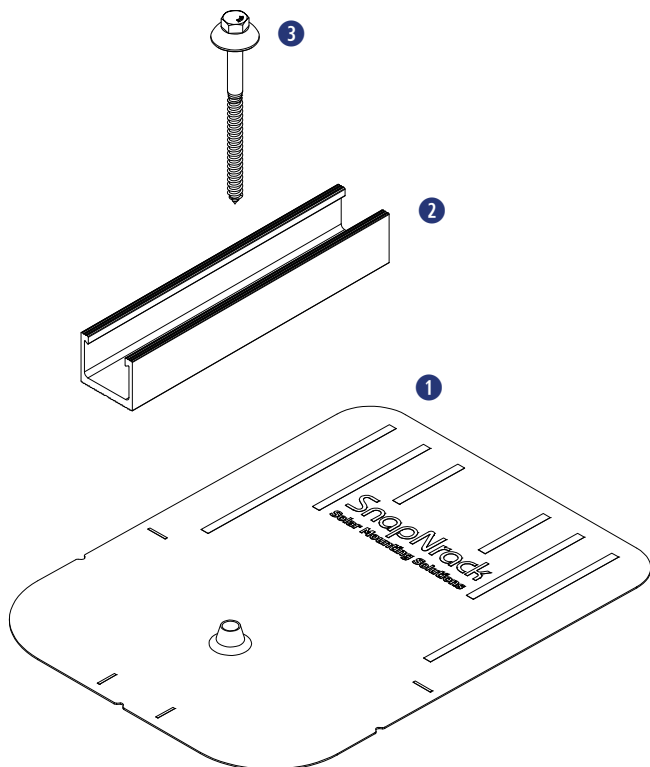

## Materials Included - SpeedSeal™ Track

- 1 (1) SnapNrack SpeedSeal™ Track Sealing Base
- 2 (1) 5/16" SS Lag Screw
- 3 (1) 5/16" SS Washer (Sealing Washer is recommended)

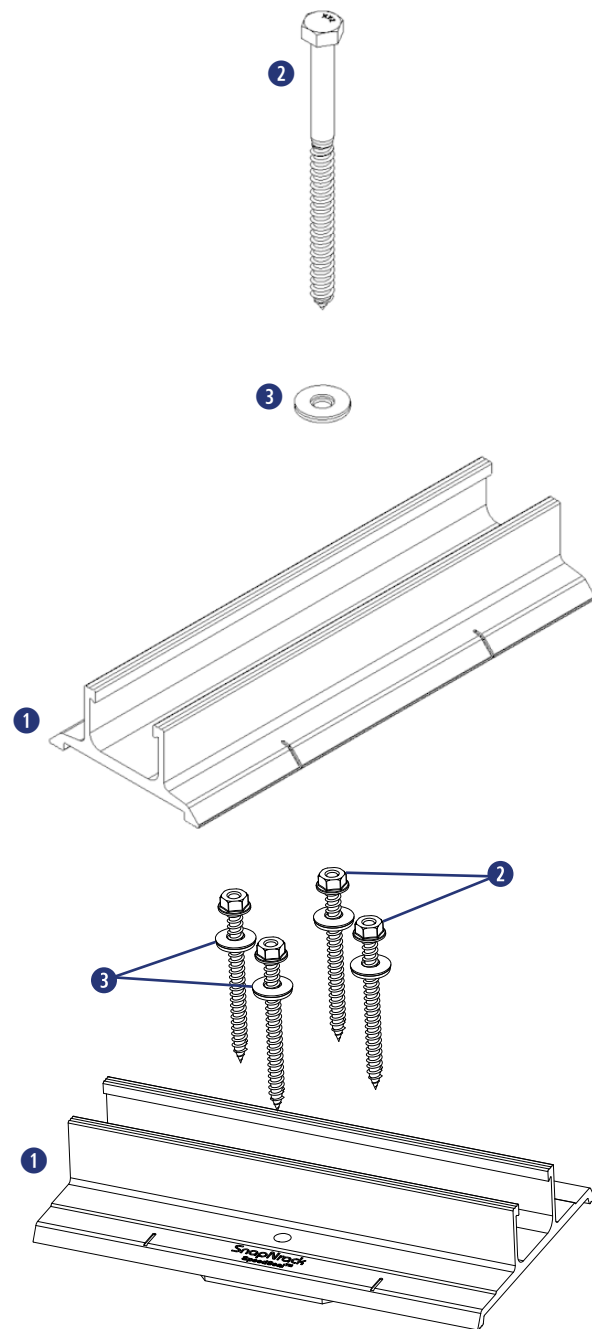

## Materials Included - SpeedSeal™ DeckTrack

- 1 (1) SnapNrack SpeedSeal™ DeckTrack Sealing Base
- 2 (4) 1/4" x 20 SS Screw
- 3 (4) 1/4" SS Washer (Sealing Washer is recommended)

## Required Tools

● Roof Marking Crayon or Chalk

● 1/2" Socket

\*Required when rafter mounting

● Socket Wrench

● Hammer or Stud Finder\*

● Torque Wrench

● Drill with 3/16" Drill Bit\*

## Materials Included - AlphaTrack

① (1) SnapNrack AlphaTrack with Butyl pad

② (2) SnapNrack DeckAnchors

③ (2) 3/8" Stainless Steel Sealing Washers

### Rafter Mount

① (1) 5/16" Lag Screw (2 1/2" Minimum Embedment)

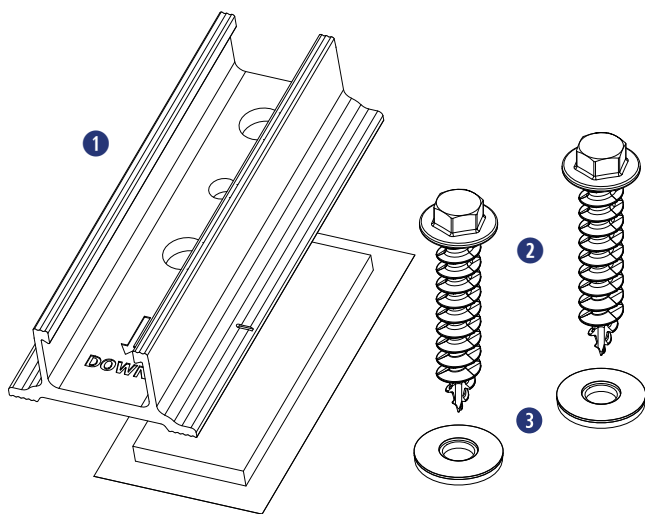

## Materials Included - DeltaTrack

① (1) SnapNrack DeltaTrack with Butyl pad

② (4) #14" Stainless Steel Wood Screws

③ (4) 1/4" Stainless Steel Sealing Washers

### Rafter Mount

① (2) #14 Wood Screws (2 1/2" Minimum Embedment)

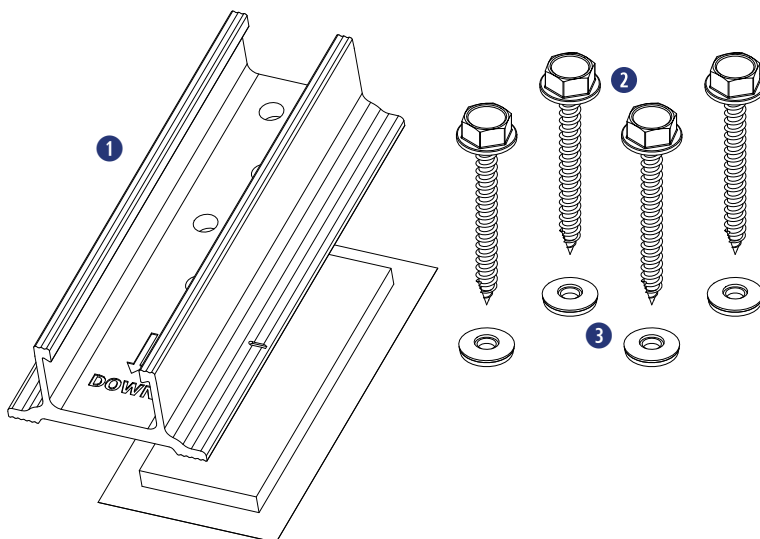

### ⚙️ Application Note:

Compatible roofing substrates and minimum roof pitches:  
Composition shingle- 9.5°

Low slope roofs including metal, concrete, rolled composition, EPDM, TPO, PVC, PolyPropylene, and SMS modified bitumen- ensure positive drainage with no chance of standing water. Ensure roof construction and pitch meet minimum building code requirements.

Temperature Range:

Installation: 0°F - 150°F (-18°C - 66°C)

Service: -40°F - 200°F (-40°C - 93°C)

For installation temperatures below 32°F (0°C) it is recommended that the butyl is warmed to more easily conform to the roof texture.

## INSTALLATION INSTRUCTIONS - FLASH TRACK & COMPOSITION FLASHING

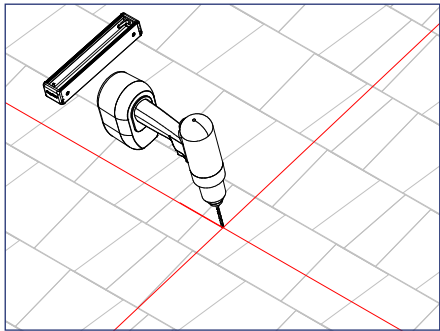

1) Using a Flash Track as a template, drill a pilot hole into the rafter with 3/16" drill bit.

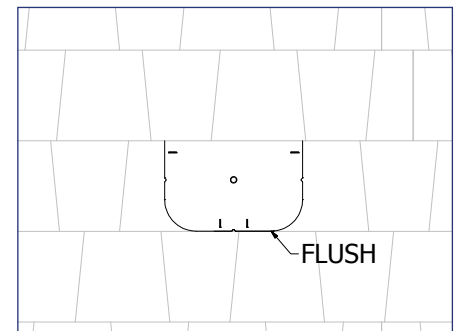
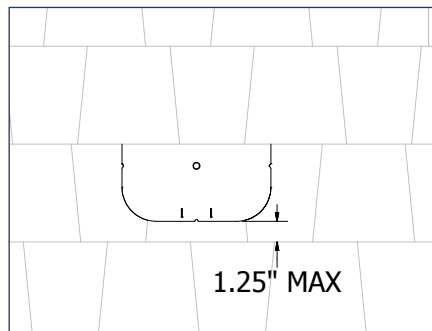
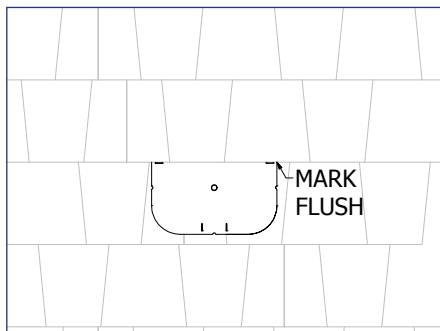

### Install Note:

Composition Flashings should be installed in the nominal position; It is acceptable to install the flashing with leading edge of flashing 1-1/4" above the leading edge of first course of composition, or flush with the leading edge of the first course of composition. Marks on flashing edge are a guide and may be used to simplify installation. Align oveTopSpeedapping composition leading edge with marks.

2) Apply roofing manufacturer's approved sealant to lag screw, apply sealant in a circle around pilot hole and fill pilot hole with sealant.

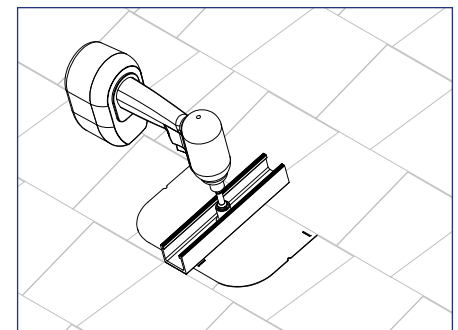
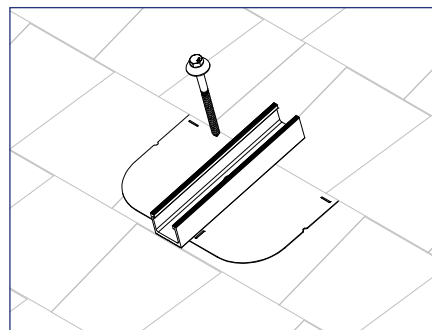
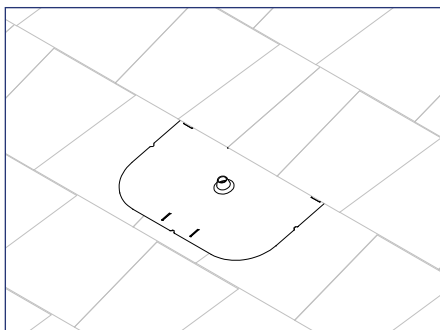

3) Install flashing underneath shingle course directly above pilot hole, align hole in flashing with pilot hole.

4) Place Flash Track over hole in flashing, drive Umbrella Lag through hole in Flash Track, flashing, and into pilot hole for minimum 2.5" embedment in rafter

### Install Note:

Ensure flashing extends minimum (2) courses above base.

Best Practice: Apply a U-shape of sealant on top portion of flashing underside.

## INSTALLATION INSTRUCTIONS - SPEEDSEAL™ TRACK

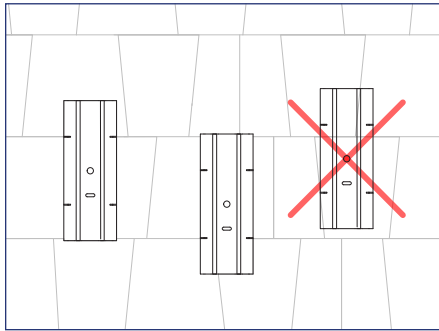

1) Position SpeedSeal™ Track. Tracks must be positioned with the portion between the lines entirely on one course of composition.

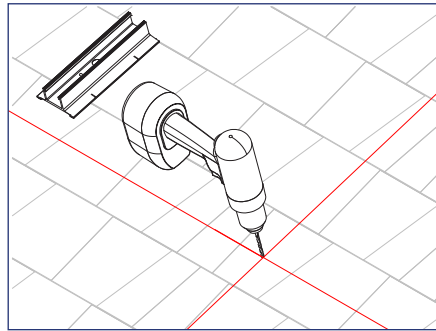

2) Using a SpeedSeal™ Track as a template, drill a pilot hole into the rafter with 3/16" drill bit

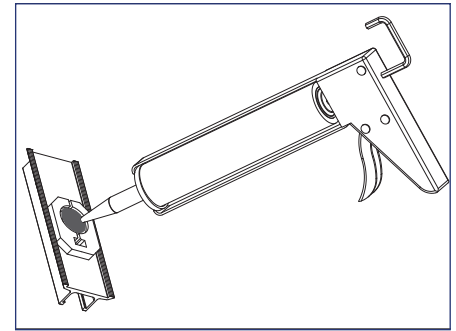

3) Turn SpeedSeal™ Track over and fill circular portion of dam created by foam with roof sealant

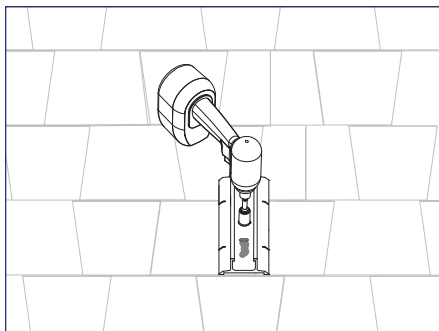

4) Attach SpeedSeal™ Track to roof using a 5/16" SS lag screw and washer.

### Install Note:

Roof sealant should be expelled from the vent of the SpeedSeal™ Track as it is installed to assure the proper amount of roof sealant has been applied. If no sealant is expelled, remove SpeedSeal™ Track and add more sealant to the cavity then reinstall on roof.

## INSTALLATION INSTRUCTIONS - SPEEDSEAL™ DECKTRACK FOR RAFTER & ROOF DECKING

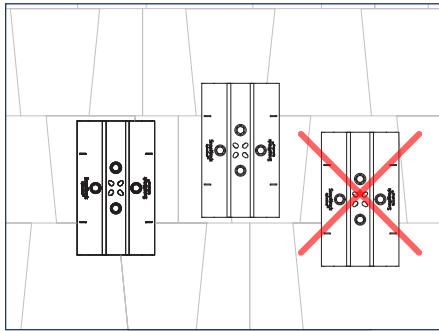

1) Position SpeedSeal™ DeckTrack. DeckTracks must be positioned with the portion between the lines entirely on one course of composition.

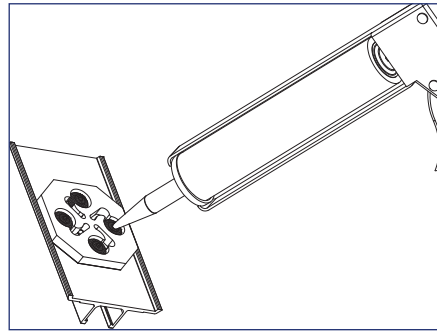

2) Fill all four cavities on bottom of SpeedSeal™ DeckTrack created by foam sealant gasket with roof sealant to ensure a watertight seal.

### Install Note:

Fill any seam in shingles within 4" of a deck screw with sealant prior to installing SpeedSeal™ DeckTrack.

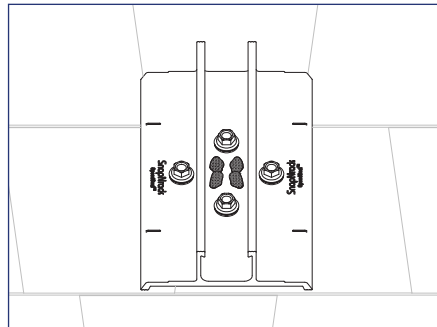
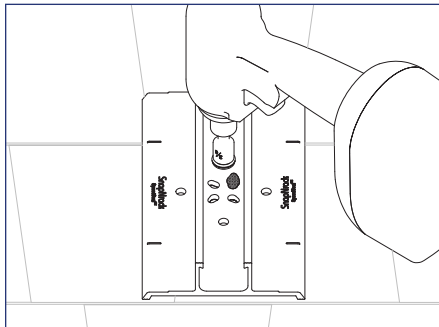

3) Attach SpeedSeal™ DeckTrack to roof using four (4) ¼" x 2½" SS lag screws and washers.

### Install Note:

Roof sealant should be expelled from all four vents of the SpeedSeal™ DeckTrack as it is installed to assure the proper amount of roof sealant has been applied. If sealant is not expelled from all four vents, remove SpeedSeal™ DeckTrack and add more sealant to the cavity then reinstall on roof.

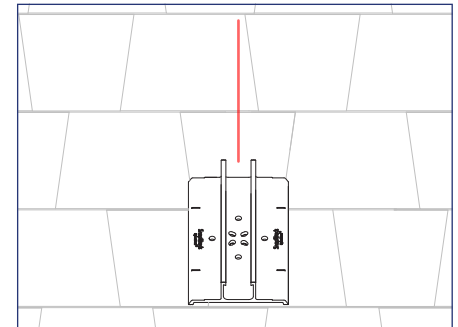

4) **Optional Rafter attachment step:** After locating and marking rafters on the roof use four (4) ¼" x 2½" SS lag screws and washers to attach the DeckTrack to rafters and decking by following steps 1-3 above. The two lag screws in the center of the DeckTrack must be embedded into the rafter.



## INSTALLATION INSTRUCTIONS - ALPHATRACK™ TO DECK

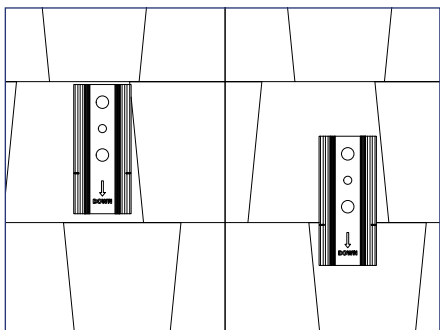

1) Using roof attachment locations drawn during system layout, determine position of AlphaTrack for proper alignment on shingle course.

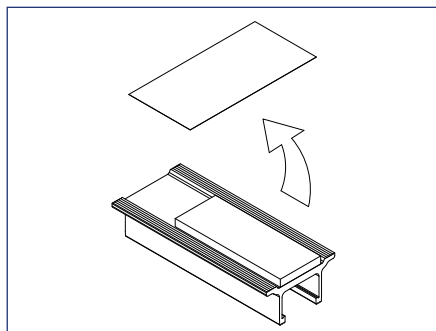

2) Remove paper from the bottom of the AlphaTrack to expose the layer of butyl and place on roof at desired location.

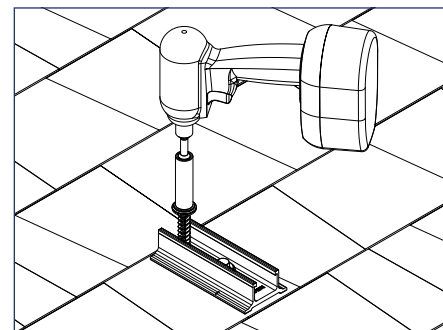

3) Insert first DeckAnchor™ screw through large AlphaTrack mounting hole and drive into roof, then repeat for the remaining DeckAnchor™ screw through other large mounting hole.

### ⚙️ Install Note:

- Track must be installed with “down” arrow pointing down the roof.
- Butyl on track must only contact a single shingle course, and not extend onto shingle course above or below.
- Fill any seam in shingles within 4” of a fastener with sealant prior to installing track.

### ⚙️ Best Practice:

AlphaTrack should be installed only on dry, clean surfaces. Remove any moisture, dirt, or debris from roof surface before AlphaTrack is installed.

### ⚙️ Best Practice:

Tighten fasteners until butyl starts squeezing out from all sides of the Track.

## INSTALLATION INSTRUCTIONS - ALPHATRACK™ TO RAFTER

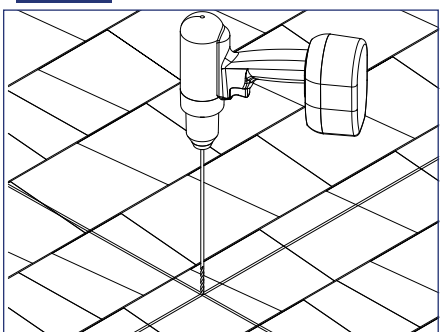

1) Using roof attachment locations drawn during system layout, determine position of AlphaTrack for proper alignment on shingle course and drill pilot hole at location of small center mounting hole.

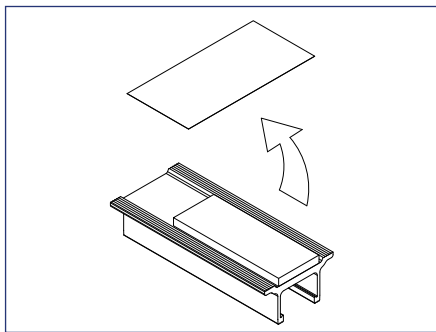

2) Remove paper from the bottom of the AlphaTrack to expose the layer of butyl and place on roof at desired location.

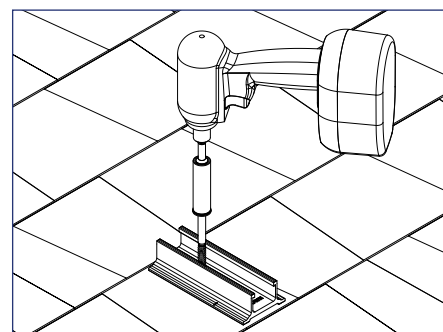

3) Insert lag screw through small AlphaTrack mounting hole and drive into rafter.

### ⚙️ Install Note:

- Track must be installed with “down” arrow pointing down the roof.
- Butyl on track must only contact a single shingle course, and not extend onto shingle course above or below.
- Fill any seam in shingles within 4” of a fastener with sealant prior to installing track.

### ⚙️ Best Practice:

AlphaTrack should be installed only on dry, clean surfaces. Remove any moisture, dirt, or debris from roof surface before AlphaTrack is installed.

### ⚙️ Best Practice:

Tighten fasteners until butyl starts squeezing out from all sides of the Track.

## INSTALLATION INSTRUCTIONS - DELTATRACK™ TO DECK

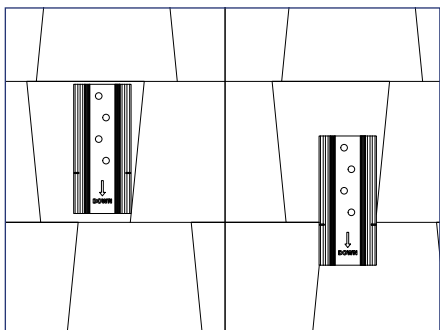

1) Using roof attachment locations drawn during system layout, determine position of DeltaTrack for proper alignment on shingle course.

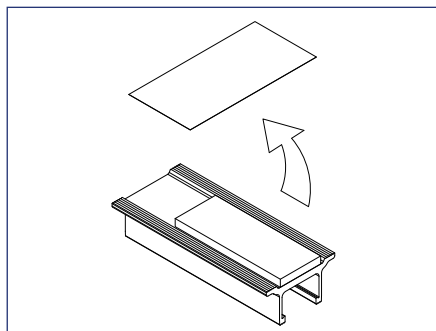

2) Remove paper from the bottom of the DeltaTrack to expose the layer of butyl and place on roof at desired location.

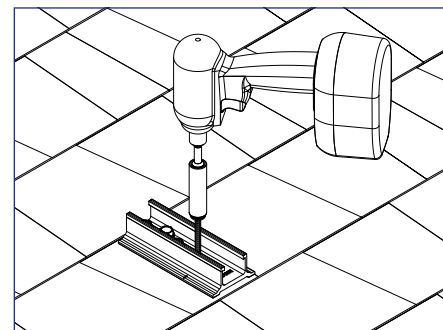

3) Insert (4) wood screws through DeltaTrack mounting holes and drive into the roof.

### Install Note:

- Track must be installed with “down” arrow pointing down the roof.
- Butyl on track must only contact a single shingle course, and not extend onto shingle course above or below.
- Fill any seam in shingles within 4” of a fastener with sealant prior to installing track.

### Best Practice:

DeltaTrack should be installed only on dry, clean surfaces. Remove any moisture, dirt, or debris from roof surface before AlphaTrack is installed.

### Best Practice:

Tighten fasteners until butyl starts squeezing out from all sides of the Track.

## INSTALLATION INSTRUCTIONS - DELTATRACK™ TO RAFTER

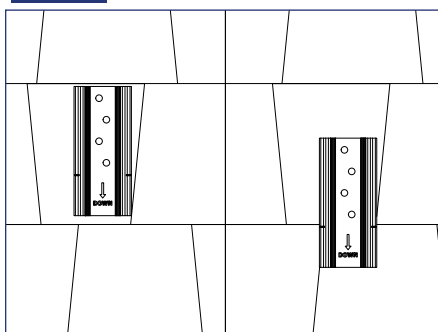

1) Using roof attachment locations drawn during system layout, determine position of DeltaTrack for proper alignment on shingle course.

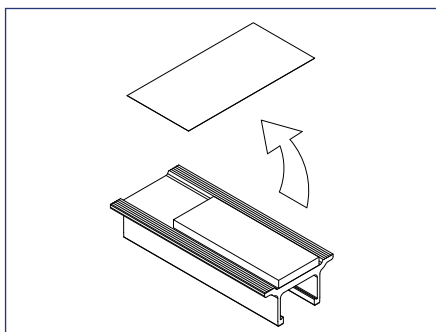

2) Remove paper from the bottom of the DeltaTrack to expose the layer of butyl and place on roof at desired location.

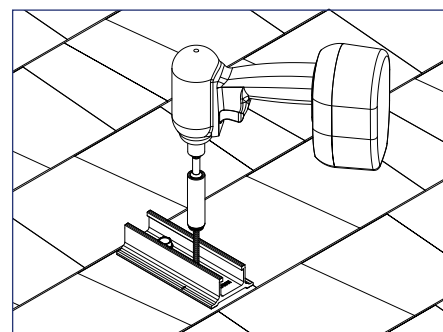

3) Insert (2) wood screws through outer DeltaTrack mounting holes and drive into rafter..

### Install Note:

- Track must be installed with “down” arrow pointing down the roof.
- Butyl on track must only contact a single shingle course, and not extend onto shingle course above or below.
- Fill any seam in shingles within 4” of a fastener with sealant prior to installing track.

### Best Practice:

DeltaTrack should be installed only on dry, clean surfaces. Remove any moisture, dirt, or debris from roof surface before AlphaTrack is installed.

### Best Practice:

Tighten fasteners until butyl starts squeezing out from all sides of the Track.

## Required Tools

- Socket Wrench
- Torque Wrench
- 1/2" Socket
- String Line

## Materials Included - TopSpeed Universal Mount

- ① (1) TopSpeed Universal Mount
- ② (1) TopSpeed Universal Link
- ③ (1) TopSpeed Universal SkirtRail
- ④ (1) TopSpeed Universal SkirtRail Spacers

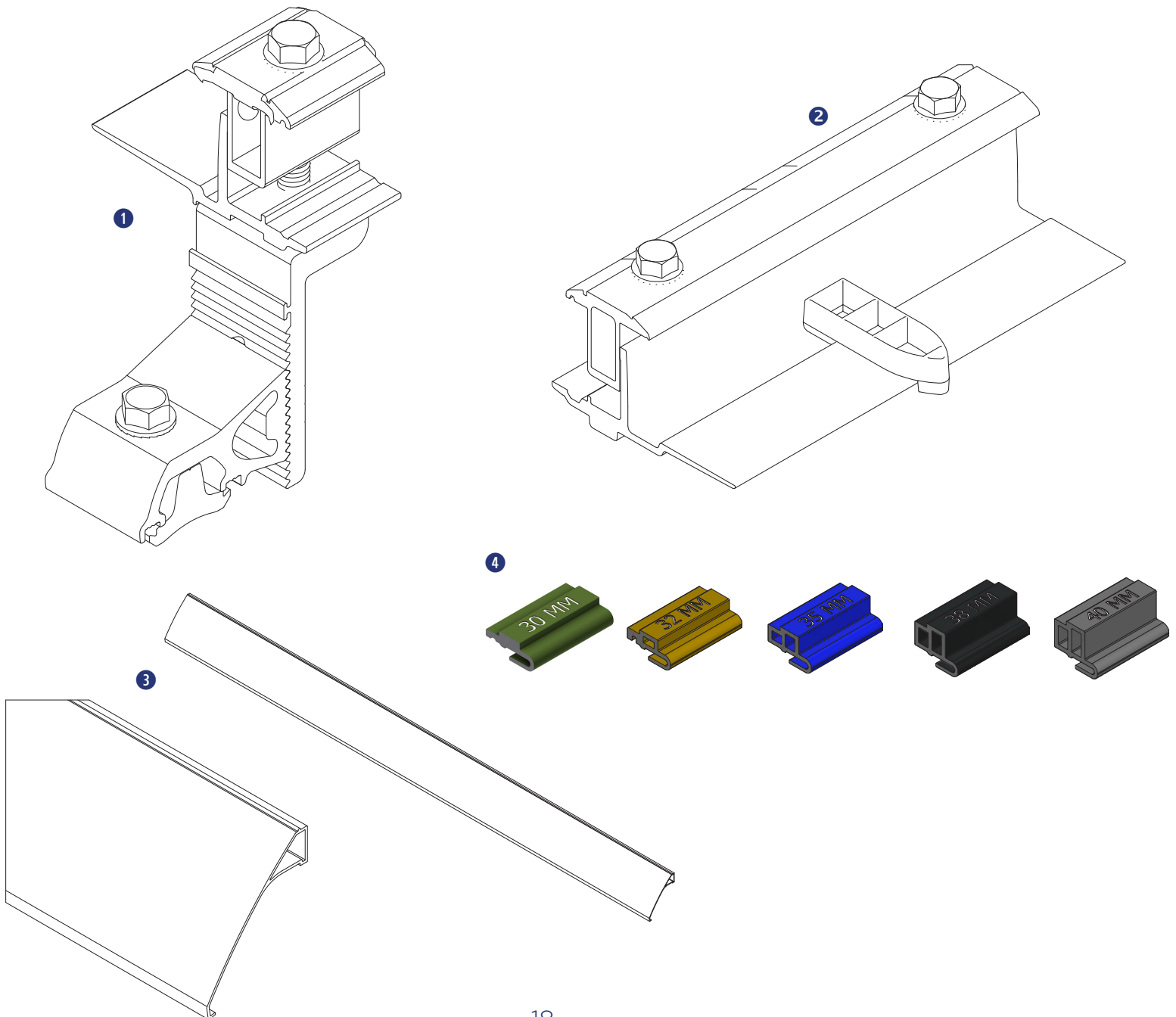

## INSTALLATION INSTRUCTIONS

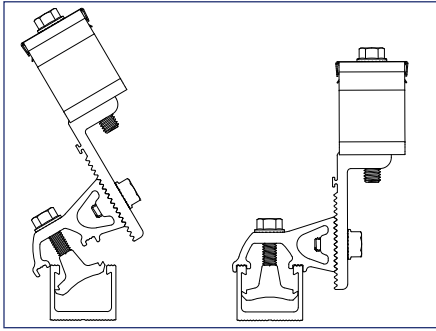

1) Install the front row of Mounts by rocking the channel nut on bottom of TopSpeed Universal Mount into Flash Track, or SpeedSeal™ Track.

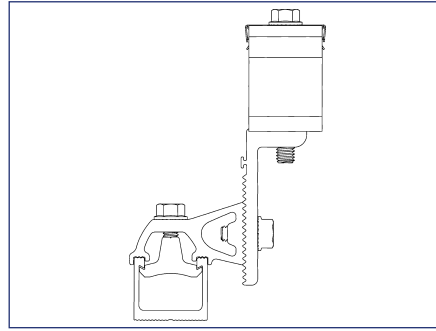

2) Partially tighten Riser bolt to seat the channel nut into the Flash Track, or SpeedSeal™ Track.

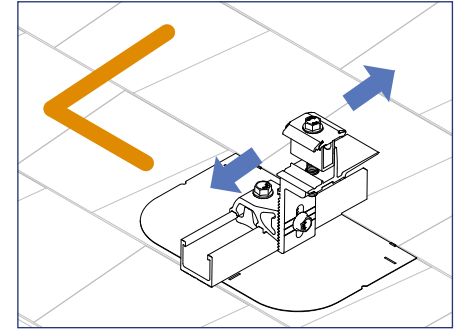

3) Slide the bottom two corner Mounts up or down in the SpeedSeal™ Track, or Flash Track until aligned with the bottom edge of array as marked on the roof, then tighten the Riser bolt.

### Install Note:

Mounts can be installed on either the left or right side of the Flash Track, or SpeedSeal™ Track to avoid any interference with Links

### Install Note:

Channel nuts must be fully engaged in track and must not extend beyond either end of the track

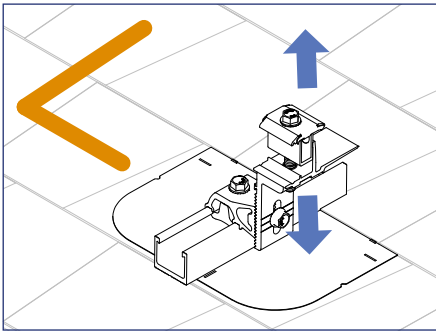

4) To set the TopSpeed Universal Mount level loosen the Leveler bolt and move the Leveler up or down, then tighten the Leveler bolt and torque to 12 ft-lb.

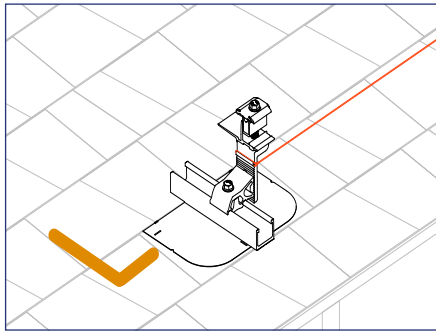

5) Run string line along bottom row to align and level TopSpeed Universal Mounts between the corner mounts

### Install Note:

Use the string line catch and alignment feature on Mounts to hold the string line in place to level and align the Mounts

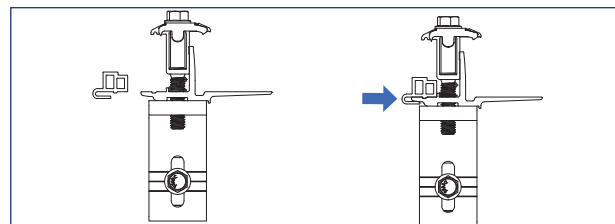
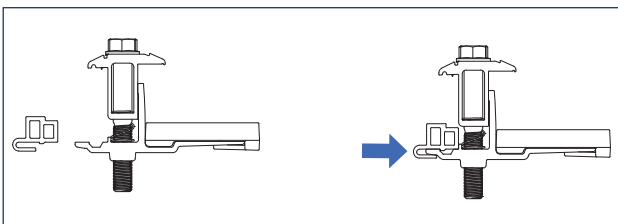

6) TopSpeed Universal Spacers will need to be added to Mounts and Links where SkirtRail will be installed

## INSTALLATION INSTRUCTIONS

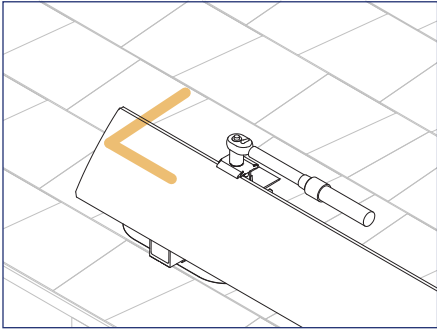

7) Install TopSpeed Universal SkirtRail by holding the SkirtRail in Mount, sliding SkirtRail to align with array layout marks, and clamping SkirtRail into mount

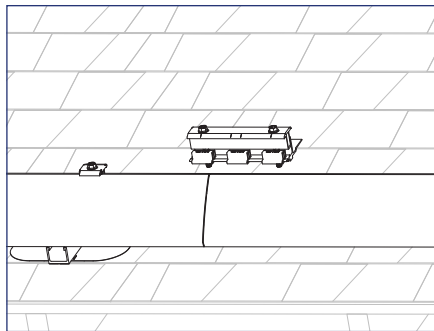

8) Use TopSpeed Universal Links to connect multiple lengths of Array SkirtRail

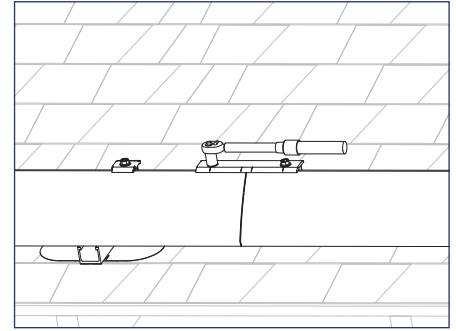

## Required Tools

- Socket Wrench
- Torque Wrench
- 1/2" Socket
- Electrician Tools

## Materials Included

### SnapNrack OmniLug (242-10034)

- ① (1) SnapNrack OmniLug Bracket
- ② (1) 5/16-18 x 1-1/4" Stainless Steel SEMS Bolt with Toothed Washer
- ③ (1) SnapNrack Channel Nut (bonding or non-bonding)

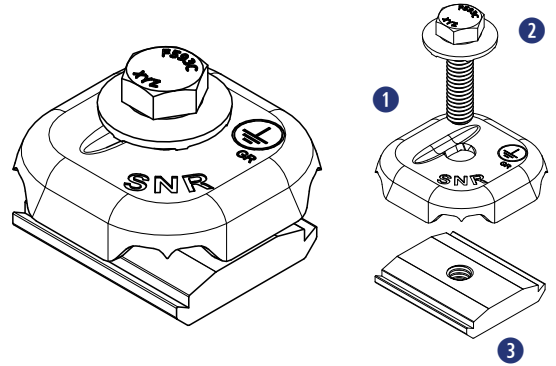

### SnapNrack Ground Lug (242-92202)

- ① SnapNrack Ground Lug TopSpeed PRC
- ② (2) Bolt Hex Cap, 5/16"- 18 X 3/4", SS

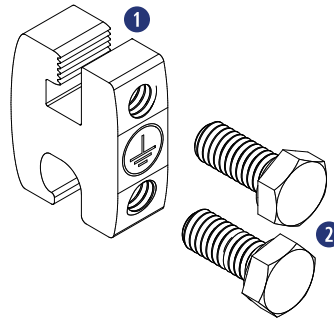

## Smart Clips

- ① (1) Smart Clip II (2) PV Wire, (1) Enphase IQ Cable
- ② (1) Smart Clip XL ((6) PV Wire, (4) Enphase IQ)
- ③ (1) Wire Saver ((1) PV Wire)

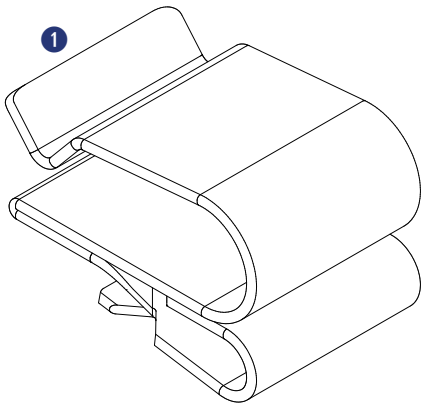

Smart Clip II

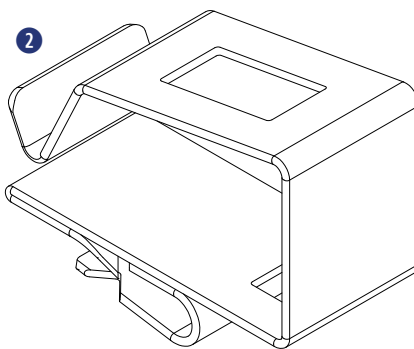

Smart Clip XL

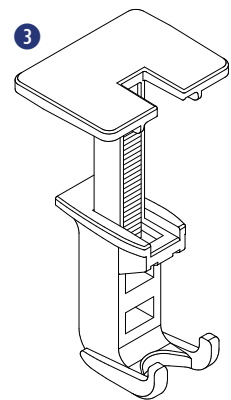

Wire Saver

## INSTALLATION INSTRUCTIONS - OmniLug

The OmniLug to be used in accordance with the National Electric Code, ANSI/NFPA 70.

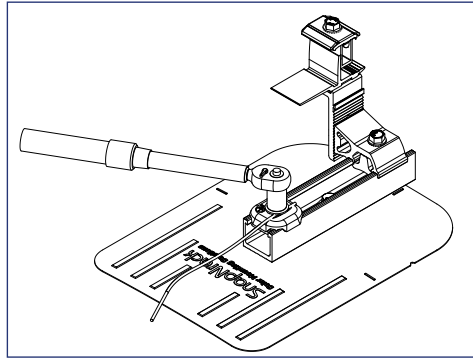
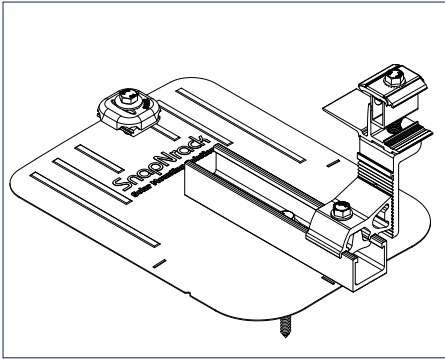

1) OmniLug can be attached to any Flash Track, or SpeedSeal™ Track near the Junction Box. Insert OmniLug into Flash Track, or SpeedSeal™ Track.

2) Run 10 - 6 AWG, solid, bare copper GEC into OmniLug channel, torque clamping bolt to 16 ft-lb

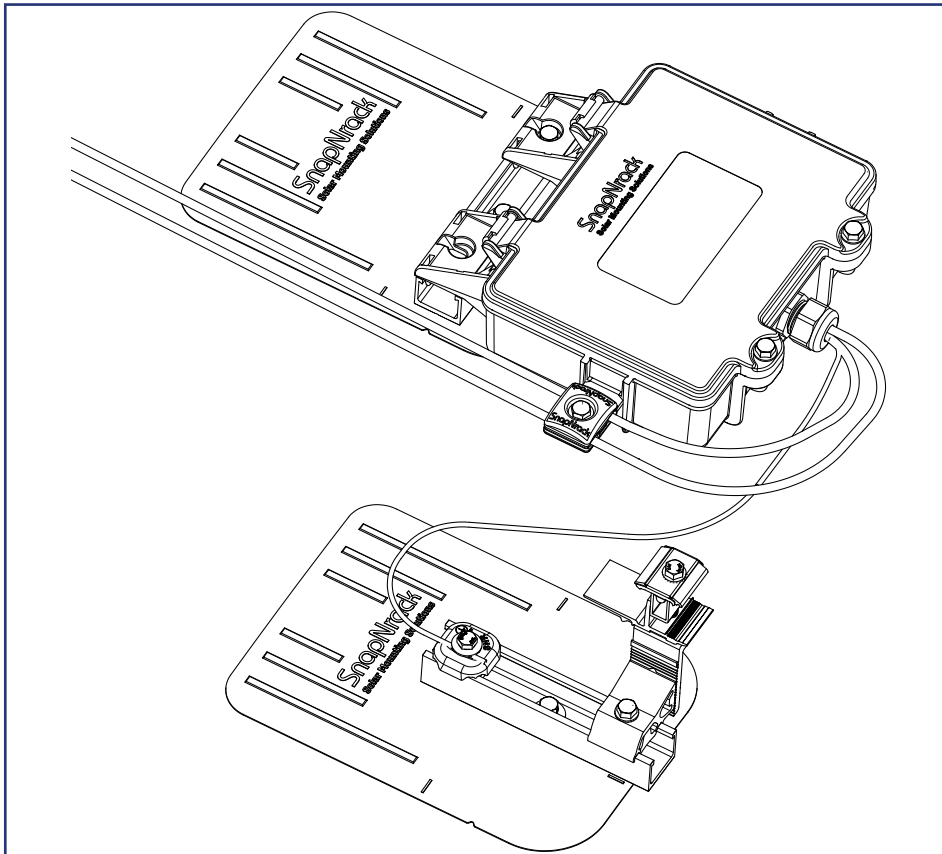

3) Run bare, solid EGC from OmniLug to Junction Box, bond bare EGC to stranded EGC in Junction Box. For details on installing the Junction Box reference the **RL Universal Junction Box Installation Manual**.

## INSTALLATION INSTRUCTIONS - SMART CLIPS

SmartClip and SmartClip XL should be used to route conductors in a neat and workmanlike manner away from all non-bonded components and support the conductors adequately to eliminate potential damage.

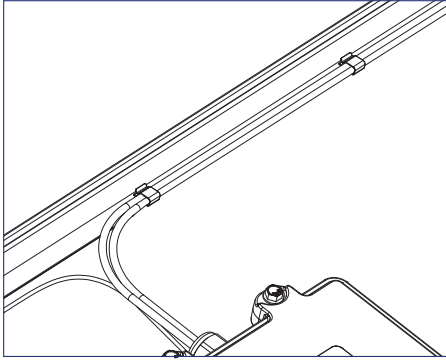

1) Use SnapNrack Smart Clip II to manage up two PV wires inside the module frame while prepping out the modules on the ground or installing modules on the roof.

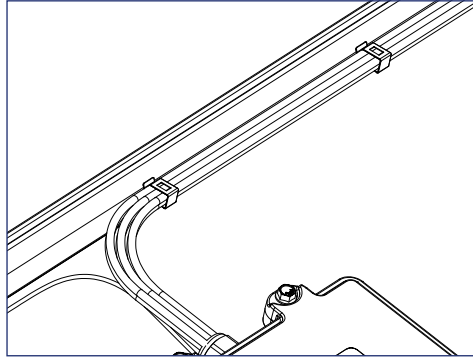

2) Use SnapNrack Smart Clip XL to manage larger bundles of PV wire; up to 6 PV wires per clip



## Required Tools

- Socket Wrench
- Torque Wrench
- 1/2" Socket

## Materials Included - MLPE Rail Attachment Kit

- ① (1) SnapNrack MLPE Frame Attachment Top
- ② (1) SnapNrack MLPE Frame Attachment Bottom
- ③ (1) 5/16"-18 X 3/4" Serrated Flange Bolt SS
- ④ (1) SnapNrack Smart Clip
- ⑤ (1) SnapNrack MLPE Frame Attachment Coil Spring SS

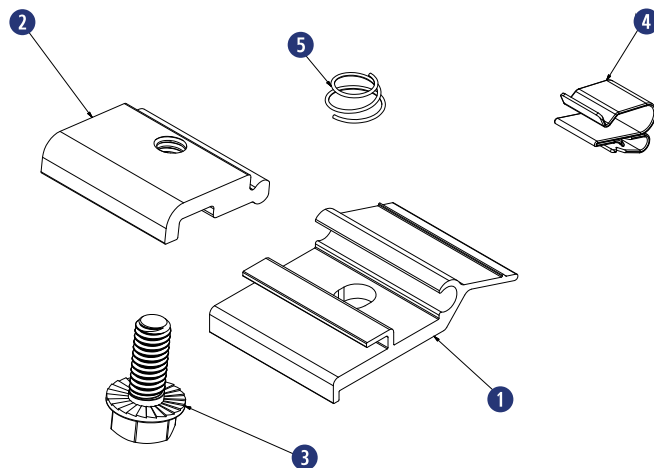
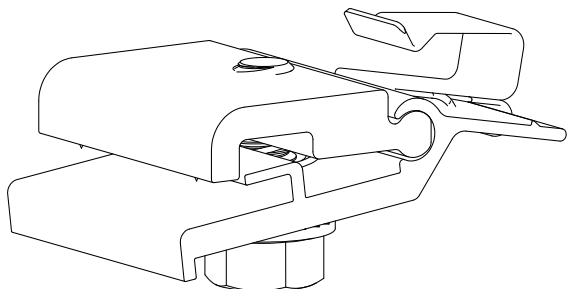

## Materials Included

### SolarEdge Frame Mount

- ① (1) SolarEdge Optimizer w/ Frame-Mounted Module Add-On

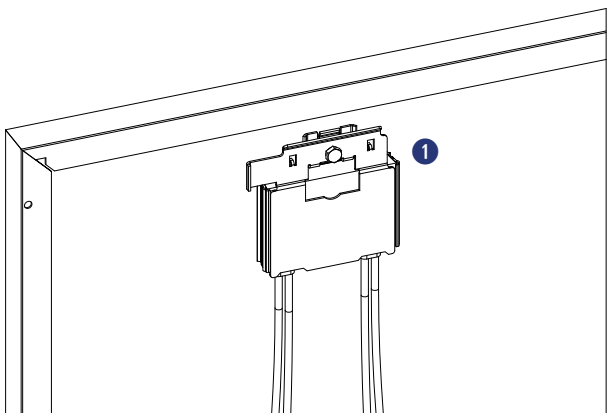

### Enphase Frame Mount

- ① (1) Enphase Microinverter
- ② (1) Enphase Frame Mount

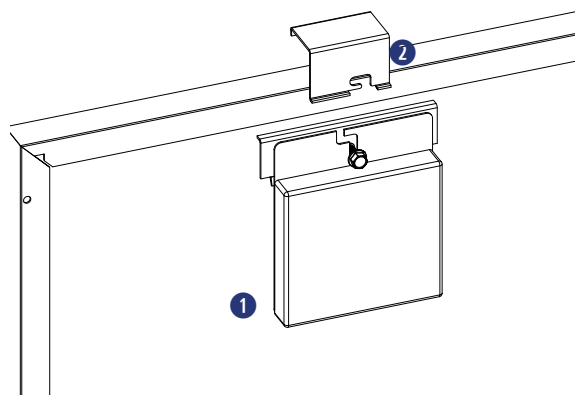

## INSTALLATION INSTRUCTIONS - SNAPNRACK MLPE FRAME ATTACHMENT KIT

SnapNrack MLPE Frame Attachment kit are used to attach module level performance enhancing devices, and other devices such as an SRD (rapid shutdown device), directly to module frames, and provide integrated grounding/bonding for Devices grounded through metal back plate. (Refer to the list of tested MLPE devices on page 4 of this manual)

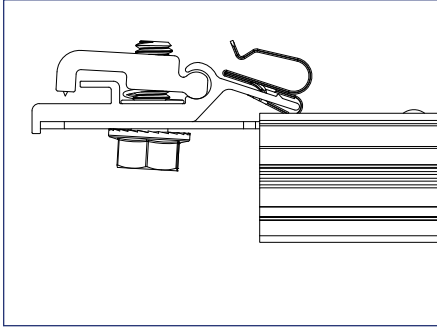

1) Slide the backplate channel of the MLPE device under the MLPE Frame Attachment Kit bolt. The MLPE mounting plate should rest against the MLPE mounting plate backstop on the MLPE Frame Attachment Kit

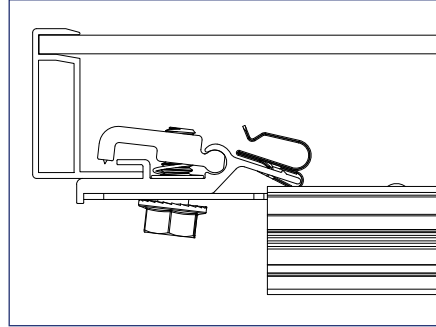

2) Position the MLPE Frame Attachment Kit on the module frame flange in a location that will not interfere with mounting system components. The module frame flange should rest against the module flange backstop on the MLPE Frame Attachment Kit.

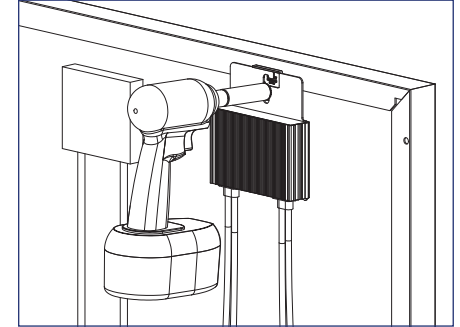

3) Tighten the mounting bolt on the MLPE Frame Attachment Kit to 10 lb-ft (120 lb-in).



### Install Note:

The MLPE Frame Attachment Kit bonds the following components:  
Module Frame, MLPE backplate and Smart Clip.



### Install Note:

Avoid blocking module frame drainage holes when installing the MLPE Frame Attachment Kit.

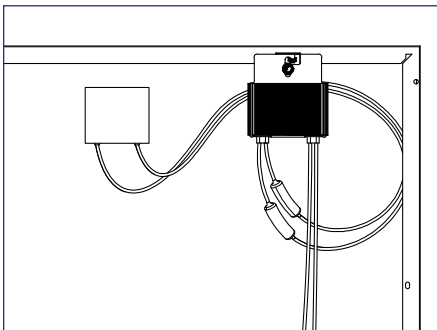

4) Connect the module leads to the input connectors on the MLPE device and manage conductors with the integrated Smart Clip.

## INSTALLATION INSTRUCTIONS - SOLAREGE FRAME MOUNT

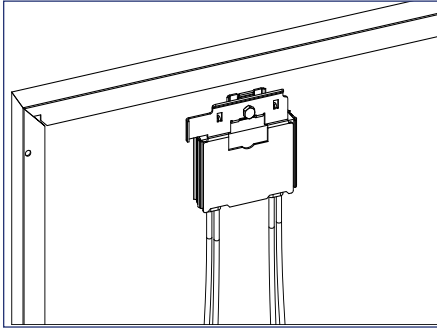

1) Locate the SolarEdge optimizer with Frame-Mounted Module Add-On at a location on the module frame that will not interfere with the TopSpeed Universal Mounts.

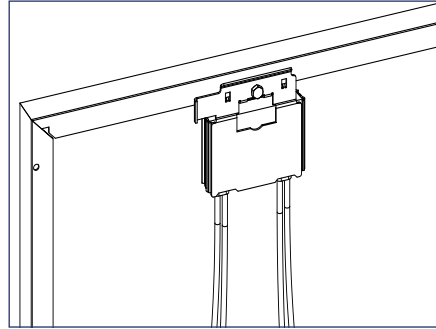

2) Install the optimizer mounting plate onto the module frame and tighten hardware to 11 ft-lbs.

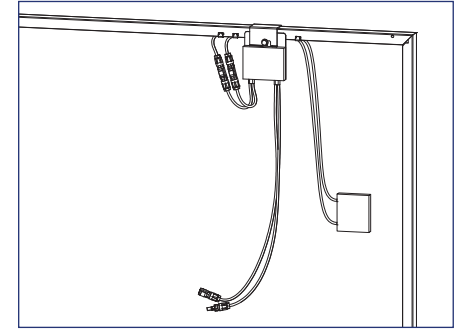

3) Connect the module leads to the input connectors on the optimizer and manage conductors with SnapNrack Smart Clips.



### Install Note:

If module is mounted in portrait, install MLPE on long side, short side for landscape.

## INSTALLATION INSTRUCTIONS - ENPHASE FRAME MOUNT

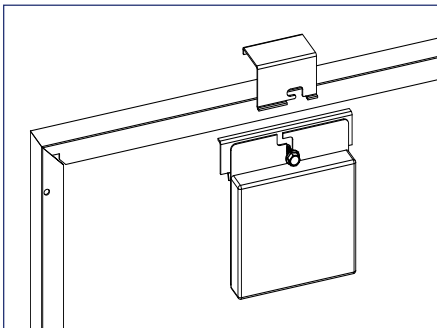

1) Locate the Enphase Frame Mount bracket clamp at a location on the module frame that will not interfere with the TopSpeed Universal Mounts.

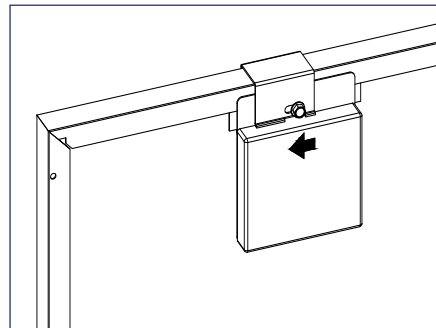

2) Slide the microinverter unit onto the bracket clamp, then move it slightly to the left.



### Install Note:

The microinverter mounting flange should be on the outside of the module frame.

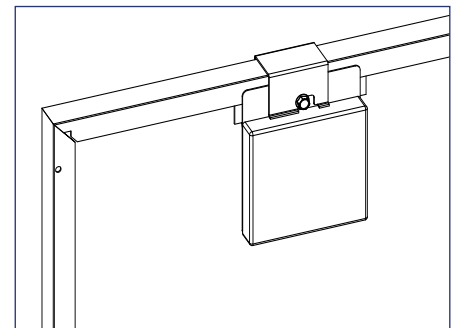

3) Tighten the hardware to 13 ft-lbs

4) Connect module leads to microinverter DC connectors.



### Install Note:

Refer to the Enphase Frame Mount installation guide for additional instructions.

## INSTALLATION INSTRUCTIONS - DECK MOUNTED MLPE & RSD

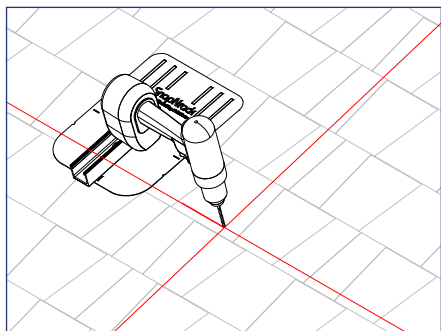

1) Drill pilot hole into decking with 3/16" drill bit, and apply roofing manufacturer's approved sealant to lag screw, in a circle around pilot hole, and fill pilot hole with sealant

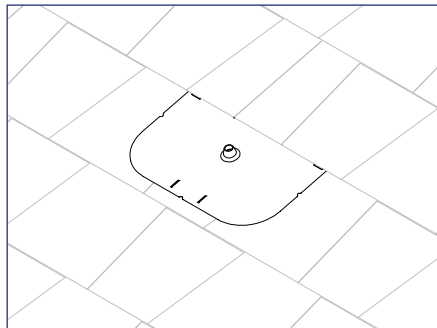

2) Install flashing underneath shingle course directly above pilot hole aligning hole in flashing with pilot hole.

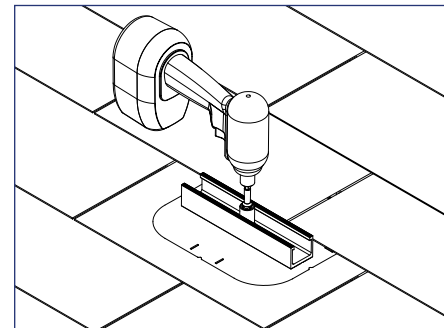

3) Place Flash Track over hole in flashing parallel with composition course, drive 2½" Umbrella Lag through hole in Flash Track, flashing, and into pilot hole

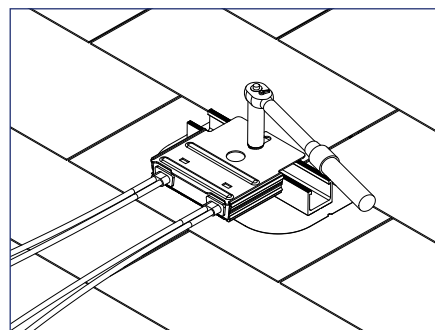
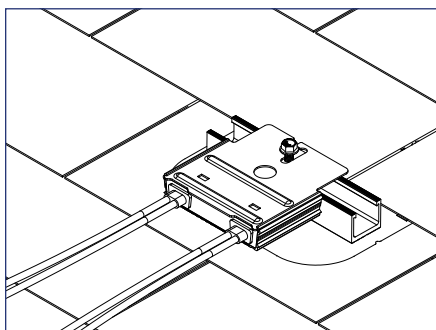
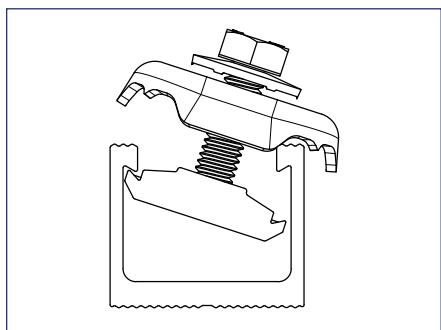

4) Insert channel nut of MLPE Attachment Kit into Flash Track, insert back plate of device over the large fender washer, and tighten bolt to 130 in-lb (10.8 ft-lb)

### Install Note:

The TopSpeed Universal SpeedSeal™ Track, SpeedSeal™ DeckTrack, AlphaTrack, or DeltaTrack can also be used as a means of attaching RSDs, junction boxes, and other hardware to the roof.

## Required Tools

- Socket Wrench
- Torque Wrench
- 1/2" Socket

## Materials Included

- ① SnapRack TopSpeed Universal Link
- ② TopSpeed Universal Mount

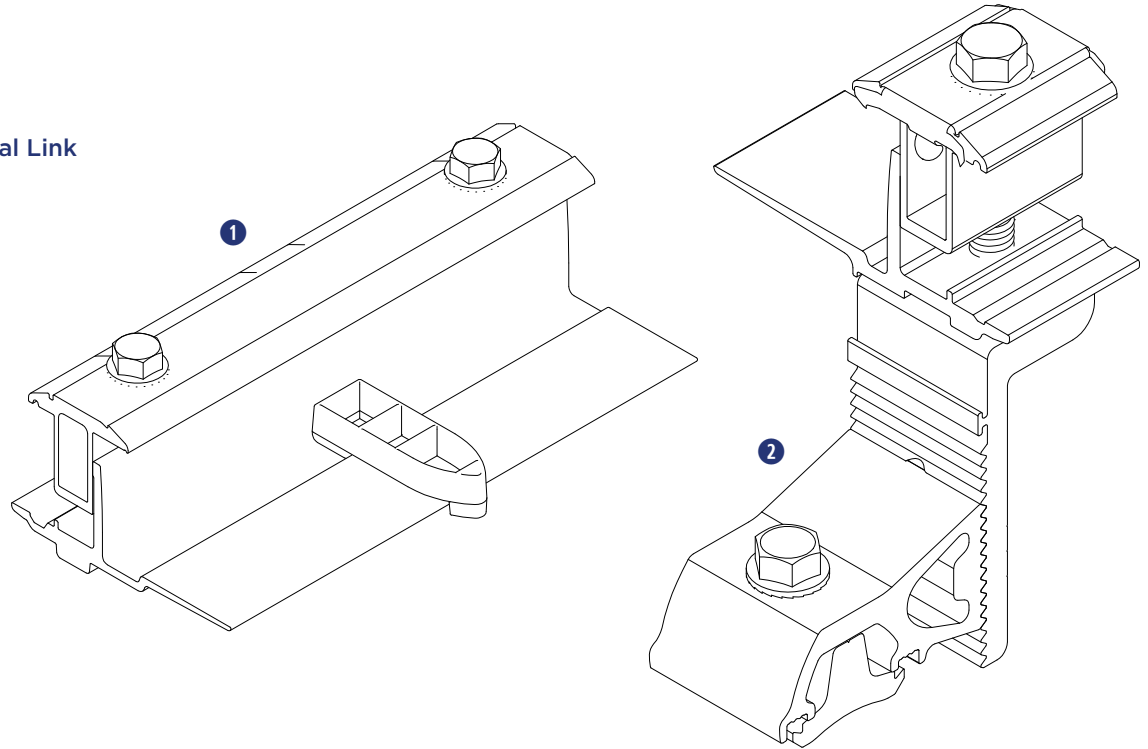

## Other Materials Required

- ② SnapRack Smart Clip (2-5 per module)
- ③ SnapRack Smart Clip XL (10-20 per array)  
*See Wire Management section for details*

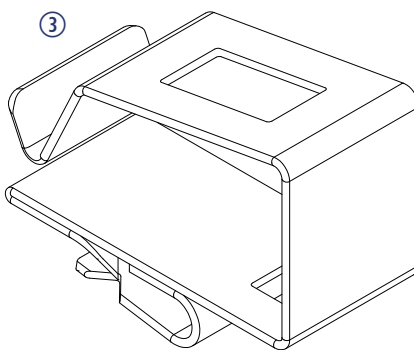
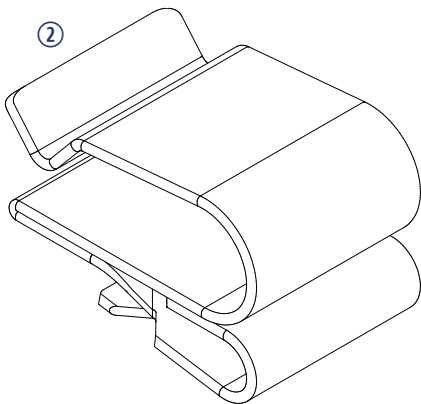

## INSTALLATION INSTRUCTIONS - BOTTOM ROW

### Install Note:

It is recommended that module leads and connectors are prepared for installation using SnapNrack Smart Clips before being brought to the rooftop.

- With no MLPE, secure module leads to module frame to allow access to connectors while modules are installed
- Secure MLPE device to module frame with SnapNrack MLPE Frame Attachment Kit and connect module leads to MLPE, and manage leads by positioning connectors to allow access during installation

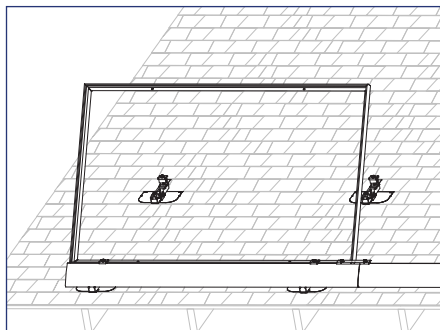

1) Rest downslope edge of module on the Mounts and/or Links position module so side edge is flush with marked edge of array layout

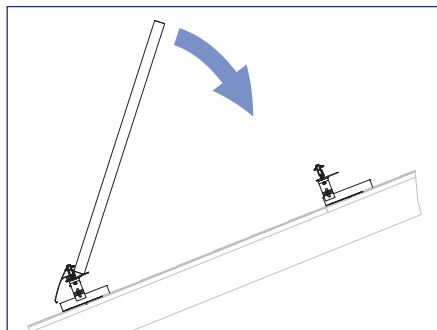

2) Lower upslope edge of module while simultaneously applying slight pressure to seat module into Mounts and/or Links

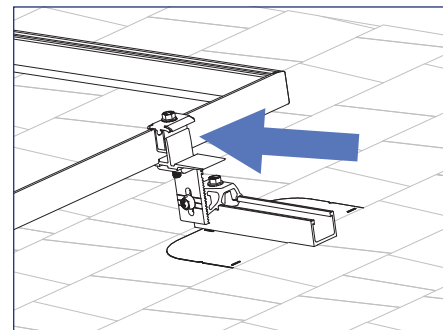

3) When module is level with roof slide Mount down the Flash Track, SpeedSeal™ Track, or SpeedSeal™ DeckTrack, and engage Mount clamp on upslope edge of module

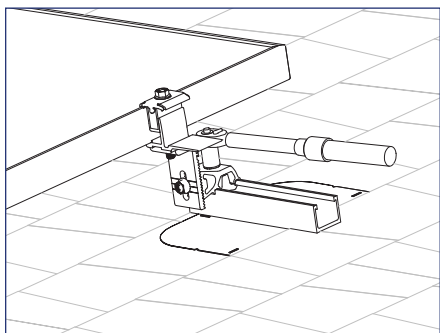

4) With the Mount fully engaged on the module frame first tighten channel nut bolt, then tighten Mount clamp bolt

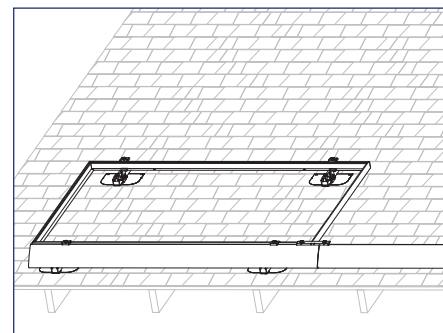
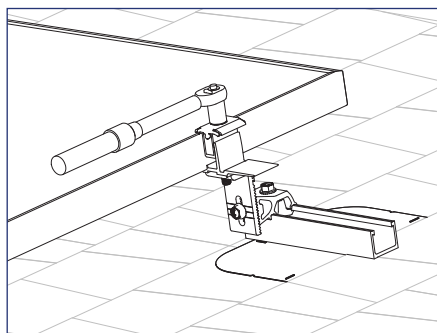

### Install Note:

Channel nuts must be fully engaged in track and must not extend beyond either end of the track.

## INSTALLATION INSTRUCTIONS - BOTTOM ROW

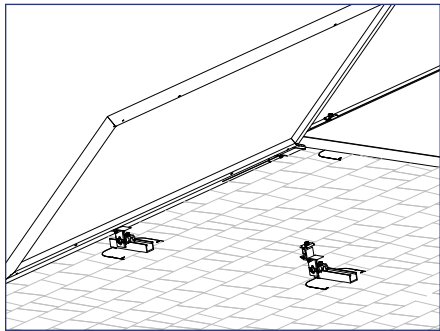

5) Install next module in row by placing downslope edge of module onto Links and Mounts then lower upslope edge of module until level with roof

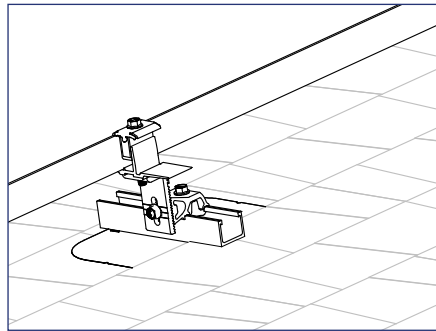

6) Slide Mount down the Flash Track, SpeedSeal™ Track or SpeedSeal™ DeckTrack, and position the Mount to support the Module

### Install Note:

Push modules together so they are tight against the Link module spacer

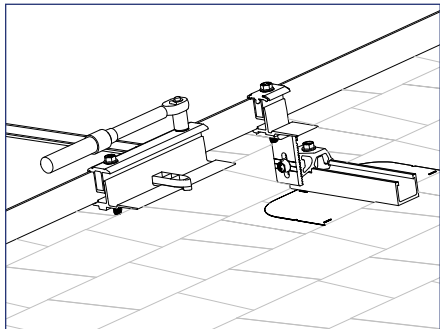

7) Attach Link to upslope side of modules tighten clamp bolts to engage both modules.

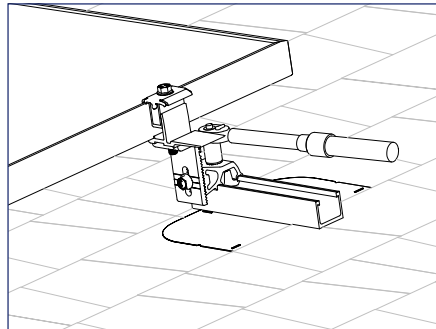

8) Engage Mounts on the module frame and tighten channel nut bolt, then tighten Mount clamp bolt.

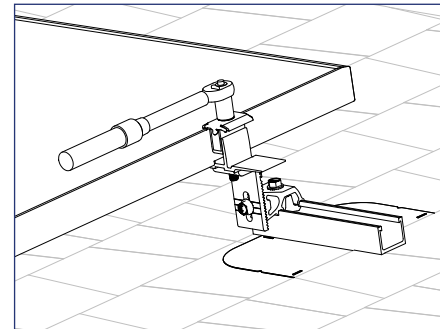

9) Repeat steps 5-7 for additional rows of modules in array

## GROUND PATH DETAILS

All TopSpeed Universal components in the fault current ground path have been Certified to be used multiple times for grounding/bonding. The UL 2703 Listing specifies the maximum number of uses of 5 for the Mount, Link, or OmniLug. Review the requirements of the National Electrical Code (NEC) Article 250 to select the appropriate Equipment Grounding Conductor size based on the short-circuit current of the PV system

When using OmniLug the following components are part of the fault current ground path:

- AlphaTrack
- DeltaTrack
- SnapNrack, SpeedSeal™ Track
- SnapNrack, Flash Track
- SnapNrack, Mount Assembly
- SnapNrack, Ridge Mount Assembly
- SnapNrack, Link
- SnapNrack, SkirtRail

## GROUND PATH DETAILS

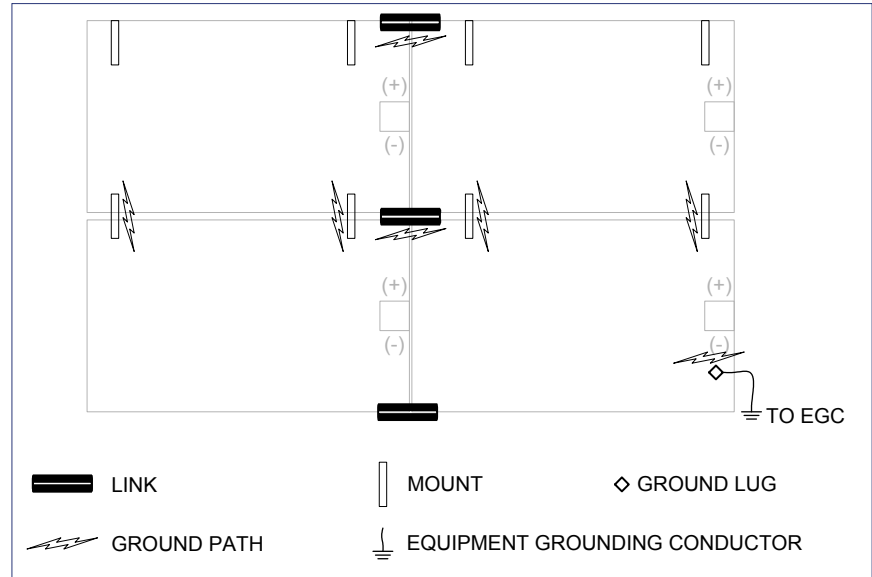

## GROUNDING METHOD DETAILS

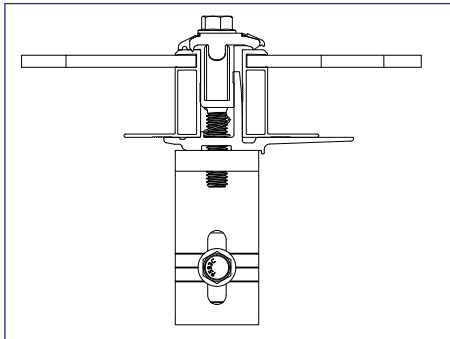

1) Row to row module bonding provided by bonding clip in Mount assembly

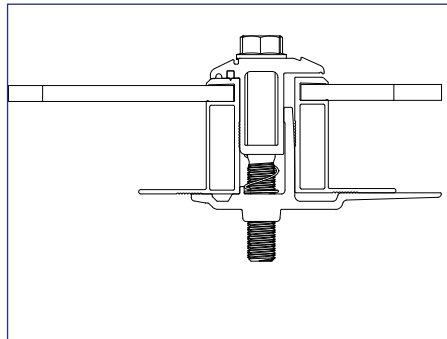

2) Column to column bonding provided by bonding clamp in Link assembly.  
Module heights evaluated for bonding with Link Bonding Clamps: 40mm, 38mm, 35mm, 32mm, 30mm

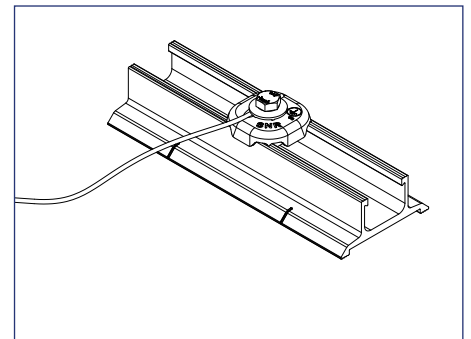

3) Each continuous array is connected to Equipment Grounding Conductor through OmniLug installed on one Flash Track, SpeedSeal™ Track, or SpeedSeal™ DeckTrack per array

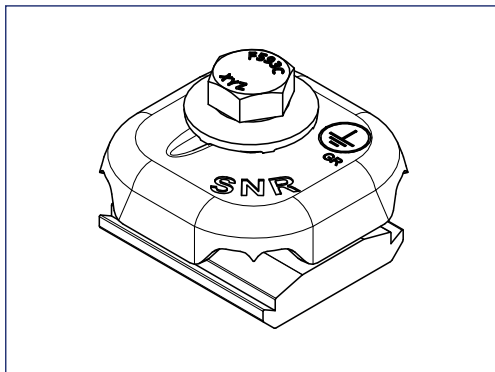

## GROUNDING MARKING DETAILS

The OmniLug is marked with the ground symbol.



## INSTRUCTION FOR MAINTAINING THE GROUNDING BONDING WHEN REMOVING A MODULE FOR SERVICING

**CAUTION:** Module removal may disrupt the bonding path and could introduce the risk of electric shock. Additional steps may be required to maintain the bonding path. Modules should only be removed by qualified persons in compliance with the instructions in this manual.

Module removal is not presented as a frequently expected occurrence and will not be required as part of routine maintenance.

Scenarios that could result in a disruption of the bonding path are described, for example irregularly shaped arrays, arrays consisting of individual rows, and any other scenario where module removal could disrupt the bonding path.

In most cases, the removal of a module for servicing will not disturb or break grounding continuity. If a module is to be removed that will break continuity, these are the steps that must be taken to maintain a continuously bonded SnapNrack TopSpeed Universal System.

### Required Tools

- Socket Wrench
- Torque Wrench
- 1/2" Socket
- 7/16" Socket

### Required Materials

- 1 #10 Or Larger Bare Copper Conductor
- 2 SnapNrack SKU 242-10034
- 3 IlSCO Part No. SGB-4
- 4 DnoRaxx Dynobond™

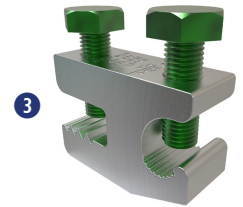

# Maintaining the Grounding Bonding When Removing a Module

## JUMPER ASSEMBLY INSTRUCTION & INSTALLATION

**CAUTION:** Do Not Remove the Module until the Jumper is installed

1) Identify the existing ground path at the location of module removal and choose an appropriate length of #10 bare copper to bridge the soon to be broken ground path.

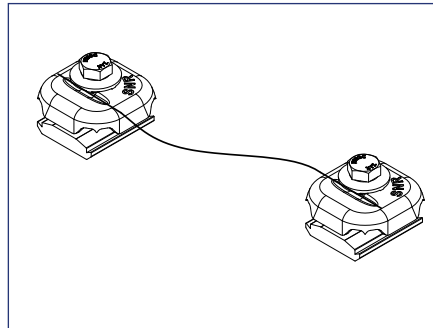

*Example of assembled bonding jumper using (2) SnapNrack OmniLugs*

2) Attach one ground lug to each end of #10 bare copper wire. See recommended options below:

1. (2) SnapNrack SKU: 242-10034
2. (2) IlSCO part no. SGB-4
3. (1) SnapNrack part no. 242-10034 & (1) IlSCO part no. SGB-4
4. (1) DroRaxx DynoBond™

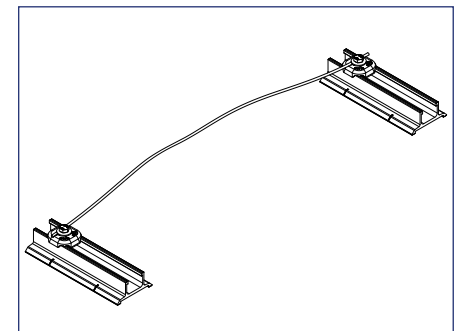
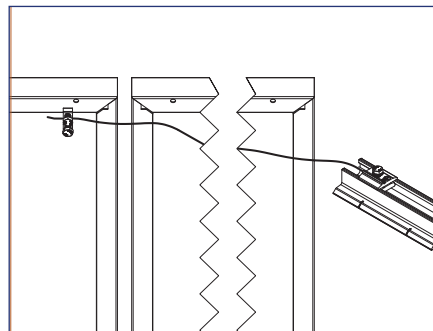
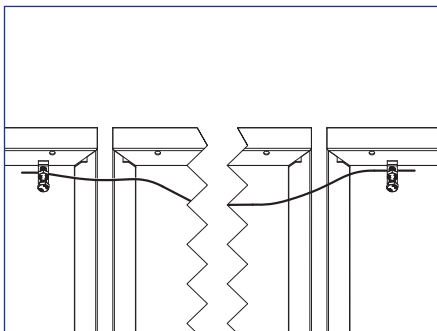

3) Before the module is removed, attach the assembled bonding jumper. Depending on where the module will be removed and choice of ground lug, jumper attachment locations will vary.

- IlSCO SGB-4 lugs can be attached to TopSpeed Universal Tracks, Mounts, or module frames
- The SnapNrack Ground Lug can only be attached to SnapNrack TopSpeed Universal tracks including; Flash Tracks, SpeedSeal™ Tracks, SpeedSeal™ DeckTracks.
- DynoRaxx DynoBond™ is approved and appropriate when a short bonding jumper is needed from module to module.

4) Service the array. With the bonding jumper installed, it is now safe to remove the module for service or maintenance.

5) After Servicing the array reinstall the module and original ground path. Only then Remove the bonding jumper.

**Caution:** Do not remove the bonding jumper until original ground path is established.

# List of Approved Modules

## APPROVED MODULE INFORMATION

SnapNrack TopSpeed Universal has been tested with the following UL Listed module series: The SnapNrack TopSpeed Universal system employs top-down clamps and links which have been evaluated for frame-to-system bonding, at specific mounting torques and with the specific module series listed below. All wattage values are covered.

Module manufacturer approval letters can be found at [www.snaprack.com](http://www.snaprack.com).

Manufacturer	Model	
Aptos Solar	DNA-120-MF23-XXX	DNA-120-BF26-XXXW
	DNA-120-BF23-XXX	DNA-144-BF26-XXXW
	DNA-144-MF23-XXX	DNA-108-BF10-xxxW
	DNA-144-BF23-XXX	DNA-120-BF10-xxxW
	DNA-120-MF26-XXXW	DNA-108-MF10-xxxW
	DNA-144-MF26-XXXW	
Boviet Solar	BVM7612M-XXX-H-HC-BF-DG	
Canadian Solar	CS6K-XXX-M	CS1H-XXX-MS-AB
	CS6K-XXX-M-SD	CS3W-XXX-P
	CS6K-XXX-P	CS3N-XXX-MS
	CS6K-XXX-P-SD	CS1Y-XXX-MS
	CS6K-XXX-MS	CS3W-MB-AG
	CS3K-XXX-P	CS3Y-MB-AG
	CS3K-XXX-MS	CS6W-XXXMB-AG
	CS3U-XXX-MS	CS6R-XXXMS-HL
	CS3U-XXX-P	CS3W-XXX-MS
	CS1K-XXX-MS	CS6.1-54TM-XXX-H
	CS1H-XXX-MS	
CertainTeed	CTXXXHC11-06	
Chint Solar	CHSM6612M-XXX	CHSM72M-HC-XXX* (Astro 4)
	CHSM6612M(BL)-XXX	CHSM72M-HC-XXX* (Astro 5)
	CHSM6612M/HV-XXX	
Dehui Solar	DH-M760B-XXXW	DH-M760F-XXXW
	DH-M760W-XXXW	DH-M772F-XXXW
	DH-M772W-XXXW	
Freedom Forever	FF-MP-BBB-xxx	
Hanwha Q Cells	Q.PEAK DUO-G5-XXX	Q.PEAK DUO G10-XXX
	Q.PEAK DUO-BLK-G5-XXX	Q.PEAK DUO BLK G10-XXX
	Q.PLUS DUO-G5-XXX	Q.PEAK DUO G10+-XXX
	Q.PEAK DUO-G7-XXX	Q.PEAK DUO BLK G10+-XXX
	Q.PEAK DUO-BLK-G7-XXX	Q.PEAK DUO XL-G10.3-XXX
	Q.PEAK DUO-G7.2-XXX	Q.PEAK DUO XL-G10.c-XXX
	Q.PEAK DUO-G6+-XXX	Q.PEAK DUO XL-G10.d-XXX
	Q.PEAK DUO-BLK-G6+-XXX	Q.PEAK DUO L-G8.3/BFG-XXX
	Q.PEAK DUO-G6-XXX	Q.PEAK DUO L-G8.3/BGT-XXX
	Q.PEAK DUO-BLK-G6-XXX	Q.PEAK DUO ML-G10-XXX
	Q.PEAK DUO-G8+-XXX	Q.PEAK DUO BLK ML-G10+-XXX

# List of Approved Modules

Manufacturer	Model	
Hanwha Q Cells	Q.PEAK DUO-BLK-G8+-XXX	Q.PEAK DUO BLK ML-G10-XXX
	Q.PEAK DUO-G8-XXX	Q.PEAK DUO ML-G10.a+-XXX
	Q.PEAK DUO-BLK-G8-XXX	Q.PEAK DUO BLK ML-G10.a+-XXX
	Q.PEAK DUO BLK-G6+/AC-XXX	Q.PEAK DUO ML-G10.a-XXX
	Q.PEAK DUO-ML-G9-XXX	Q.PEAK DUO BLK ML-G10.a-XXX
	Q.PEAK DUO-BLK-ML-G9-XXX	Q.PEAK DUO BLK G10+/AC XXX
	Q.PEAK DUO-BLK-G9-XXX	Q.PEAK DUO BLK G10+/HL XXX
	Q.PEAK DUO-BLK-ML-G9+-XXX	Q.PEAK DUO BLK ML-G10+/t-XXX
	Q.PEAK DUO-ML-G9+-XXX	Q.PEAK DUO XL-G11.3 XXX
	Q.PEAK DUO-BLK-ML-G9+-XXX	Q.PEAK DUO XL-G11.3 BFG XXX
	Q.PEAK DUO XL-G9.2-XXX	Q.TRON-G1+ XXX
	Q.PEAK DUO XL-G9.3-XXX	Q.TRON BLK-G1+ XXX
	Q.PEAK DUO XL-G9.3/BFG-XXX	Q.TRON M-G2+ XXX
	Q.PEAK DUO XL-G10.2-XXX	Q.TRON BLK M-G2+ XXX
	Q.PEAK DUO XL-G10.3/BFG-XXX	Q.TRON XL-G2.3/BFG XXX
	Q.PEAK DUO ML-G10+-XXX	Q.TRON BLK M-G2+/AC
HT-SAAE	HT60-166M-XXX	HT60-182M-XXX
Heliene	60M-XXX	72M-XXX
	60P-XXX	72P-XXX
"Hyundai (All may be followed by "BK")"	HiA-SXXXMS	HiS-SXXXI
	HiS-SXXXXY	HiS-SXXXH(BK)
	HiN-SxxxXG(BK)	
Hyperion/Runergy	HY-DH108P8-XXX(Y)	HY-DH144N8-XXX
	HY-DH144P8-XXX	HY-DH108N8-XXX
JA Solar	JAM60S09-XXX/PR	JAM72S10-XXX/PR
	JAM60S10-XXX/MR	JAM72S12-XXX/PR
	JAM60S10-XXX/PR	JAM60S17-XXX/MR
	JAM60S12-XXX/PR	JAM54S30-XXX/MR
	JAM72S09-XXX/PR	JAM54S31-XXX/MR
	JAM72S10-XXX/MR	JAM72D30-XXX/MB
	JAM72D10-XXX/MB	
Jinko Solar	JKMXXXM-60	JKMXXXP-72-V
	JKMXXXM-60L	JKMXXXPP-72
	JKMXXXM-60HL	JKMXXXPP-72-V
	JKMXXXM-60HBL	JKMXXXP-72
	JKMXXXP-60	JKMXXXM-72HL-V
	JKMXXXP-60-J4	JKMXXXM-72HL-TV
	JKMXXXP-60-V	JKMXXXM-72HBL
	JKMXXXP-60B-J4	JKMXXXM-6TL3-B
	JKMXXXPP-60	JKMXXXM-6TopSpeed3-B
	JKMXXXPP-60-V	JKMXXXM-7TopSpeed3-V
	JKMXXXM-72	JKMXXXM-7TopSpeed3-TV
	JKMXXXM-72L-V	JKMXXXM-72HL4-V
	JKMXXXP-72	JKMXXXM-72HL4-TV

# List of Approved Modules

Manufacturer	Model	
KB Solar	MODULE-KBS-375-MONO	MODULE-KBS-450-MONO
	MODULE-KBS-375-MONO-BF	MODULE-KBS-450-MONO-BF
LG	LGXXN1C-A5	LGXXXA1C-V5
	LGXXN1K-A5	LGXXXM1C-L5
	LGXXXQ1C-A5	LGXXXM1K-L5
	LGXXXQ1K-A5	LGXXXN1C-N5
	LGXXS1C-A5	LGXXXN1K-L5
	LGXXN2C-B3	LGXXXN1K-A6
	LGXXN2W-B3	LGXXXN1C-A6
	LGXXN1C-G4	LGXXXN1W-A6
	LGXXN1K-G4	LGXXXQ1C-A6
	LGXXS1C-G4	LGXXXQ1K-A6
	LGXXN2C-G4	LGXXXM1K-A6
	LGXXN2K-G4	LGXXXM1C-A6
	LGXXN2W-G4	LGXXXA1C-A6
	LGXXS2C-G4	LGXXXQAC-A6
	LGXXS2W-G4	LGXXXQAK-A6
	LGXXN1C-V5	LGXXXN1K-B6
	LGXXN1W-V5	LGXXXN2W-E6
	LGXXN2T-V5	LGXXXN2T-E6
	LGXXN2T-J5	LGXXXN1K-E6
	LGXXN1T-V5	LGXXXN3K-V6
Longi	LR6-60-XXXM	LR4-60HIB-XXXM
	LR6-60BK-XXXM	LR4-60HPH-XXXM
	LR6-60HV-XXXM	LR4-60HIH-XXXM
	LR6-60PB-XXXM	LR6-60HIH-XXXM
	LR6-60PE-XXXM	LR6-60HIB-XXXM
	LR6-60PH-XXXM	LR4-72HPH-XXXM
	LR6-60HPB-XXXM	LR5-72HPB-XXXM
	LR6-60HPH-XXXM	LR5-54HABB-XXXM
	LR4-60HPB-XXXM	
Meyer Burger	Meyer Burger Black*	Meyer Burger White*
mSolar	TXI6-XXX120BB	TXI10-XXX108BB
Mission Solar	MSEXXS05T	MSEXXS8K
	MSEXXS05K	MSEXXS8T
	MSEXXSQ5T	MSEXXS9S
	MSEXXSQ5K	MSE60AXXX
	MSEXXM4J	MSEXXS5K
	MSEXXM6J	MSEXXS5T
	MSEXXS06W	MSEXXS6S
	MSEXXS04J	MSEXXS6W
	MSEXXS06J	MSEXXS5R
	MSEXXSQ6S	MSE410HT0B
	MSEXXSQ4S	

# List of Approved Modules

Manufacturer	Model	
Next Energy Alliance	USNEA-XXXM3-60	USNEA-XXXM3-72
	USNEA-XXXM3B-60	USNEA-XXXM3B-72
Panasonic	VBHNXXXKA03	VBHXXXRA03K
	VBHNXXXKA04	EVPVXXX(K)
	VBHNXXXSA17	EVPVXXXH
	VBHNXXXSA18	EVPVXXXPK
	VBHN325SA17E	EVPVXXXHK2
	VBHXXXRA18N	
Philadelphia Solar	PS-M144(HCBF)-XXXW	PS-M108(HC)-XXXW
	PS-M108(HCBF)-XXXW	
Phono Solar	PSXXXM-20/U	PSxxxM8GF-18/VH
	PSXXXMH-20/U	PSxxxM8GFH-18/VH
	PSxxxM8GF-24/TH	PSxxxM6-24/TH
	PSxxxM8GFH-24/TH	
REC (All may be followed by "BLK" or "BLACK")	RECXXTP2	RECXXTP2SM 72 BLK2
	RECXXTP2-BLK	RECXXXAA
	RECXXNP	RECXXTP3M
	RECXXTP2M	RECXXTP4
	RECXXTP2M 72	RECXXXAA Pure
	RECXXTP2M 72 BLK	RECXXXAA Pure-R
	RECXXTP2M 72 BLK2	RECXXNP2
	RECXXTP2SM 72	RECXXNP3
RECXXTP2SM 72 BLK		
SEG Solar	SEG-400-BMB-HV	SEG-xxx-BMD-HV
	SEG-400-BMB-TB	SEG-xxx-BMD-TB
Silfab	SLAXXX-M	SILXXXNT
	SLAXXX-P	SILXXXHL
	SSAXXX-M	SILXXXBK
	SSAXXX-P	SILXXXNX
	SILXXXBL	SILXXXNU
	SILXXXML	SILXXXHC
	SILXXXNL	SILXXXHN
	SLGXXX-M	SILXXXBG
	SLGXXX-P	SIL-xxxHC+
	SSGXXX-M	SIL-xxxHM
	SSGXXX-P	
Solar4America	S4AXXX60H5BB	S4AXXX72H5BW
	S4AXXX60H5BW	S4AXXX72M5BB
	S4AXXX60M5BB	S4AXXX72M5BW
	S4AXXX60M5BW	S4AXXX-108MH10
	S4AXXX72H5BB	S4AXXX-144MH10
Solaria	Solaria PowerXT-XXXR-PX	Solaria PowerXT-XXXR-PM
	Solaria PowerXT-XXXR-BX	Solaria PowerXT-XXXR-PM-AC
	Solaria PowerXT-XXXR-AC	

# List of Approved Modules

Manufacturer	Model	
Sunpower	SPR-AXXX-G-AC	SPR-MXXX
	SPR-AXXX	SPR-MXXX-BLK-H-AC
	SPR-AXXX-BLK-G-AC	SPR-MXXX-BLK
	SPR-AXXX-BLK	SPR-MAX3-XXX-BLK-R
	SPR-MXXX-H-AC	
SunSpark	SST-XXXM3-60	SST-XXXM3-72
	SST-XXXM3B-60	SST-XXXM3B-72
Talesun	TP660M-XXX	TP672M-XXX
	TP660P-XXX	TP672P-XXX
Thornova	TS-BB54(XXX)	TS-BG60(XXX)
	TS-BB60(XXX)	TS-BG72(XXX)
	TS-BG54(XXX)	
Trina	TSM-XXXDD05(II)	TSMXXXDD05H.05(II)
	TSM-XXXDD05A.05(II)	TSM-XXXDD06M.05(II)
	TSM-XXXDD05A.08(II)	TSM-XXXDE15H(II)
	TSM-XXXDD05A.082(II)	TSM-XXXDE15M(II)
	TSM-XXXPA05	TSMXXXDE06X.05(II)
	TSM-XXXPA05.05	TSMXXXDE09.05
	TSM-XXXPA05.08	TSM-XXXDE15V(II)
	TSM-XXXPD05	TSM-XXXDEG15VC.20(II)
	TSM-XXXPD05.002	TSM-XXXDEG18MC.20(II)
	TSM-XXXPD05.05	TSM-XXXDEG19C.20
	TSM-XXXPD05.05S	TSM-XXXDEG21C.20
	TSM-XXXPD05.08	TSM-XXXDE09C.05
	TSM-XXXPD05.082	TSM-XXXDE09C.07
	TSM-XXXPD05.08D	TSM-xxxNE09RC.05
	TSM-XXXPD05.08S	
Ureco	FBMxxxMFG-BB	FAMxxxE7G-BB
Vikram Solar	SOMERA VSMHBB.60.XXX.05	PREXOS VSM DHT.60.XXX.05
	SOMERA VSMH.72.XXX.05	PREXOS VSM DHT.72.XXX.05
VSUN	VSUNXXX-144BMH-DG	VSUNXXX-108BMH
	VSUNXXX-120BMH	VSUNXXX-132BMH
ZNShine	ZXM6-60-XXX/M	ZXM6-NH144-XXXM
	ZXM6-NH120-XXXM	ZXM7-SH108-XXXM
	ZXM7-SHLDD144-XXXM	

# List of Approved MLPE Devices

**SnapNrack TopSpeed Universal has been tested with the following Module Level Power Electronic (MLPE) devices:**

SnapNrack TopSpeed Universal mounting systems has been tested with the following UL/NRTL Listed Module Level Power Electronic (MLPE) Devices. The back plates of the MLPEs have been evaluated for bonding to TopSpeed Universal through the SnapNrack MLPE Frame Attachment Kit, model 242-02151.

MLPE Manufacturer	Model	
AP Smart	RSD-S-PLC	
Celastica International	DG-006-F001201x	DG-006-F001401x
Delta Electronics	GPIO0010105	
Enphase	C250	IQ7PLUS-72-2-US
	M215	IQ7PLUS-72-B-US
	M250	IQ8-60
	IQ6-60-2-US	IQ8PLUS-72
	IQ6PLUS-72-2-US	IQ8A-72
	IQ7-60-2-US	IQ8H-208-72
	IQ7-60-B-US	IQ8H-240-72
Generec	S2502	
Ginlong Technologies	Solis-RSD-1G	
	Solis-MLRSD-R1-1G	Solis-MLRSD-R2-1G
SolarEdge	P300-5NC4ARS	P320-5NC4ARS
	P370-5NC4AFS	P400-5NC4AFS
	P320	P340
	P370	P400
	P401	P405
	P485	P505
	P730	P800p
	P850	P860
	P950	P1100
	P1101	S440
	S500	
SMA	RSB-2S-US-10	
Tigo	TS4-R-F	TS4-R-M
	TS4-R-O	TS4-R-S
	TS4-R-M-DUO	TS4-R-O-DUO
	TS4-R-S-DUO	TS4-A-F
	TS4-A-2F	TS4-A-O
	TS4-A-S	