

DESCRIPTION:
**ULTRA RAIL WIDE BASE SEAM CLAMP WITH
 SIMPLE TILT FRONT LEG 10 DEG PORTRAIT**

DOC NUMBER:
 SNR-DC-01355

SnapNrack®

PART NUMBER(S):

242-92125

DRAWN BY:
 H.WULFEKOETTER

REV: **C** DATE:
 1/23/2023

SUNRUN INSTALLATION SERVICES INC.
 225 BUSH STREET, SUITE 1400 • SAN FRANCISCO, CA 94104 USA
 PHONE (877) 732-2860 • CONTACT@SNAPNRACK.COM
THE INFORMATION IN THIS DRAWING IS CONFIDENTIAL AND PROPRIETARY. ANY REPRODUCTION, DISCLOSURE, OR USE THEREOF IS PROHIBITED WITHOUT THE WRITTEN CONSENT OF SUNRUN SOUTH LLC.

UNITS: IN, LB, DEG [MM, KG, DEG]

SHEET: 1:3

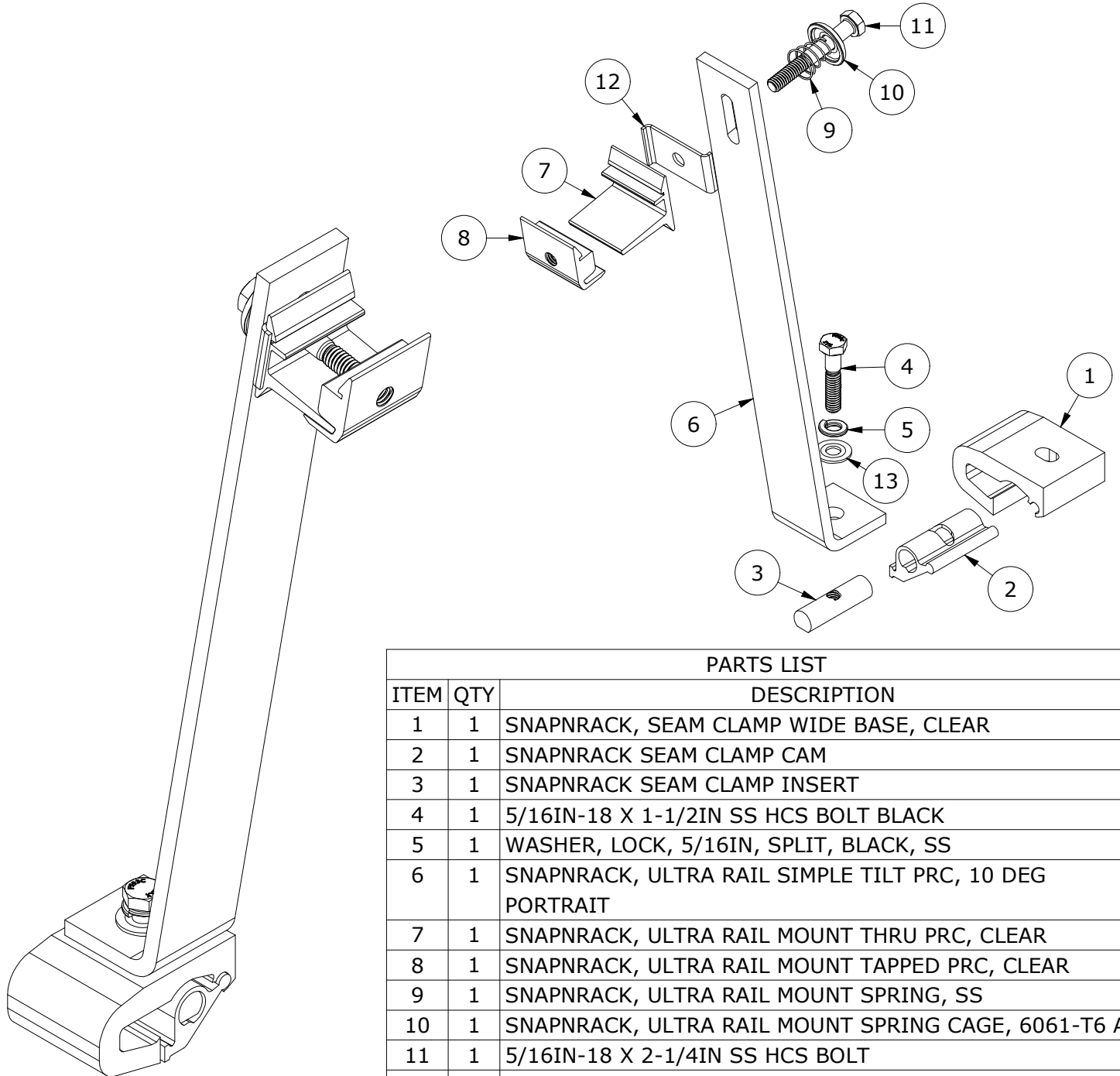

PARTS LIST

ITEM	QTY	DESCRIPTION
1	1	SNAPNRACK, SEAM CLAMP WIDE BASE, CLEAR
2	1	SNAPNRACK SEAM CLAMP CAM
3	1	SNAPNRACK SEAM CLAMP INSERT
4	1	5/16IN-18 X 1-1/2IN SS HCS BOLT BLACK
5	1	WASHER, LOCK, 5/16IN, SPLIT, BLACK, SS
6	1	SNAPNRACK, ULTRA RAIL SIMPLE TILT PRC, 10 DEG PORTRAIT
7	1	SNAPNRACK, ULTRA RAIL MOUNT THRU PRC, CLEAR
8	1	SNAPNRACK, ULTRA RAIL MOUNT TAPPED PRC, CLEAR
9	1	SNAPNRACK, ULTRA RAIL MOUNT SPRING, SS
10	1	SNAPNRACK, ULTRA RAIL MOUNT SPRING CAGE, 6061-T6 AL
11	1	5/16IN-18 X 2-1/4IN SS HCS BOLT
12	1	SNAPNRACK, SEAM CLAMP ROTATION LOCK
13	1	5-16IN X 3-4IN SS FLAT WASHER

MATERIALS:

6000 SERIES ALUMINUM, STAINLESS STEEL

DESIGN LOAD (LBS):

N/A

ULTIMATE LOAD (LBS):

N/A

TORQUE SPECIFICATION:

15-16 FT-LBS

CERTIFICATION:

UL 2703, FILE E359313

WEIGHT (LBS):

1.14

DESCRIPTION:
**ULTRA RAIL WIDE BASE SEAM CLAMP WITH
 SIMPLE TILT FRONT LEG 10 DEG PORTRAIT**

DOC NUMBER:
 SNR-DC-01355

SnapNrack®

PART NUMBER(S):

242-92125

DRAWN BY:
 H.WULFEKOETTER

REV: **C** DATE: 1/23/2023

SUNRUN INSTALLATION SERVICES INC.

225 BUSH STREET, SUITE 1400 • SAN FRANCISCO, CA 94104 USA
 PHONE (877) 732-2860 • CONTACT@SNAPNRACK.COM

THE INFORMATION IN THIS DRAWING IS CONFIDENTIAL AND PROPRIETARY. ANY REPRODUCTION, DISCLOSURE, OR USE THEREOF IS PROHIBITED WITHOUT THE WRITTEN CONSENT OF SUNRUN SOUTH LLC.

UNITS: IN, LB, DEG [MM, KG, DEG]

SHEET: 2:3

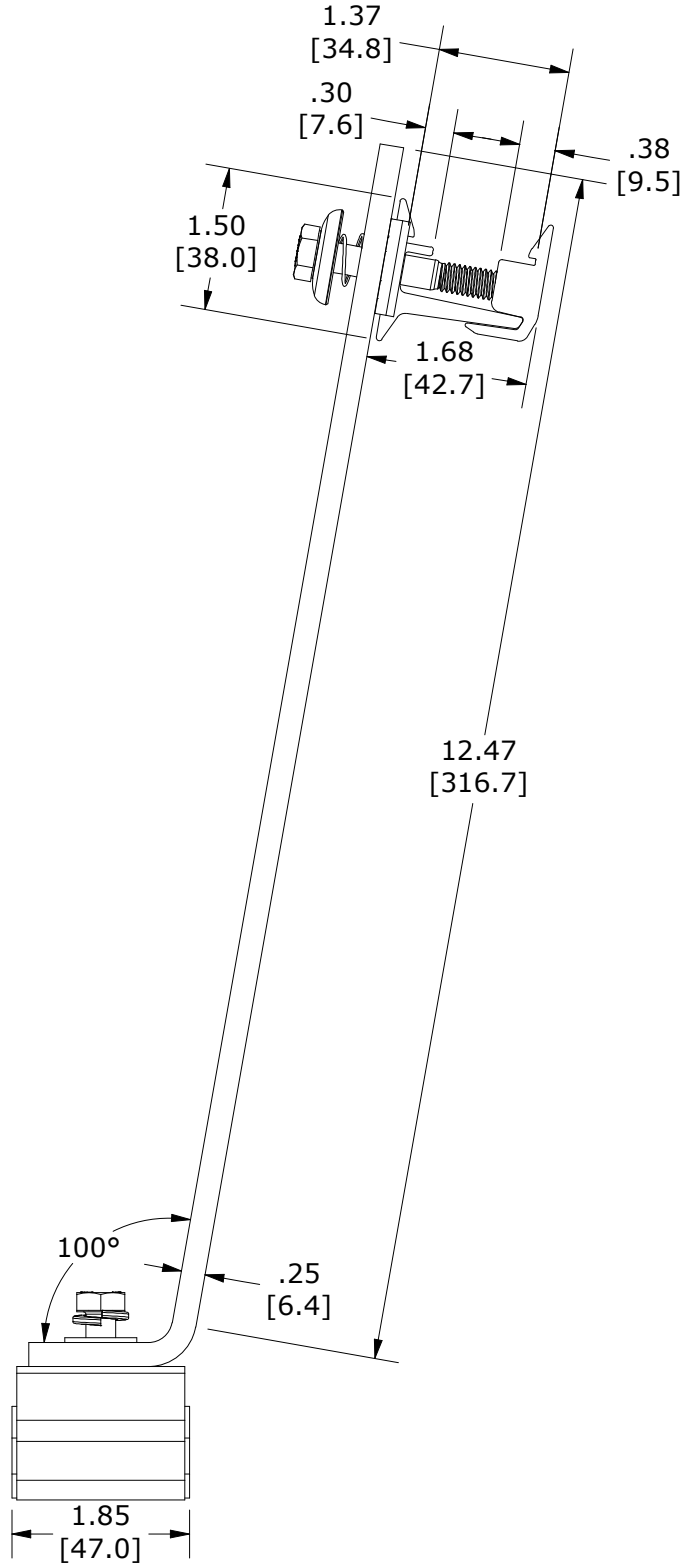
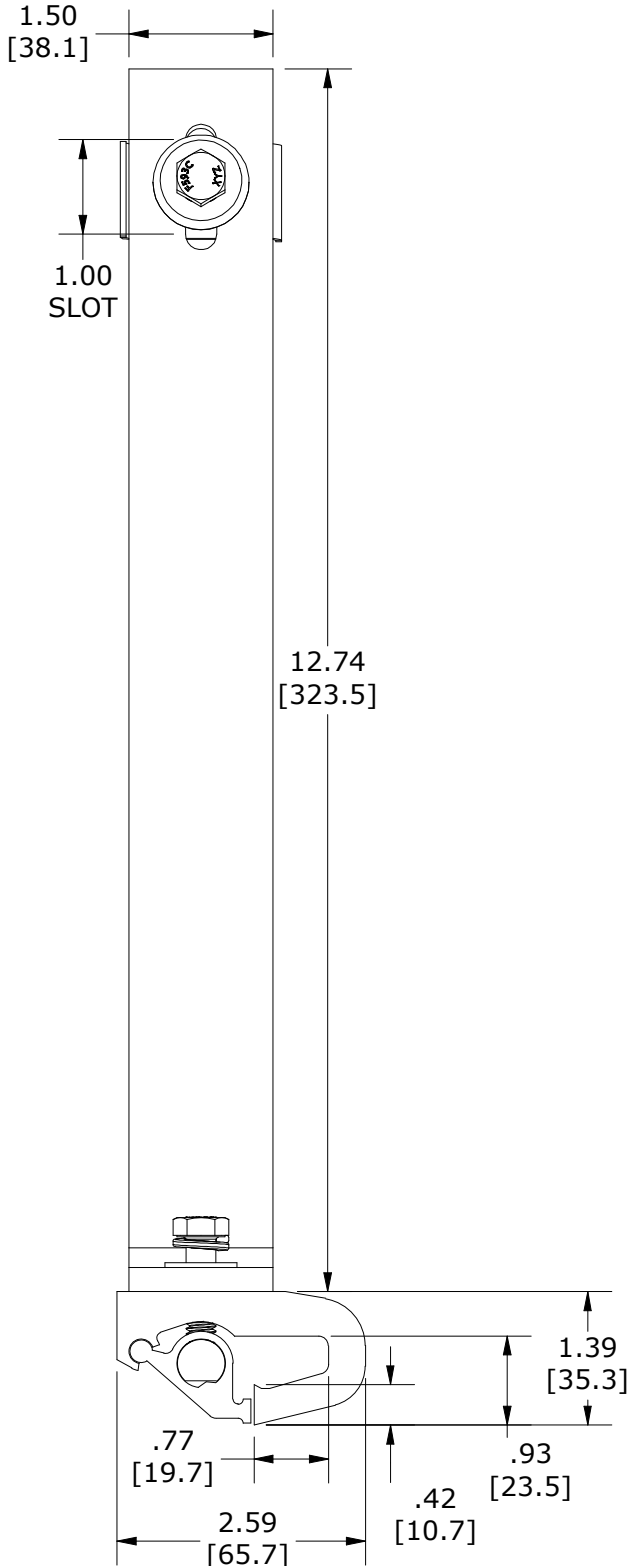

DESCRIPTION:
**ULTRA RAIL WIDE BASE SEAM CLAMP WITH
 SIMPLE TILT FRONT LEG 10 DEG PORTRAIT**

DOC NUMBER:
 SNR-DC-01355

SnapNrack®

PART NUMBER(S):

242-92125

DRAWN BY:
 H.WULFEKOETTER

REV: **C** DATE:
 1/23/2023

SUNRUN INSTALLATION SERVICES INC.
 225 BUSH STREET, SUITE 1400 • SAN FRANCISCO, CA 94104 USA
 PHONE (877) 732-2860 • CONTACT@SNAPNRACK.COM
THE INFORMATION IN THIS DRAWING IS CONFIDENTIAL AND PROPRIETARY. ANY REPRODUCTION, DISCLOSURE, OR USE THEREOF IS PROHIBITED WITHOUT THE WRITTEN CONSENT OF SUNRUN SOUTH LLC.

UNITS: IN, LB, DEG [MM, KG, DEG]

SHEET: 3:3

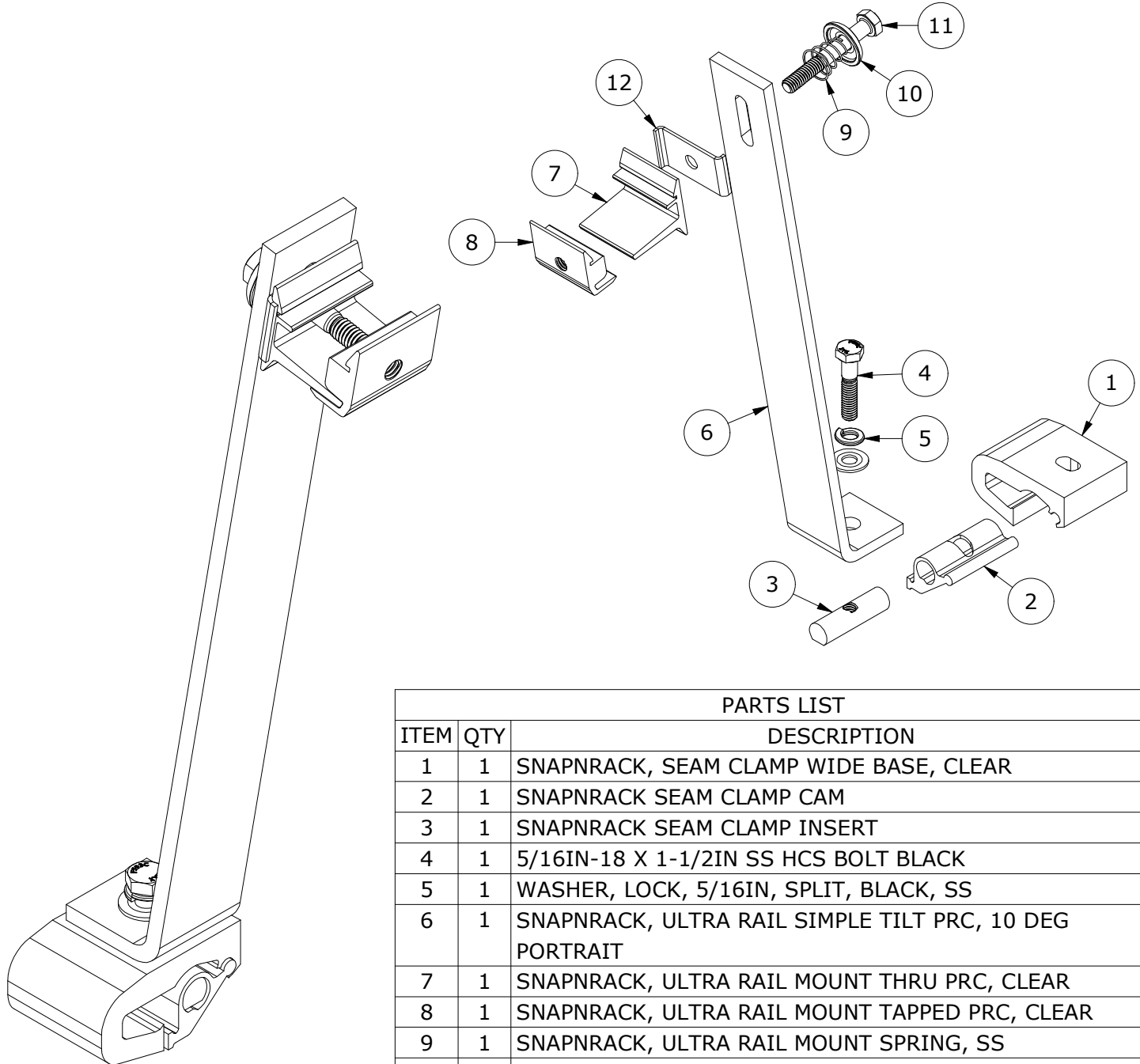

PARTS LIST

ITEM	QTY	DESCRIPTION
1	1	SNAPNRACK, SEAM CLAMP WIDE BASE, CLEAR
2	1	SNAPNRACK SEAM CLAMP CAM
3	1	SNAPNRACK SEAM CLAMP INSERT
4	1	5/16IN-18 X 1-1/2IN SS HCS BOLT BLACK
5	1	WASHER, LOCK, 5/16IN, SPLIT, BLACK, SS
6	1	SNAPNRACK, ULTRA RAIL SIMPLE TILT PRC, 10 DEG PORTRAIT
7	1	SNAPNRACK, ULTRA RAIL MOUNT THRU PRC, CLEAR
8	1	SNAPNRACK, ULTRA RAIL MOUNT TAPPED PRC, CLEAR
9	1	SNAPNRACK, ULTRA RAIL MOUNT SPRING, SS
10	1	SNAPNRACK, ULTRA RAIL MOUNT SPRING CAGE, 6061-T6 AL
11	1	5/16IN-18 X 2-1/4IN SS HCS BOLT

MATERIALS:

6000 SERIES ALUMINUM, STAINLESS STEEL, SNAPNRACK SEAM CLAMP ROTATION LOCK

DESIGN LOAD (LBS):

N/A

ULTIMATE LOAD (LBS):

N/A

TORQUE SPECIFICATION:

15-16 FT-LBS

CERTIFICATION:

UL 2703, FILE E359313

WEIGHT (LBS):

1.14