

SEE ENGINEERING TABLES FOR PIER DEPTHS AND SPAN LIMITATIONS.

UNLESS OTHERWISE SPECIFIED IN ENGINEERING DOCS, THE FOLLOWING VALUES APPLY.

MAX RAIL LENGTH (RL) IS 214"

MAX RAIL SPAN (RS):
 3-HIGH = 6'-0"
 4-HIGH = 8'-6"
 5-HIGH = 11'-0"

MAX RAIL OVERHANG (RO):
 3-HIGH = 29"
 4-HIGH = 35"
 5-HIGH = 41"

MAXIMUM MODULE WEIGHT IS 65 LBS

GROUND RAIL SPLICE MUST ALWAYS BE INSTALLED BETWEEN HORIZONTAL PIPES

MODULE CLAMPS CANNOT BE INSTALLED WHERE GROUND RAIL SPLICE IS LOCATED

REVISION:		
G	12/1/2013	NSSE UPDATE DR
H	4/4/2018	PZSE UPDATE DR
I	10/11/2021	5-HIGH CONFIG MKW

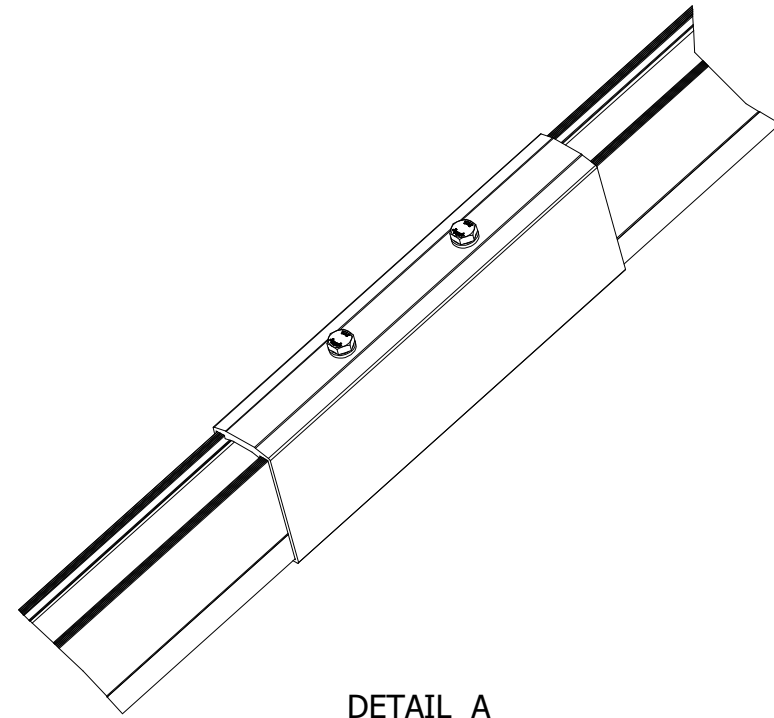

DETAIL A

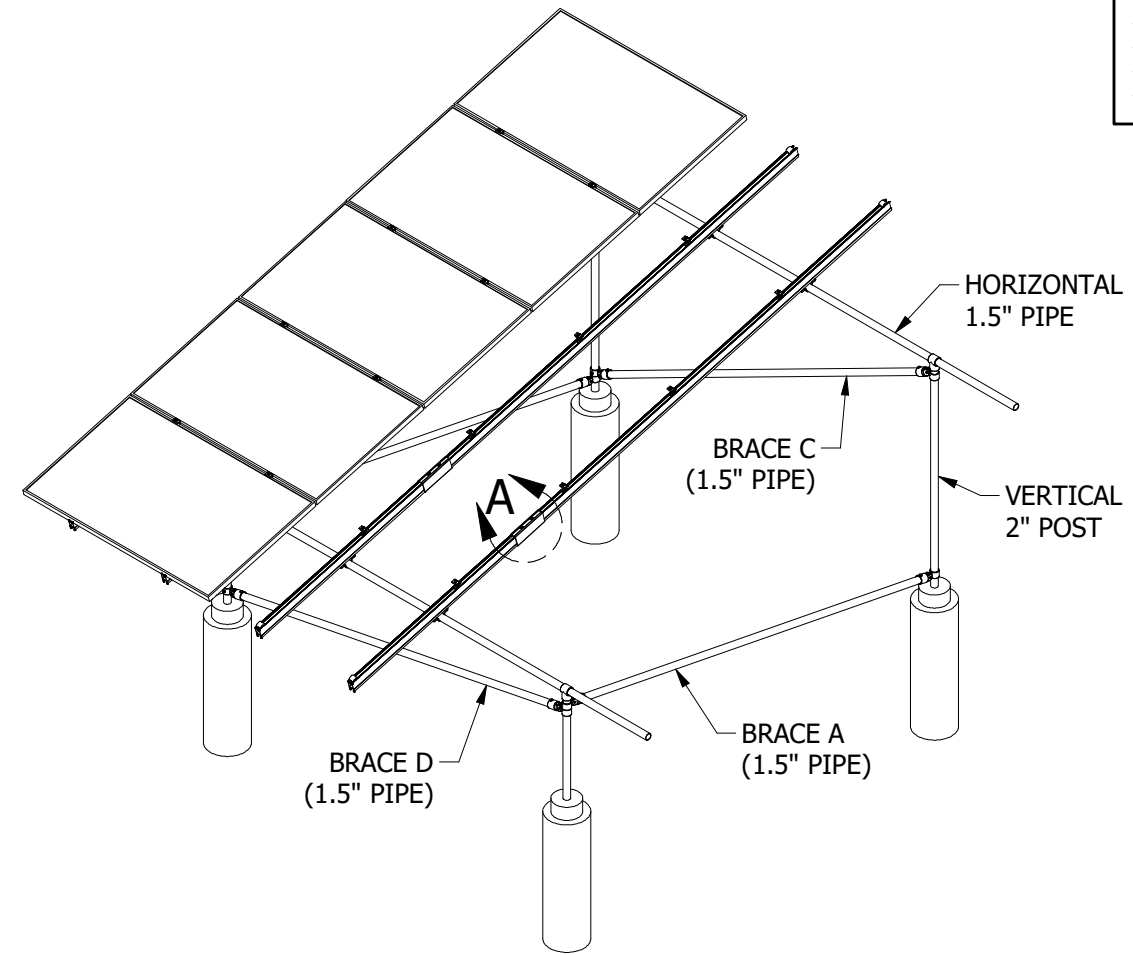

ISO OF RACKING ASSEMBLY

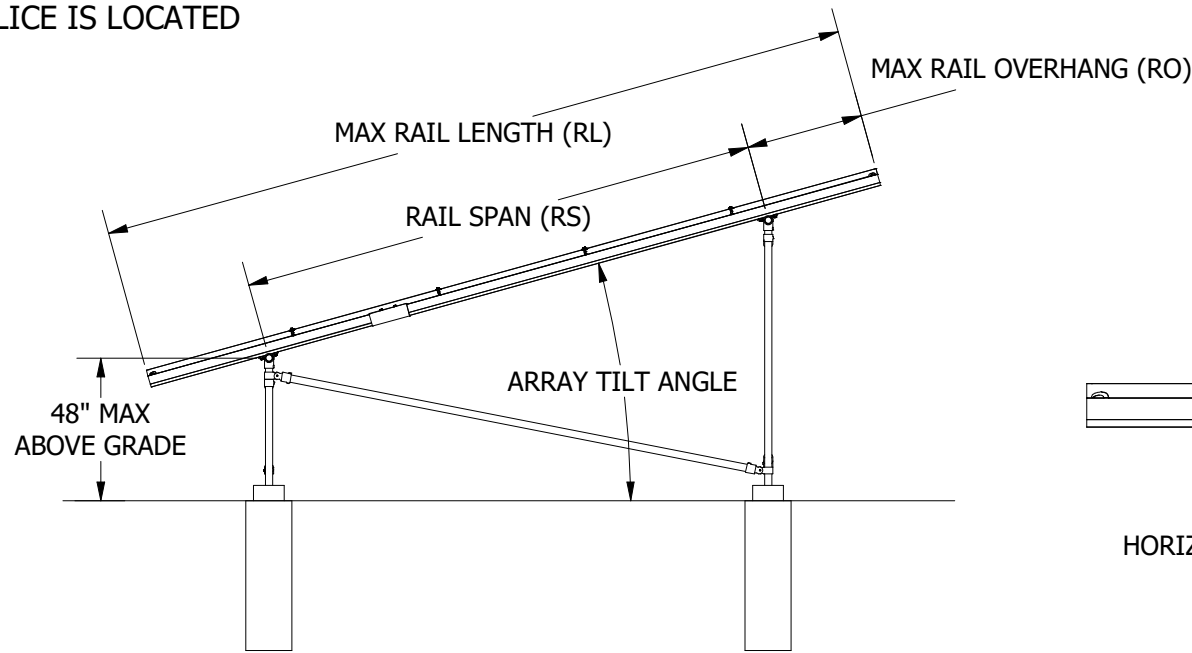

ARRAY SIDE VIEW



SPLICE LOCATION DETAIL