

COMPONENT DETAIL FOR THE SNAPRACK RL UNIVERSAL MOUNT

MOUNT MAY BE USED WITH FLASHTRACK (SEE SNR-DC-00363) OR SPEEDSEAL TRACK SHOWN IN THIS DETAIL

THE RL UNIVERSAL MOUNT UTILIZES A "CLAMP-SLEEVE" METHOD OF MODULE ATTACHMENT TO ALLOW A ROCK-IN INSTALLATION OF THE UP-SLOPE MODULE. SEE "CLAMP-SLEEVE ATTACHMENT" VIEW

RL UNIVERSAL MOUNTS BOND ACROSS PV ARRAY ROWS VIA THE RL UNIVERSAL BONDING CLIP

THE RL UNIVERSAL MOUNT PROVIDES A FIXED 3/4" GAP BETWEEN PV MODULE ROWS

FOR UNEVEN ROOF SURFACES EACH MOUNT HAS 1" OF LEVELING CAPABILITY IN 1/8" INCREMENTS.

REFER TO SNAPRACK INSTALLATION MANUAL FOR HARDWARE TORQUE SPECIFICATIONS

REVISION:			
1	11/8/2019	NEW DETAIL	BDP
2	7/7/2020	NU001109	DR
3	1/29/2021	RLU UPDATE	DR
B	7/13/2021	DC000497	DR

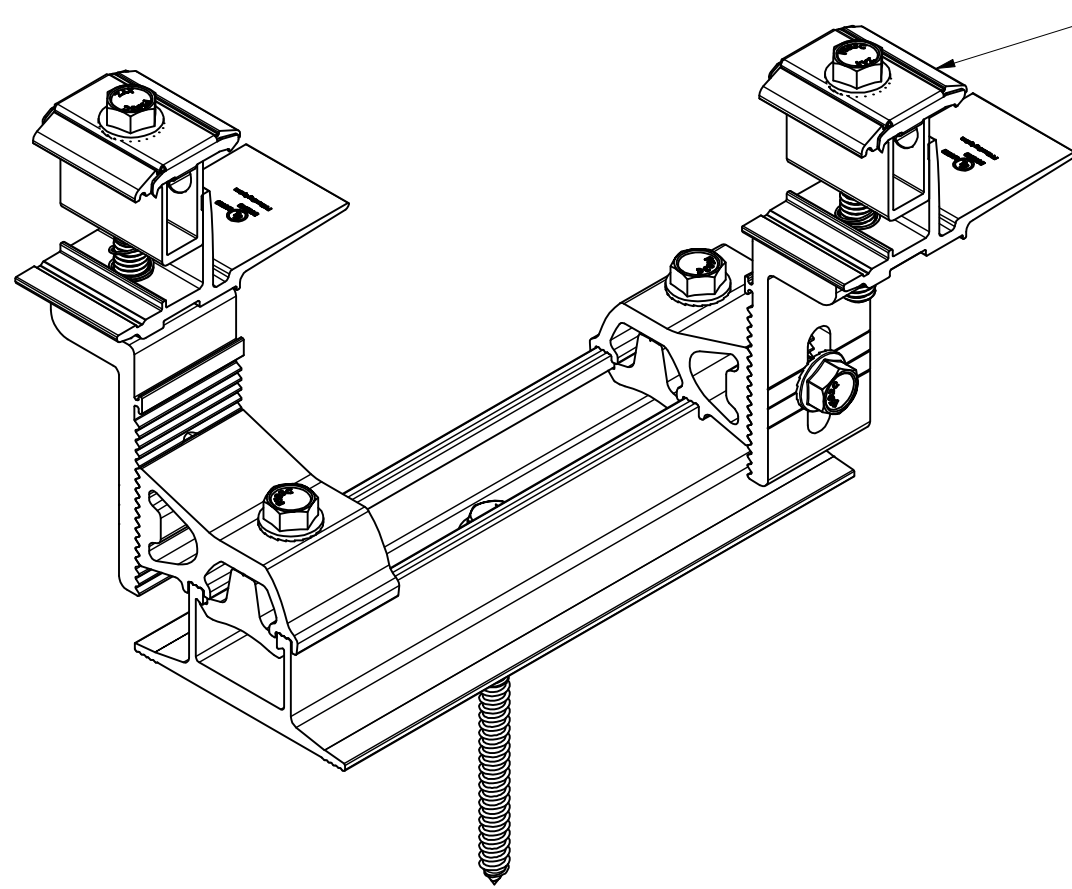

THE SNAPRACK RL UNIVERSAL MOUNT ATTACHES TO THE SNAPRACK SPEEDSEAL TRACK. IT CAN BE "FLIP-FLOPPED" IN THE SPEEDTRACK, AS SHOWN, TO REDUCE MODULE CANTILEVER AND ELIMINATE MOUNT-LINK INTERFERENCE

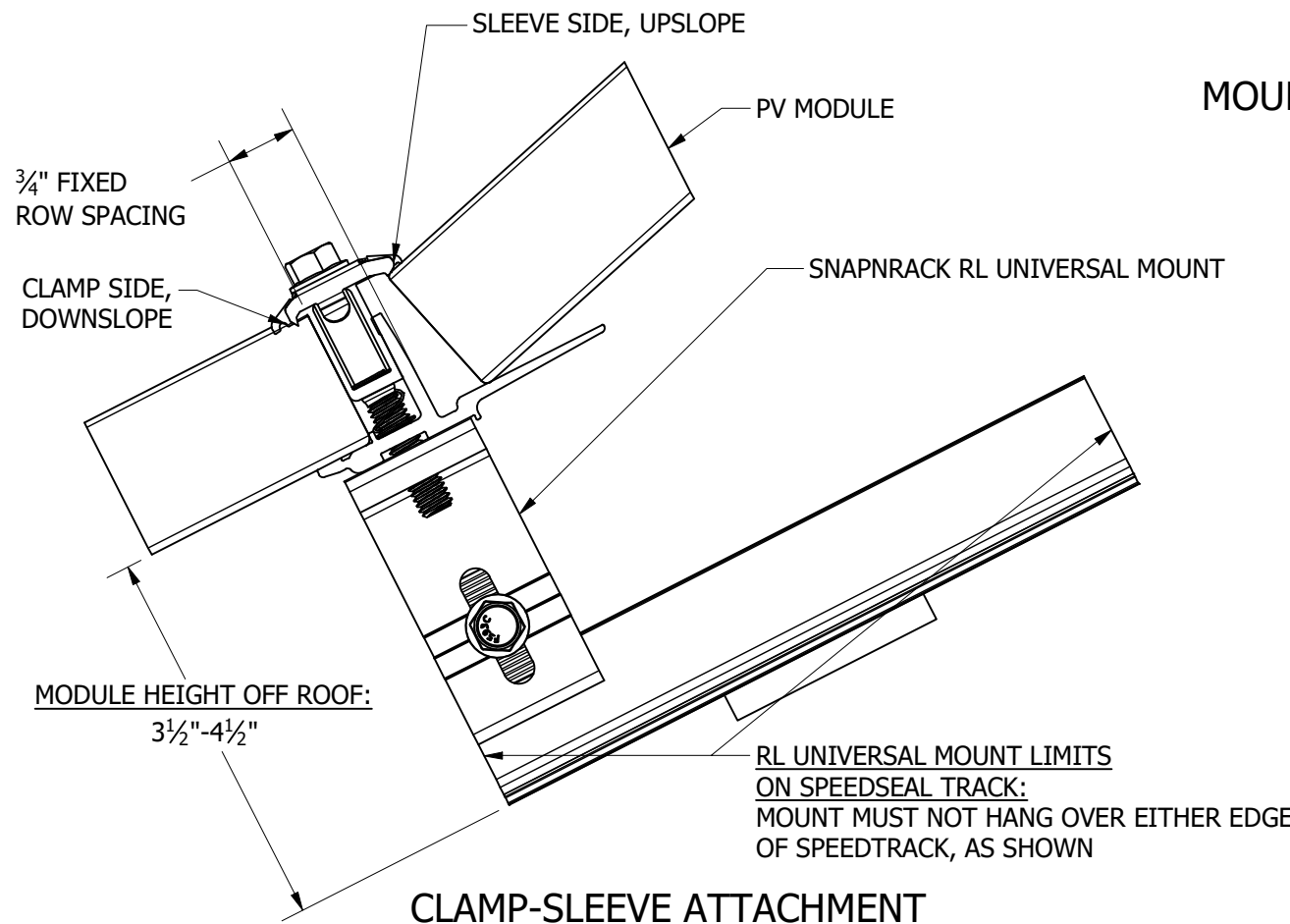
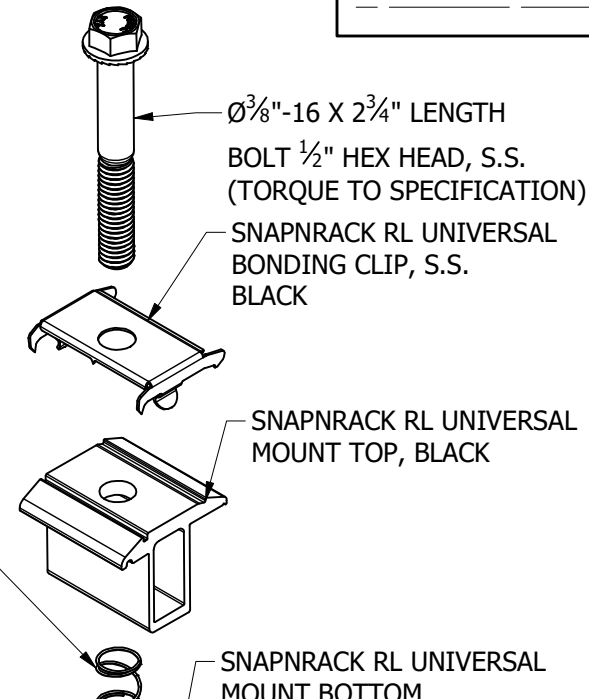

MOUNT "FLIP-FLOP" ABILITY

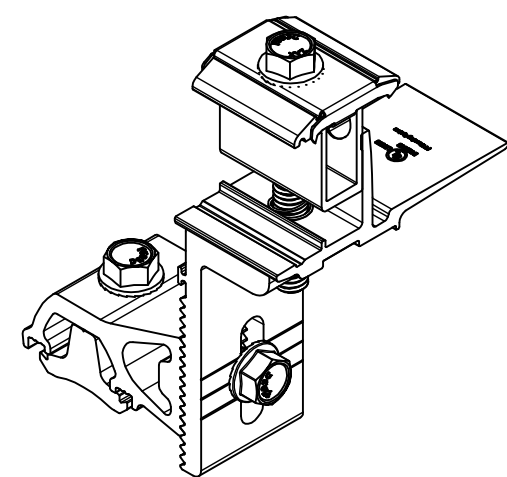

SNAPRACK RL UNIVERSAL MOUNT, ASSEMBLY

Ø5/16"-16 X 1" LENGTH BOLT, S.S. (TORQUE TO SPECIFICATION)

SNAPRACK RL UNIVERSAL RISER

SNAPRACK ROCK-IN CHANNEL NUT

COIL SPRING FOR Ø3/8" BOLT, S.S. (OPTIONAL)

SNAPRACK RL UNIVERSAL MOUNT, EXPLODED

Ø5/16"-16 X 3/4" LENGTH BOLT, S.S. (TORQUE TO SPECIFICATION)

Ø3/8"-16 X 2 3/4" LENGTH BOLT 1/2" HEX HEAD, S.S. (TORQUE TO SPECIFICATION)

SNAPRACK RL UNIVERSAL BONDING CLIP, S.S. BLACK

SNAPRACK RL UNIVERSAL MOUNT TOP, BLACK

SNAPRACK RL UNIVERSAL MOUNT BOTTOM

SNAPRACK RL UNIVERSAL LEVELER

RL UNIVERSAL MOUNT LIMITS ON SPEEDSEAL TRACK: MOUNT MUST NOT HANG OVER EITHER EDGE OF SPEEDTRACK, AS SHOWN

CLAMP-SLEEVE ATTACHMENT



Sunrun South LLC  
595 MARKET STREET, 29TH FLOOR • SAN FRANCISCO, CA 94105 USA  
PHONE (415) 580-6900 • FAX (415) 580-6902  
THE INFORMATION IN THIS DRAWING IS CONFIDENTIAL AND PROPRIETARY. ANY REPRODUCTION, DISCLOSURE, OR USE THEREOF IS PROHIBITED WITHOUT THE WRITTEN CONSENT OF SUNRUN SOUTH LLC.

DESIGNER: B.PETERSON  
DRAFTER: M.AFFENTRANGER  
APPROVED BY: B.PETERSON

SCALE: NTS  
DATE: 7/13/2021

DRAWING NUMBER: SNR-DC-00435

DESCRIPTION: RL UNIVERSAL, COMPONENT DETAIL, MOUNT WITH SPEEDSEAL TRACK

REV: B