

**SNAPNRACK RL UNIVERSAL SPEEDSEAL TRACK COMPOSITION
ROOF MOUNTING**

EMBED $\phi^{5/16}$ " LAG SCREW 2-1/2" INTO THE ROOF
STRUCTURAL MEMBER / RAFTER

FOR TORQUE SPECIFICATIONS SEE INSTALLATION MANUAL

MINIMUM WOOD GRADE OF STRUCTURAL MEMBER = SPF#2
MINIMUM SPECIFIC GRAVITY = 0.42

ALLOWABLE FASTENER UPLIFT = 820 LBS
ALLOWABLE FASTENER LATERAL = 250 LBS

MINIMUM FASTENER EDGE DISTANCE = 0.5"
MINIMUM FASTENER END DISTANCE = 2.2"

REVISION:			
1	11/11/2019	NEW DETAIL	BDP
2	7/7/2020	NU001109	DR
3	10/2/2020	AHJ UPDATE	DR
4	1/29/2021	RLU UPDATE	DR
B	7/13/2021	DC000497	DR

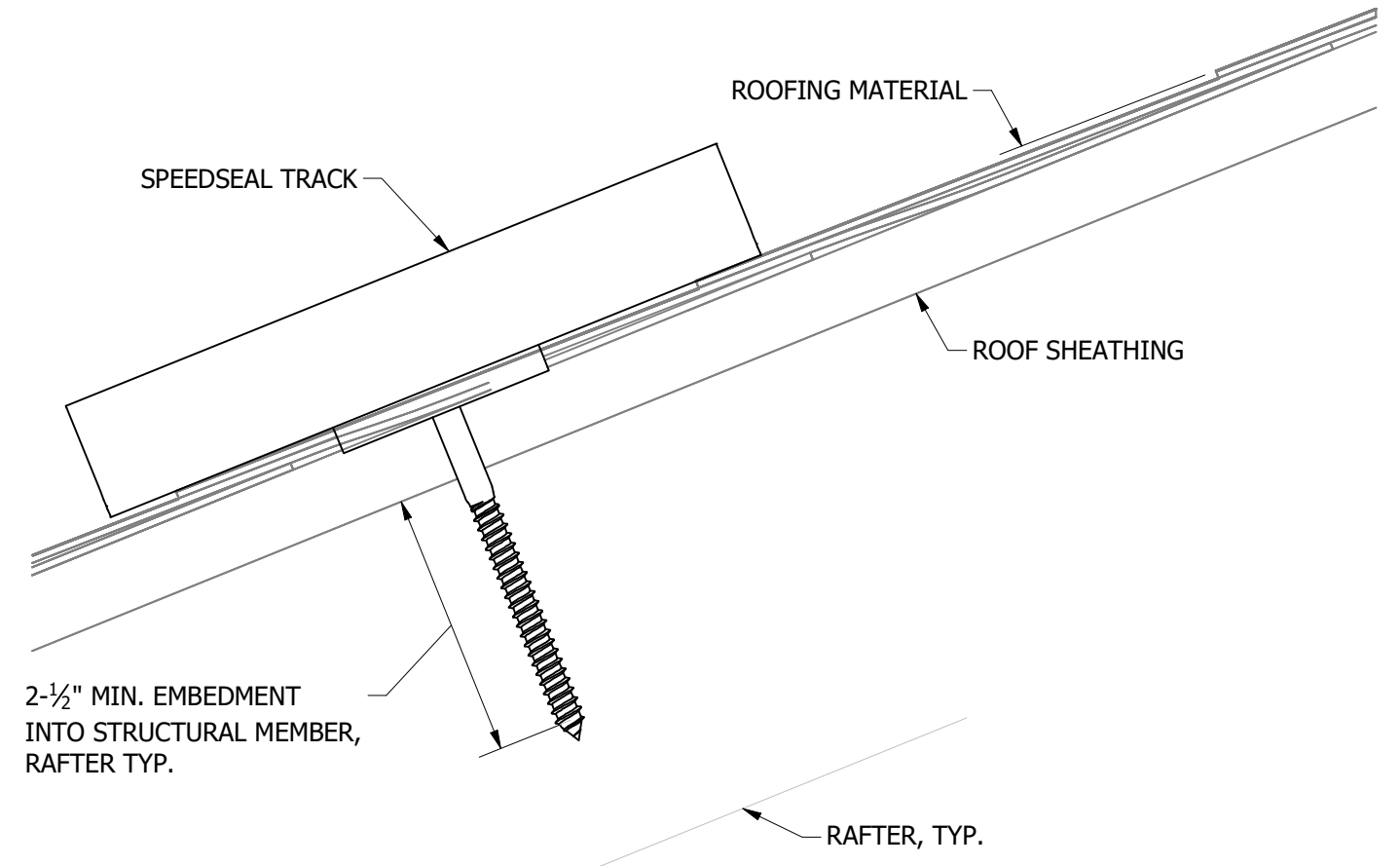
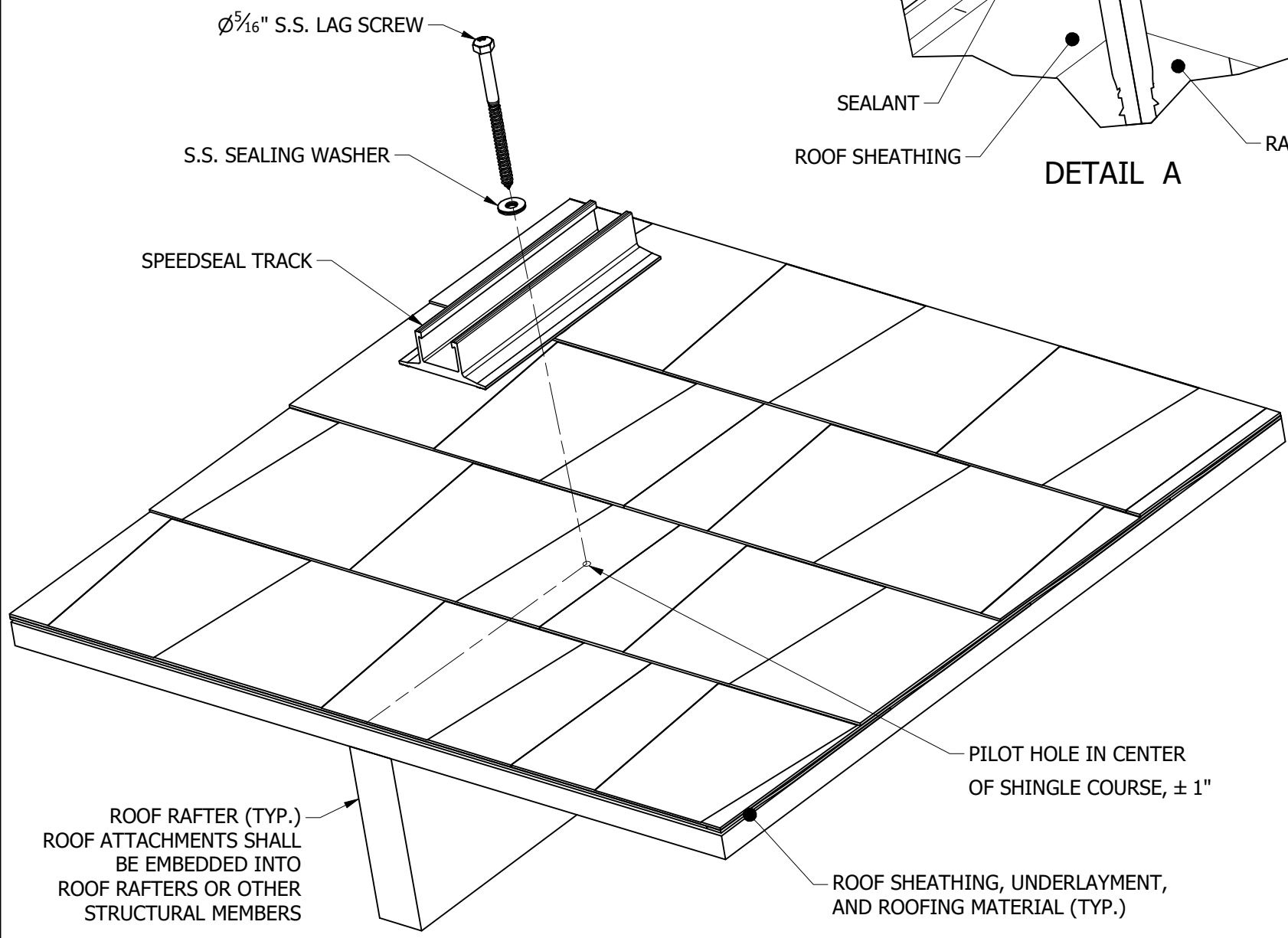
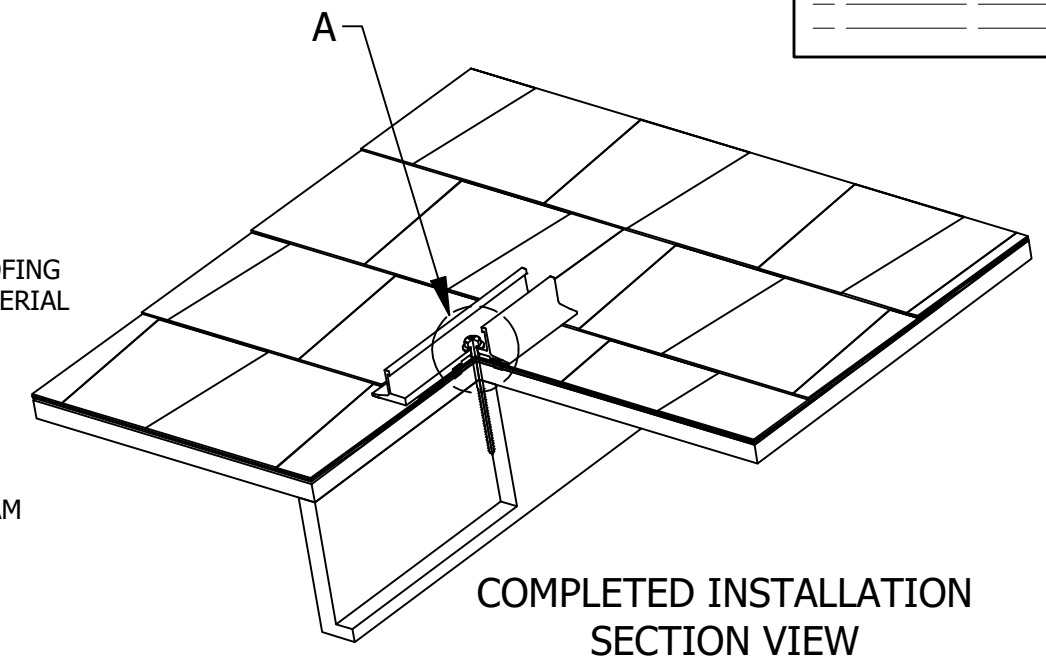
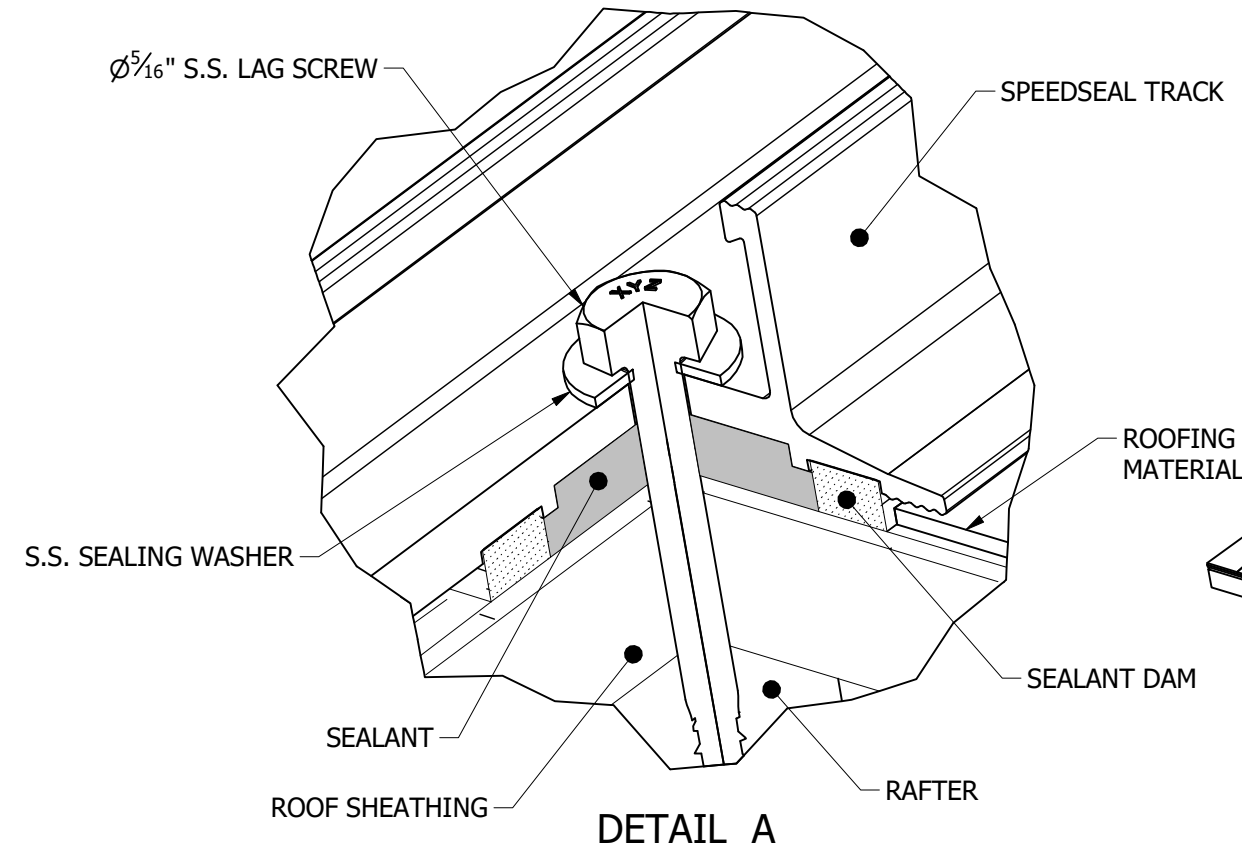

ROOF RAFTER (TYP.)
ROOF ATTACHMENTS SHALL
BE EMBEDDED INTO
ROOF RAFTERS OR OTHER
STRUCTURAL MEMBERS

PILOT HOLE IN CENTER
OF SHINGLE COURSE, ± 1"
ROOF SHEATHING, UNDERLAYMENT,
AND ROOFING MATERIAL (TYP.)

2-1/2" MIN. EMBEDMENT
INTO STRUCTURAL MEMBER,
RAFTER TYP.

COMPLETED INSTALLATION



Sunrun South LLC
595 MARKET STREET, 29TH FLOOR • SAN FRANCISCO, CA 94105 USA
PHONE (415) 580-6900 • FAX (415) 580-6902
THE INFORMATION IN THIS DRAWING IS CONFIDENTIAL AND PROPRIETARY. ANY
REPRODUCTION, DISCLOSURE, OR USE THEREOF IS PROHIBITED WITHOUT THE
WRITTEN CONSENT OF SUNRUN SOUTH LLC.

DESIGNER: B.PETERSON
DRAFTER: D.RYAN
APPROVED BY: W.ARBUCKLE

SCALE: NTS
DATE: 7/13/2021

DRAWING NUMBER:
SNR-DC-00436

DESCRIPTION:
RL UNIVERSAL, ATTACHMENT DETAIL,
SPEEDSEAL TRACK ON COMP

REV: **B**