

## Required Tools

- Socket Wrench
- Torque Wrench
- 1/2" Socket

## Materials Included

- ① (1) SnapNrack OmniLug™ Bonding Bracket
- ② (1) SnapNrack Bonding Channel Nut
- ③ (1) SEMS Screw, HEX, 5-16"-18 X 1¼", 7/8" OD Conical Washer, Tooth, SS

Technical Specifications	
Material	Stainless Steel body, Stainless Steel Hardware
Certifications	UL 2703. Listed for use with SnapNrack Ultra Rail, S200, RL Universal and MightyMount™ Systems.
Grounding Conductors	Approved Grounding Conductors: 12-6 AWG solid copper wire, 10-8 AWG stranded copper wire

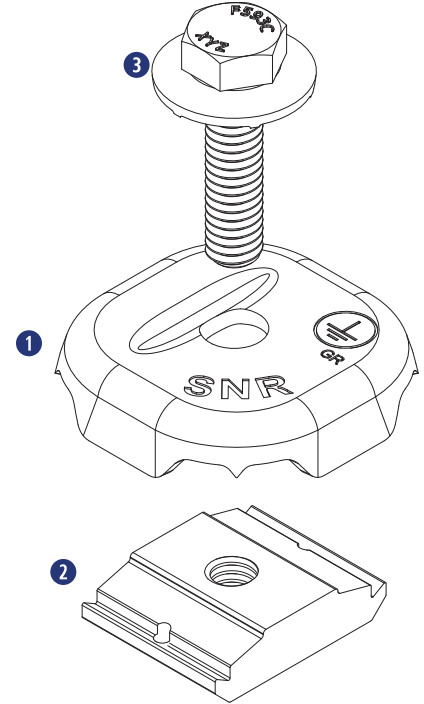

## Applications

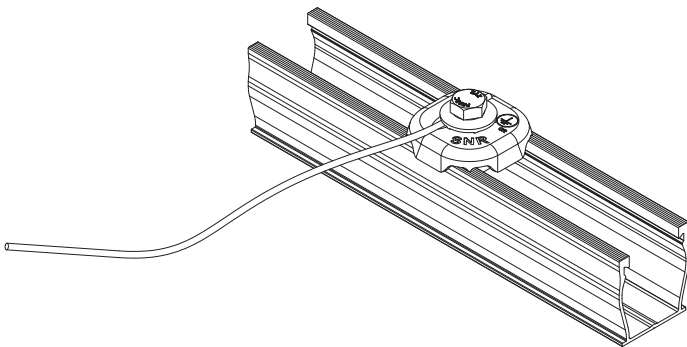

OmniLug™-Ground Lug on Ultra Rail

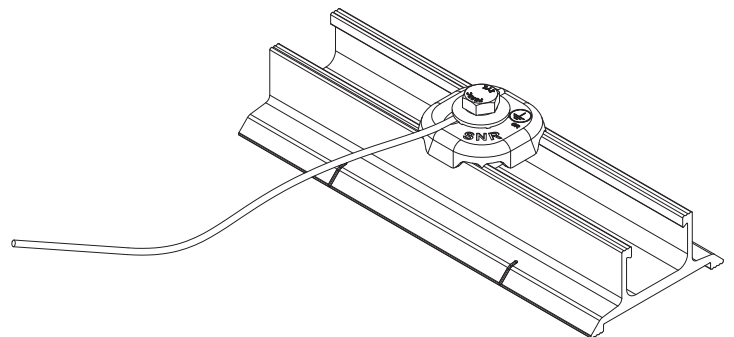

OmniLug™-Ground Lug on Track

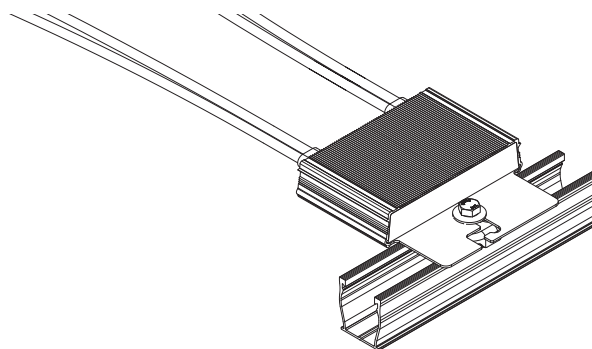

OmniLug™-MLPE Attachment on Ultra Rail

## OMNILUG™ - GROUND LUG INSTALLATION INSTRUCTIONS

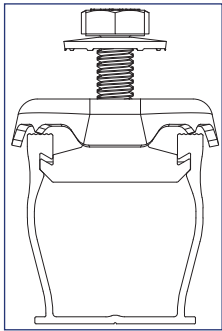
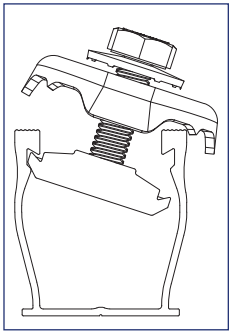

1) Snap the SnapNrack OmniLug into the rail channel or track.

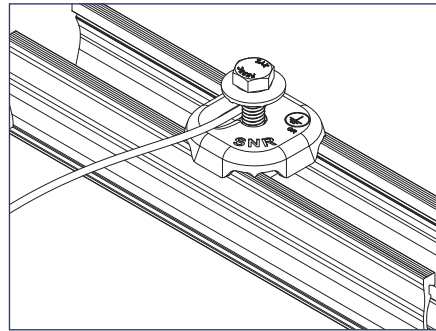

2) Place the grounding conductor into the slot on the Bonding Bracket underneath the conical washer on the SEMS bolt.

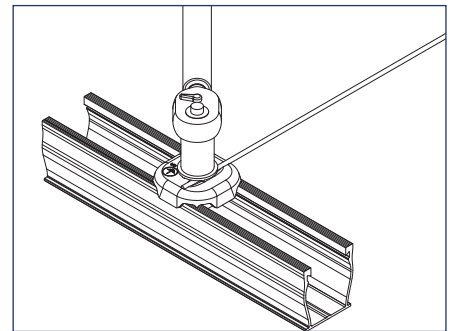

3) Holding the grounding conductor in place, tighten the mounting bolt to 10.8 lb-ft (130 lb-in.)

### Install Note:

Install on one rail per module row on an Ultra Rail system.

Groove in Bonding Bracket may be oriented either parallel to the rail or perpendicular to it.

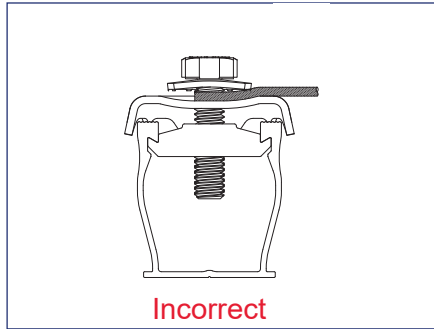
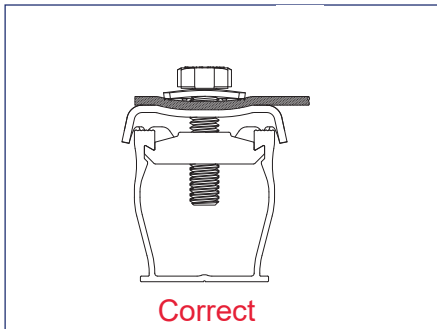

4) Grounding conductor must extend beyond the entire conical washer to assure proper bonding

## OMNILUG™ - MLPE ATTACHMENT INSTALLATION INSTRUCTIONS

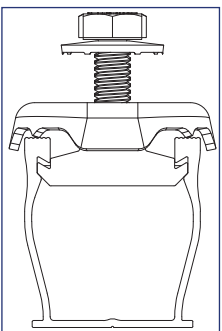
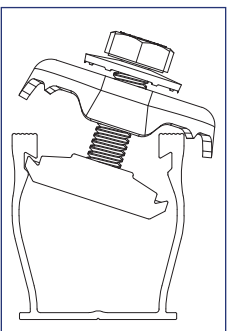

1) Snap the SnapNrack OmniLug™ into the rail channel at the desired location.

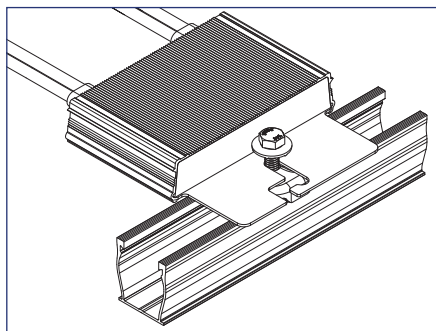

2) Place the mounting plate chassis of the MLPE device on the Bonding Bracket underneath the conical washer on the SEMS bolt.

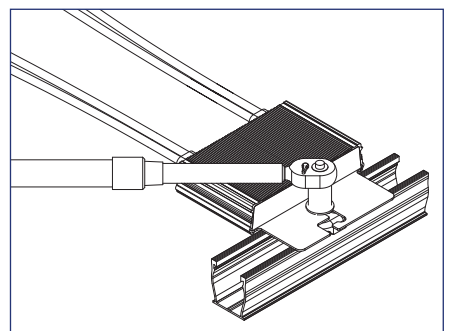

3) Holding the MLPE device in place, tighten the mounting bolt with a socket wrench or a torque wrench to 10.8 lb-ft (130 lb-in.)

### Install Note:

Groove in Bonding Bracket may be oriented parallel or perpendicular to rail.