

DESCRIPTION:  
**SNAPNRACK, TDS, UNIVERSAL CONDUIT  
 MOUNT, L FOOT**

DOC NUMBER:  
 SNR-DC-01432

**SnapNrack®**

PART NUMBER(S):

242-10051

DRAWN BY:  
 mwatkins

REV:

**A**

DATE:

10/2/2024

SNR SOLAR LLC

775 FIERO LANE, SUITE 200  
 SAN LUIS OBISPO, CA 93401 USA  
 EMAIL: CONTACT@SNAPNRACK.COM

THE INFORMATION IN THIS DRAWING IS CONFIDENTIAL AND PROPRIETARY. ANY  
 REPRODUCTION, DISCLOSURE, OR USE THEREOF IS PROHIBITED WITHOUT THE  
 WRITTEN CONSENT OF SNR SOLAR LLC.

UNITS: IN, LB, DEG [MM, KG, DEG]

SHEET: 1:2

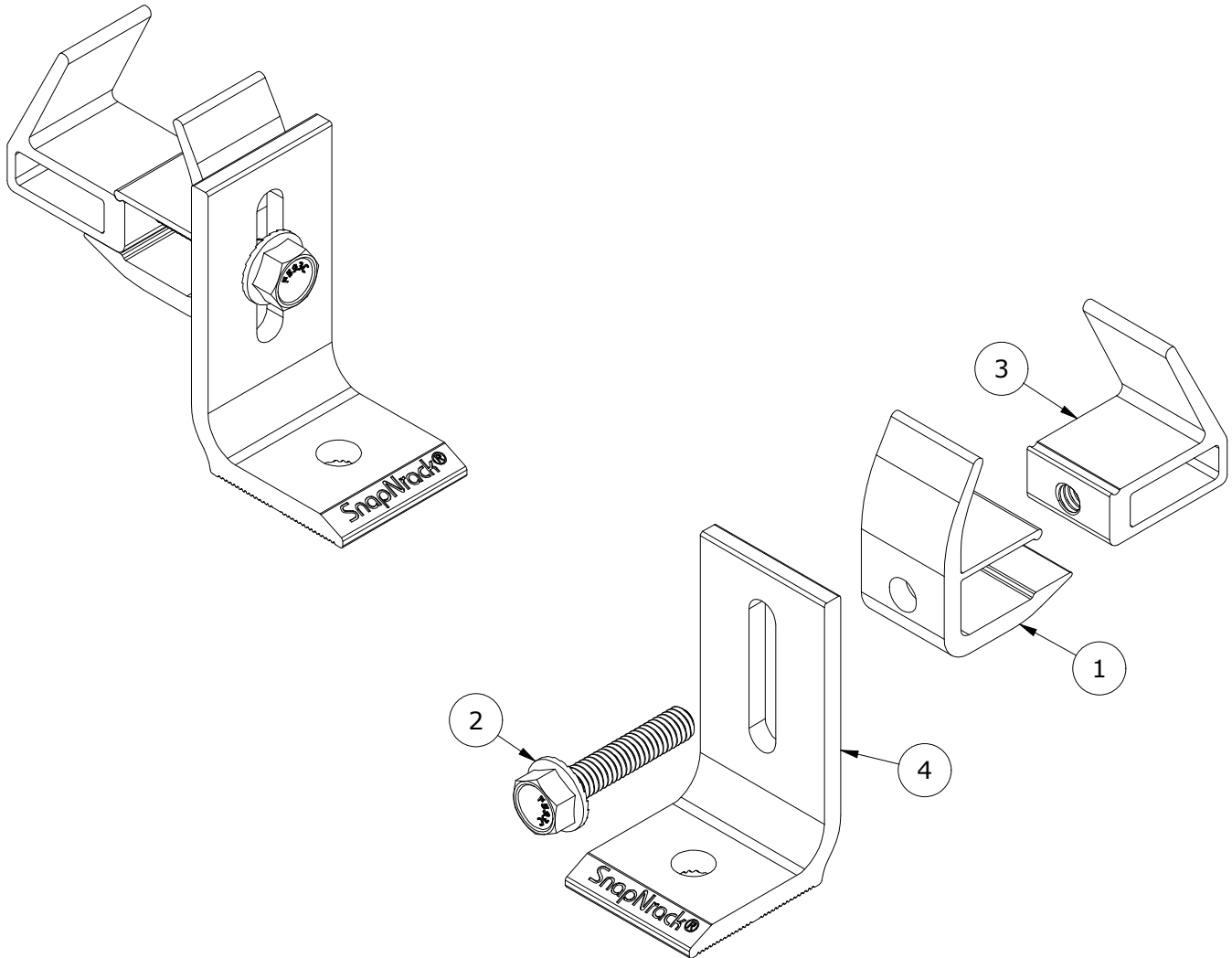

**PARTS LIST**

ITEM	QTY	DESCRIPTION
1	1	SNAPNRACK, UNIVERSAL CONDUIT CLAMP, THRU
2	1	BOLT, FLANGE SERRATED, 5/16IN-18 X 1-1/2IN, SS
3	1	SNAPNRACK, UNIVERSAL CONDUIT CLAMP, TAPPED
4	1	SNAPNRACK, AP90 L FOOT II, SILVER

**COMPATIBLE WITH THE FOLLOWING  
 CONDUIT TYPES AND SIZES:**

- 3/4" EMT
- 1" EMT
- 3/4" PVC
- 1" PVC

MATERIALS: 6000 SERIES ALUMINUM, STAINLESS STEEL

DESIGN LOAD (LBS): N/A

ULTIMATE LOAD (LBS): N/A

TORQUE SPECIFICATION: 5 FT-LBS

CERTIFICATION: UL 2239

WEIGHT (LBS): 0.29

DESCRIPTION:  
SNAPNRACK, TDS, UNIVERSAL CONDUIT  
MOUNT, L FOOT

DOC NUMBER:  
SNR-DC-01432

SnapNrack®

PART NUMBER(S):

242-10051

DRAWN BY:  
mwatkins

REV:

A

DATE:

10/2/2024

SNR SOLAR LLC

775 FIERO LANE, SUITE 200  
SAN LUIS OBISPO, CA 93401 USA  
EMAIL: CONTACT@SNAPNRACK.COM

THE INFORMATION IN THIS DRAWING IS CONFIDENTIAL AND PROPRIETARY. ANY  
REPRODUCTION, DISCLOSURE, OR USE THEREOF IS PROHIBITED WITHOUT THE  
WRITTEN CONSENT OF SNR SOLAR LLC.

UNITS: IN, LB, DEG [MM, KG, DEG]

SHEET: 2:2

