

DESCRIPTION:
**SNAPNRACK, TDS, UNIVERSAL CONDUIT
 MOUNT, L FOOT**

DOC NUMBER:
 SNR-DC-01432

SnapNrack®

PART NUMBER(S):

242-10051

DRAWN BY:
 mwatkins

REV:

B

DATE:

1/7/2025

SNR SOLAR LLC

775 FIERO LANE, SUITE 200
 SAN LUIS OBISPO, CA 93401 USA
 EMAIL: CONTACT@SNAPNRACK.COM

THE INFORMATION IN THIS DRAWING IS CONFIDENTIAL AND PROPRIETARY. ANY
 REPRODUCTION, DISCLOSURE, OR USE THEREOF IS PROHIBITED WITHOUT THE
 WRITTEN CONSENT OF SNR SOLAR LLC.

UNITS: IN, LB, DEG [MM, KG, DEG]

SHEET: 1:2

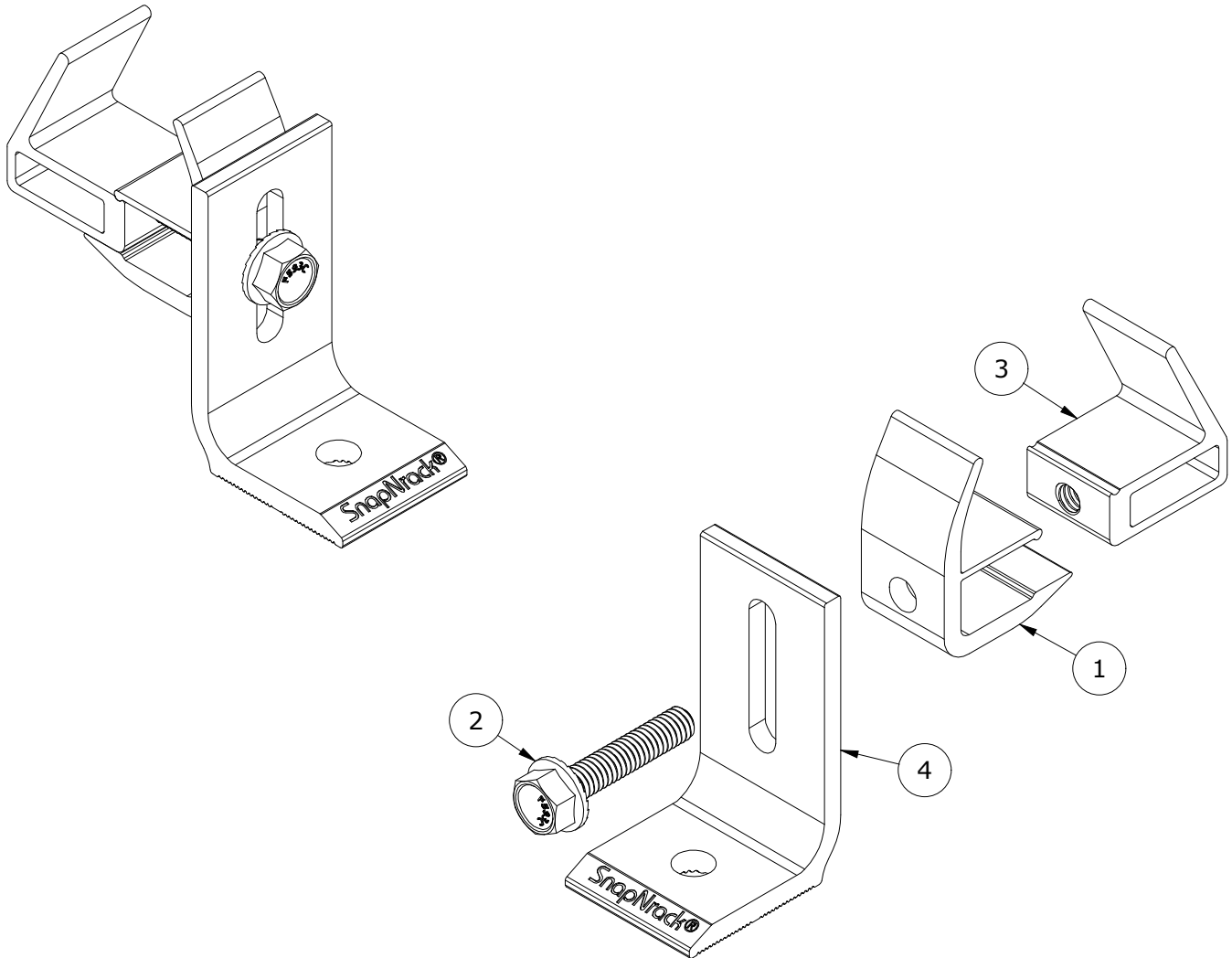

PARTS LIST

ITEM	QTY	DESCRIPTION
1	1	SNAPNRACK, UNIVERSAL CONDUIT CLAMP, THRU
2	1	BOLT, FLANGE SERRATED, 5/16IN-18 X 1-1/2IN, SS
3	1	SNAPNRACK, UNIVERSAL CONDUIT CLAMP, TAPPED, L FOOT
4	1	SNAPNRACK, AP90 L FOOT II, SILVER

COMPATIBLE WITH THE FOLLOWING
 CONDUIT TYPES AND SIZES:

- 3/4" EMT
- 1" EMT
- 3/4" PVC
- 1" PVC

SUITABLE FOR WET LOCATIONS

MATERIALS: 6000 SERIES ALUMINUM, STAINLESS STEEL

DESIGN LOAD (LBS): 50

ULTIMATE LOAD (LBS): N/A

TORQUE SPECIFICATION: 5 FT-LBS

CERTIFICATION: UL 2239, FILE E543241

WEIGHT (LBS): 0.29

DESCRIPTION:
SNAPRACK, TDS, UNIVERSAL CONDUIT
MOUNT, L FOOT

DOC NUMBER:
SNR-DC-01432

SnapNrack®

PART NUMBER(S):

242-10051

DRAWN BY:
mwatkins

REV:

B

DATE:

1/7/2025

SNR SOLAR LLC

775 FIERO LANE, SUITE 200
SAN LUIS OBISPO, CA 93401 USA
EMAIL: CONTACT@SNAPNRACK.COM

THE INFORMATION IN THIS DRAWING IS CONFIDENTIAL AND PROPRIETARY. ANY
REPRODUCTION, DISCLOSURE, OR USE THEREOF IS PROHIBITED WITHOUT THE
WRITTEN CONSENT OF SNR SOLAR LLC.

UNITS: IN, LB, DEG [MM, KG, DEG]

SHEET: 2:2

