

DESCRIPTION:
**SNAPNRACK, TDS, TOPSPEED UNIVERSAL,
 MOUNT**

DOC NUMBER:
 SNR-DC-01381

SnapNrack®

PART NUMBER(S):
 242-02155

DRAWN BY:
 M.AFFENTRANGER

SNR SOLAR LLC

REV: **C** DATE:
 11/22/2024

775 FIERO LANE, SUITE 200
 SAN LUIS OBISPO, CA 93401 USA
 EMAIL: CONTACT@SNAPNRACK.COM

THE INFORMATION IN THIS DRAWING IS CONFIDENTIAL AND PROPRIETARY. ANY REPRODUCTION, DISCLOSURE, OR USE THEREOF IS PROHIBITED WITHOUT THE WRITTEN CONSENT OF SUNRUN SOUTH LLC.

UNITS: IN, LB, DEG [MM, KG, DEG] SHEET: 1:2

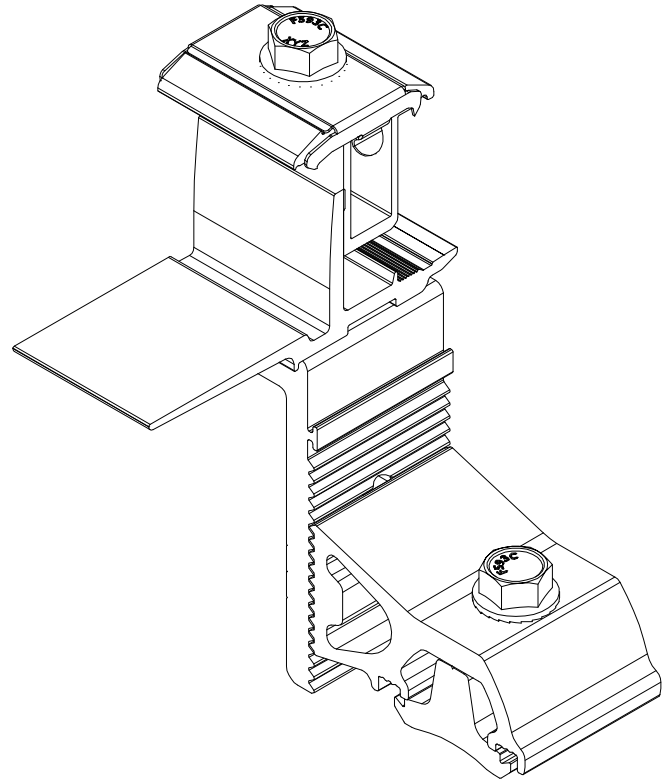
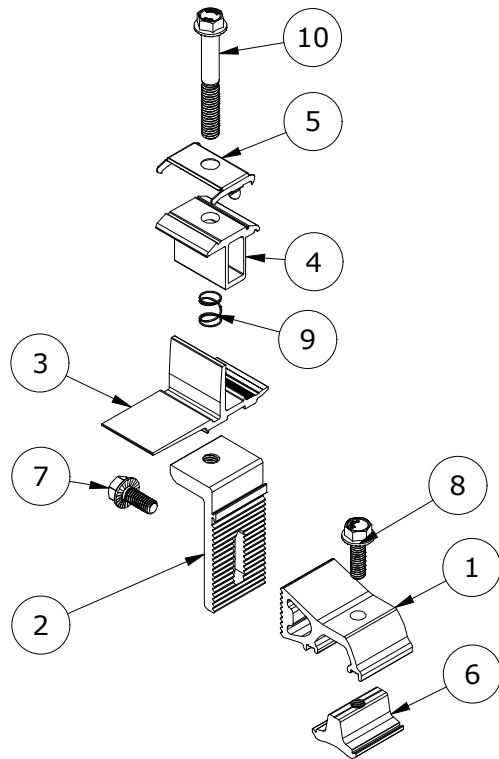

PARTS LIST

ITEM	QTY	DESCRIPTION
1	1	SNAPNRACK, TOPSPEED UNIVERSAL, RISER, MILL
2	1	SNAPNRACK, TOPSPEED UNIVERSAL, LEVELER, MILL
3	1	SNAPNRACK, TOPSPEED UNIVERSAL, MOUNT BOTTOM, MILL
4	1	SNAPNRACK, TOPSPEED UNIVERSAL, MOUNT TOP, BLACK
5	1	SNAPNRACK, TOPSPEED UNIVERSAL, BONDING CLIP
6	1	SNAPNRACK, DROP IN/ROCK IN CHANNEL NUT
7	1	BOLT, FLANGE, 5/16IN-18 X 3/4IN, CLEAR, SS
8	1	BOLT, FLANGE, SERRATED, 5/16IN-18 X 1IN, SS
9	1	SNAPNRACK, TOPSPEED UNIVERSAL, MOUNT SPRING, SS
10	1	BOLT, FLANGE, SERRATED, 3/8IN-16 X 2-3/4IN, 1/2IN TRIM HEAD, 1.2IN THREAD, BLACK, SS

MATERIALS: 6000 SERIES ALUMINUM, STAINLESS STEEL

DESIGN LOAD (LBS): 623 UP, 674 DOWN, 505 SIDE

ULTIMATE LOAD (LBS): N/A

TORQUE SPECIFICATION: 12 FT-LBS

CERTIFICATION: UL 2703, FILE E359313

WEIGHT (LBS): 0.73