

DESCRIPTION:
SNAPNRACK, ULTRA RAIL MID CLAMP (USA)

DOC NUMBER:
 SNR-DC-01439

SnapNrack®

PART NUMBER(S):
 242-02071-USA

DRAWN BY:
 M.WATKINS

SNR SOLAR LLC

775 FIERO LANE, SUITE 200
 SAN LUIS OBISPO, CA 93401 USA
 EMAIL: CONTACT@SNAPNRACK.COM

REV: **A** DATE: 11/12/2024

THE INFORMATION IN THIS DRAWING IS CONFIDENTIAL AND PROPRIETARY. ANY REPRODUCTION, DISCLOSURE, OR USE THEREOF IS PROHIBITED WITHOUT THE WRITTEN CONSENT OF SNR SOLAR LLC.

UNITS: IN, LB, DEG [MM, KG, DEG] SHEET: 1:2

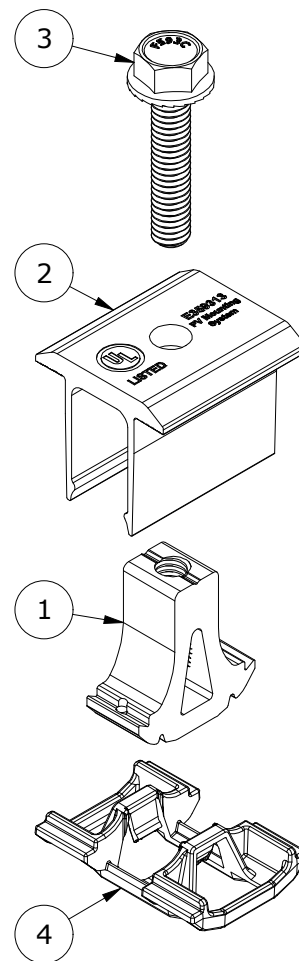
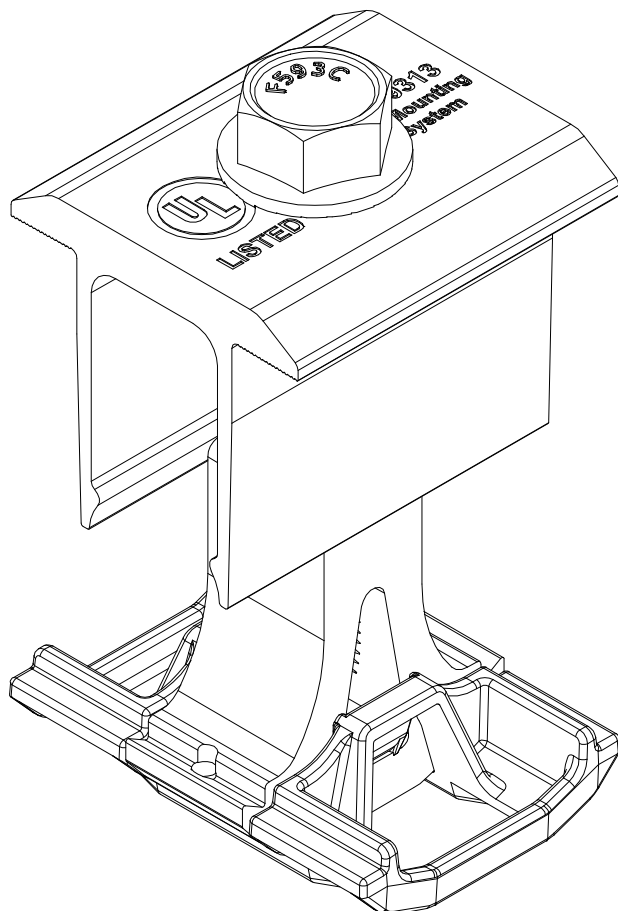

PARTS LIST		
ITEM	QTY	DESCRIPTION
1	1	SNAPNRACK, ULTRA RAIL MID CLAMP, KEYED BASE
2	1	SNAPNRACK, ULTRA RAIL MID CLAMP, TOP
3	1	BOLT, FLANGE SERRATED, 5/16IN-18 X 1-1/2IN, SS
4	1	SNAPNRACK, ULTRA RAIL MID CLAMP, EXTENSION

NOTE:
 CLAMPS FIT 30-46MM THICK MODULE FRAMES

MATERIALS:	6000 SERIES ALUMINUM, STAINLESS STEEL, PLASTIC
DESIGN LOAD (LBS):	855
ULTIMATE LOAD (LBS):	2000
TORQUE SPECIFICATION:	16 FT-LBS
CERTIFICATION:	UL 2703, FILE E359313, DOMESTIC CONTENT COMPLIANT
WEIGHT (LBS):	0.16

DESCRIPTION:
SNAPNRACK, ULTRA RAIL MID CLAMP (USA)

DOC NUMBER:
SNR-DC-01439

SnapNrack®

PART NUMBER(S):
242-02071-USA

DRAWN BY:
M.WATKINS

SNR SOLAR LLC
775 FIERO LANE, SUITE 200
SAN LUIS OBISPO, CA 93401 USA
EMAIL: CONTACT@SNAPNRACK.COM
THE INFORMATION IN THIS DRAWING IS CONFIDENTIAL AND PROPRIETARY. ANY REPRODUCTION, DISCLOSURE, OR USE THEREOF IS PROHIBITED WITHOUT THE WRITTEN CONSENT OF SNR SOLAR LLC.

UNITS: IN, LB, DEG [MM, KG, DEG]

SHEET: 2:2

REV: **A** DATE: 11/12/2024

