

DESCRIPTION:
**SNAPNRACK, TDS, UNIVERSAL SKIRTRAIL
 SPACERS (USA)**

DOC NUMBER:
 SNR-DC-01364

SnapNrack®

PART NUMBER(S):
 232-02494-USA, 232-02495-USA, 232-02496-USA,
 232-02497-USA, 232-02532-USA

DRAWN BY:
 M.AFFENTRANGER

SNR SOLAR LLC

775 FIERO LANE, SUITE 200
 SAN LUIS OBISPO, CA 93401 USA
 EMAIL: CONTACT@SNAPNRACK.COM

REV: DATE:

A

11/22/2024

THE INFORMATION IN THIS DRAWING IS CONFIDENTIAL AND PROPRIETARY. ANY
 REPRODUCTION, DISCLOSURE, OR USE THEREOF IS PROHIBITED WITHOUT THE
 WRITTEN CONSENT OF SUNRUN SOUTH LLC.

UNITS: IN, LB, DEG [MM, KG, DEG]

SHEET: 1:1

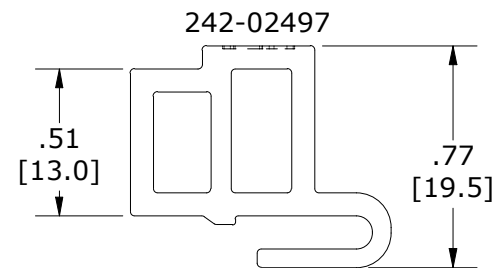
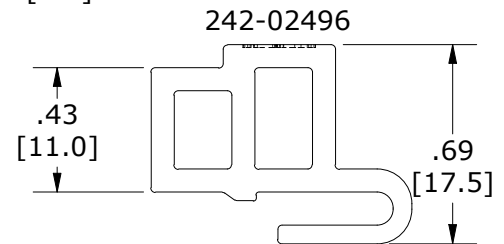
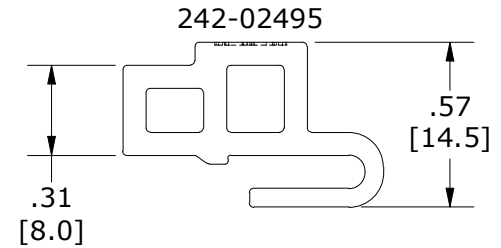
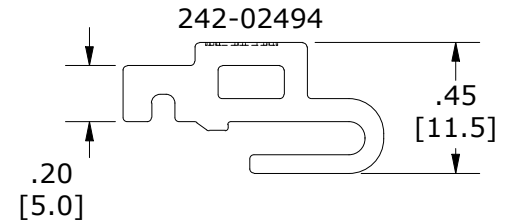
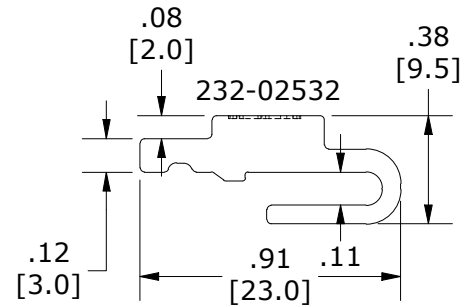
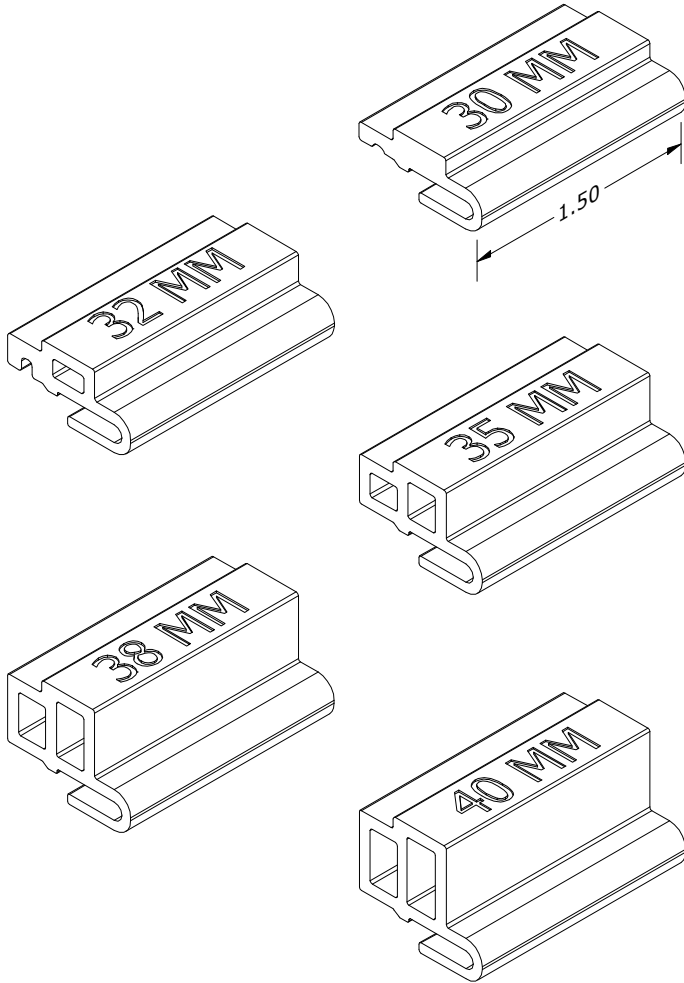

PROPERTIES

SKU	MODULE FRAME SIZE	COLOR
232-02532-USA	30 MM	GREEN
232-02494-USA	32 MM	GOLD
232-02495-USA	35 MM	BLUE
232-02496-USA	38 MM	BLACK
232-02497-USA	40 MM	SILVER/CLEAR

MATERIALS: 6000 SERIES ALUMINUM

DESIGN LOAD (LBS): N/A

ULTIMATE LOAD (LBS): N/A

TORQUE SPECIFICATION: N/A FT-LBS

CERTIFICATION: UL 2703, FILE E359313; DOMESTIC CONTENT COMPLIANT

WEIGHT (LBS): 0.02 - 0.04