

DESCRIPTION:  
SNAPNRACK, TDS, UNIVERSAL LINK (USA)

DOC NUMBER:  
SNR-DC-01447

SnapNrack®

PART NUMBER(S):  
242-02156-USA

DRAWN BY:  
M.AFFENTRANGER

SNR SOLAR LLC

REV: DATE:

775 FIERO LANE, SUITE 200  
SAN LUIS OBISPO, CA 93401 USA  
EMAIL: CONTACT@SNAPNRACK.COM

UNITS: IN, LB, DEG [MM, KG, DEG] SHEET: 1:1

A 11/22/2024

THE INFORMATION IN THIS DRAWING IS CONFIDENTIAL AND PROPRIETARY. ANY REPRODUCTION, DISCLOSURE, OR USE THEREOF IS PROHIBITED WITHOUT THE WRITTEN CONSENT OF SUNRUN SOUTH LLC.

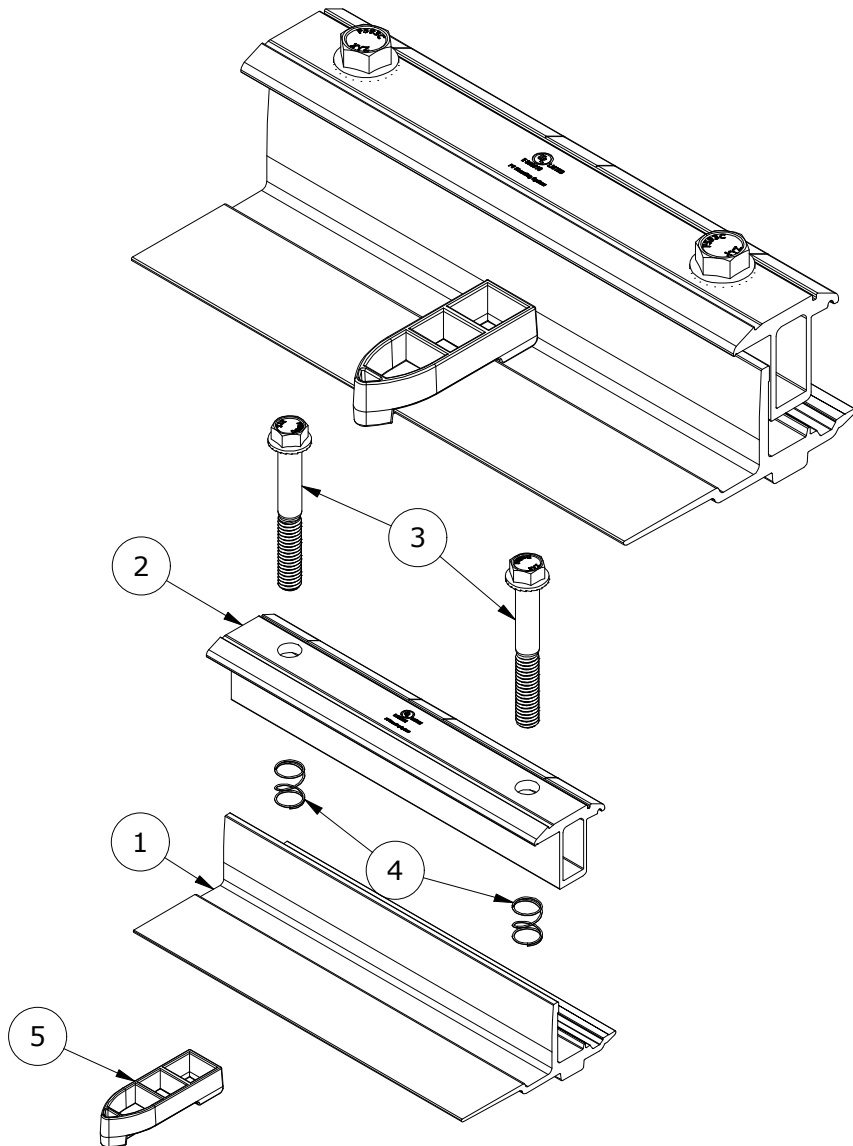
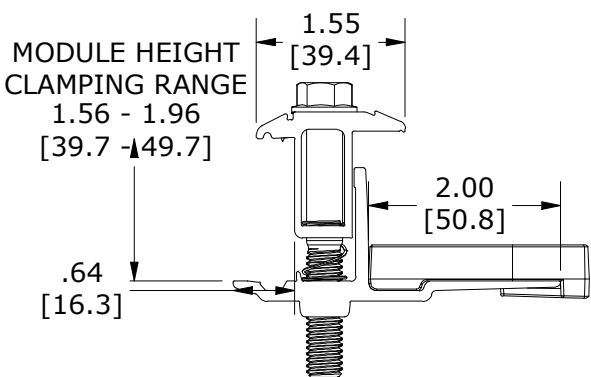
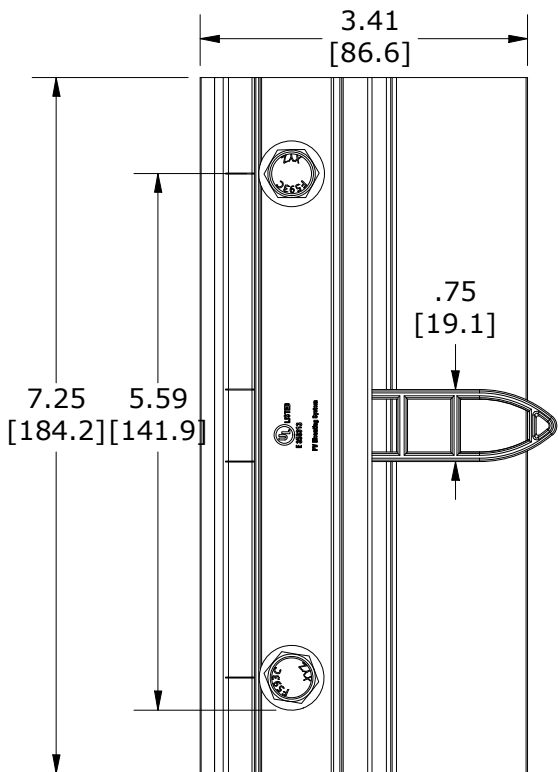

PARTS LIST

| ITEM | QTY | DESCRIPTION  |
|------|-----|--|
| 1    | 1   | SNAPNRACK, UNIVERSAL LINK BOTTOM, MILL   |
| 2    | 1   | SNAPNRACK, UNIVERSAL LINK TOP, BONDING, BLACK  |
| 3    | 2   | BOLT, FLANGE, SERRATED, 3/8IN-16 X 2-3/4IN, 1/2IN TRIM HEAD, 1.2IN THREAD, BLACK, SS |
| 4    | 2   | SNAPNRACK, TOPSPEED UNIVERSAL, MOUNT SPRING, SS                                      |
| 5    | 1   | SNAPNRACK, UNIVERSAL LINK, COLUMN SPACER   |

MATERIALS: 6000 SERIES ALUMINUM, STAINLESS STEEL, POLYCARBONATE

DESIGN LOAD (LBS): N/A

ULTIMATE LOAD (LBS): N/A

TORQUE SPECIFICATION: 12 FT-LBS

CERTIFICATION: UL 2703, FILE E359313; DOMESTIC CONTENT COMPLIANT

WEIGHT (LBS): 1.03