

DESCRIPTION:
SNAPNRACK, TDS, UNIVERSAL END CLAMP (USA)

DOC NUMBER:
 SNR-DC-01450

SnapNrack®

PART NUMBER(S):
 242-02215-USA

DRAWN BY:
 H.WULFEKOETTER

SNR SOLAR LLC
 775 FIERO LANE, SUITE 200
 SAN LUIS OBISPO, CA 93401 USA
 EMAIL: CONTACT@SNAPNRACK.COM

UNITS: IN, LB, DEG [MM, KG, DEG] SHEET: 1:2

REV: DATE:
A 11/21/2024

THE INFORMATION IN THIS DRAWING IS CONFIDENTIAL AND PROPRIETARY. ANY REPRODUCTION, DISCLOSURE, OR USE THEREOF IS PROHIBITED WITHOUT THE WRITTEN CONSENT OF SUNRUN SOUTH LLC.

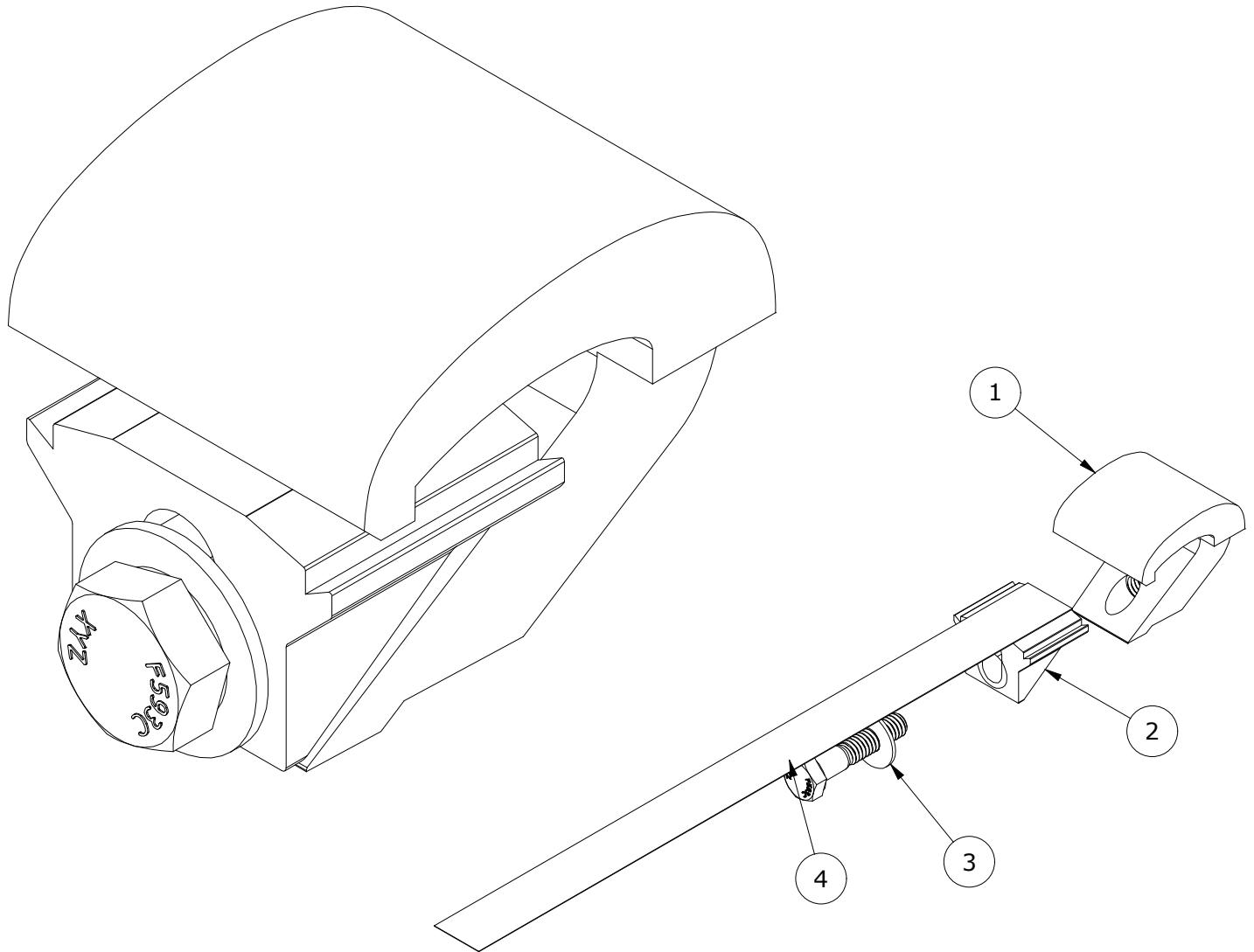

PARTS LIST		
ITEM	QTY	DESCRIPTION
1	1	SNAPNRACK END CLAMP UNIVERSAL WAVE, TYPE 2
2	1	SNAPNRACK END CLAMP UNIVERSAL WEDGE
3	1	5/16IN X 3/4IN SS FLAT WASHER
4	1	5-16IN-18 X 1-1-2IN SS HCS BOLT
5	1	SNAPNRACK UEC PULL STRAP

MATERIALS:	6000 SERIES ALUMINUM, STAINLESS STEEL
DESIGN LOAD (LBS):	800
ULTIMATE LOAD (LBS):	2400
TORQUE SPECIFICATION:	10+ FT-LBS
CERTIFICATION:	UL 2703, FILE E359313, DOMESTIC CONTENT COMPLIANT
WEIGHT (LBS):	0.24

DESCRIPTION:
SNAPNRACK, TDS, UNIVERSAL END CLAMP
 (USA)

DOC NUMBER:
 SNR-DC-01450

SnapNrack®

PART NUMBER(S):
 242-02215-USA

DRAWN BY:
 H.WULFEKOETTER

SNR SOLAR LLC
 775 FIERO LANE, SUITE 200
 SAN LUIS OBISPO, CA 93401 USA
 EMAIL: CONTACT@SNAPNRACK.COM

UNITS: IN, LB, DEG [MM, KG, DEG] SHEET: 2:2

REV: DATE:
A 11/21/2024

THE INFORMATION IN THIS DRAWING IS CONFIDENTIAL AND PROPRIETARY. ANY REPRODUCTION, DISCLOSURE, OR USE THEREOF IS PROHIBITED WITHOUT THE WRITTEN CONSENT OF SUNRUN SOUTH LLC.

