

DESCRIPTION:
**SNAPNRACK, TDS, ULTRAFOOT ANCHOR,
 BLACK (USA)**

DOC NUMBER:
 SNR-DC-01456

SnapNrack®

PART NUMBER(S):

242-10058-USA

DRAWN BY:
 H.WULFEKOETTER

REV: DATE:

A

11/22/2024

SNR SOLAR LLC

775 FIERO LANE, SUITE 200
 SAN LUIS OBISPO, CA 93401 USA
 EMAIL: CONTACT@SNAPNRACK.COM

THE INFORMATION IN THIS DRAWING IS CONFIDENTIAL AND PROPRIETARY. ANY
 REPRODUCTION, DISCLOSURE, OR USE THEREOF IS PROHIBITED WITHOUT THE
 WRITTEN CONSENT OF SNR SOLAR LLC.

UNITS: IN, LB, DEG [MM, KG, DEG]

SHEET: 1:2

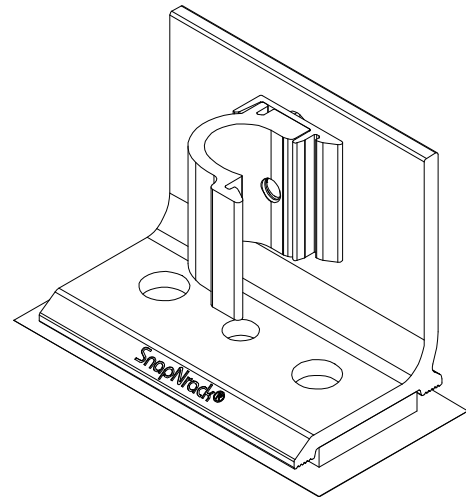
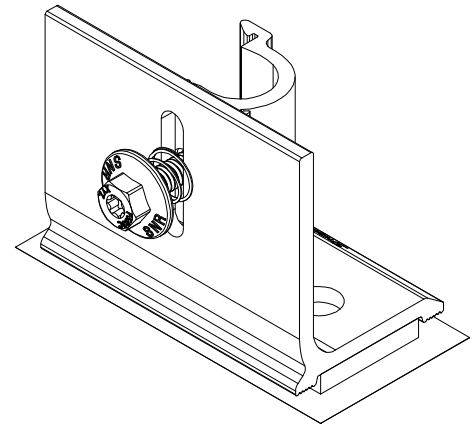
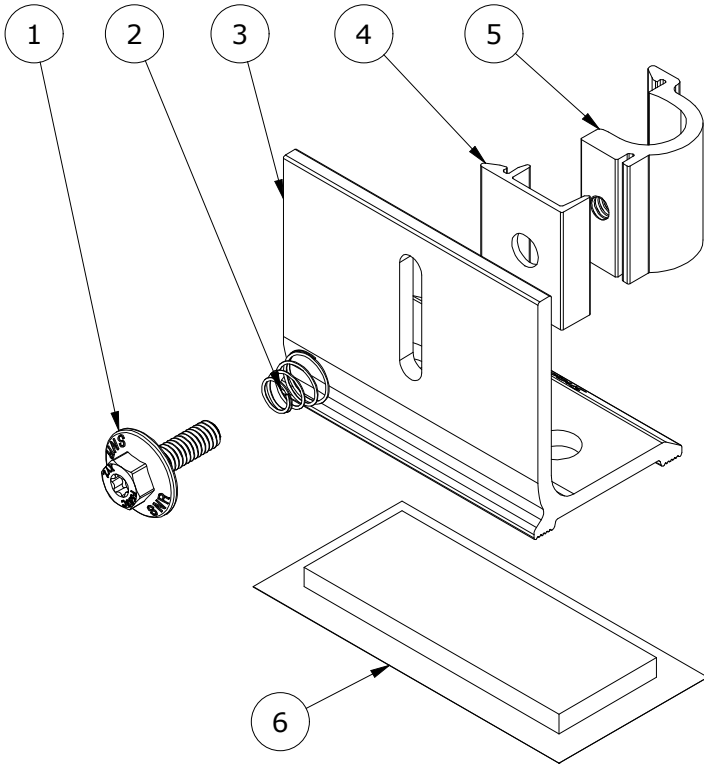

PARTS LIST

ITEM	QTY	DESCRIPTION
1	1	BOLT, WIDE FLANGE, RECESSED, 5-16IN-18 X 1IN, SS
2	1	SNAPNRACK, ULTRA RAIL MOUNT SPRING, SS
3	1	SNAPNRACK, ULTRAFOOT BASE, ANCHOR, BLACK
4	1	SNAPNRACK, UR FLIP CLAMP, THRU, SILVER
5	1	SNAPNRACK, FLIP CLAMP, TAP, BLACK
6	1	SNAPNRACK, BUTYL PAD, 2IN X 1.5IN X .25IN

MATERIALS:

6000 SERIES ALUMINUM & 300 SERIES STAINLESS STEEL

DESIGN LOAD (LBS):

VARIES, REFER TO SNAPNRACK ENGINEERING

ULTIMATE LOAD (LBS):

VARIES, REFER TO SNAPNRACK ENGINEERING

TORQUE SPECIFICATION:

16 FT-LBS FT-LBS

CERTIFICATION:

UL 2703, FILE E359313, DOMESTIC CONTENT COMPLIANT

WEIGHT (LBS):

0.550

DESCRIPTION:
**SNAPNRACK, TDS, ULTRAFOOT ANCHOR,
 BLACK (USA)**

DOC NUMBER:
 SNR-DC-01456

SnapNrack®

PART NUMBER(S):

242-10058-USA

DRAWN BY:
 H.WULFEKOETTER

REV: **A** DATE:
 11/22/2024

SNR SOLAR LLC

775 FIERO LANE, SUITE 200
 SAN LUIS OBISPO, CA 93401 USA
 EMAIL: CONTACT@SNAPNRACK.COM

THE INFORMATION IN THIS DRAWING IS CONFIDENTIAL AND PROPRIETARY. ANY REPRODUCTION, DISCLOSURE, OR USE THEREOF IS PROHIBITED WITHOUT THE WRITTEN CONSENT OF SNR SOLAR LLC.

UNITS: IN, LB, DEG [MM, KG, DEG]

SHEET: 2:2

