

DESCRIPTION:  
SNAPRACK, TDS, ULTRAFOOT DECK

DOC NUMBER:  
SNR-DC-01437

SnapNrack®

PART NUMBER(S):  
242-10057

DRAWN BY:  
M.AFFENTRANGER

REV: **B**      DATE:  
2/6/2025

SNR SOLAR LLC  
775 FIERO LANE, SUITE 200  
SAN LUIS OBISPO, CA 93401 USA  
EMAIL: CONTACT@SNAPNRACK.COM  
THE INFORMATION IN THIS DRAWING IS CONFIDENTIAL AND PROPRIETARY. ANY REPRODUCTION, DISCLOSURE, OR USE THEREOF IS PROHIBITED WITHOUT THE WRITTEN CONSENT OF SNR SOLAR LLC.

UNITS: IN, LB, DEG [MM, KG, DEG]      SHEET: 1:2

DESIGN REACTIONS, ALLOWABLE

FASTENER	SUBSTRATE	EMBEDMENT	UPLIFT (LB)	DOWNFORCE (LB)	SIDE (LB)	LATERAL (LB)
(2) #14 WOOD SCREW	WOOD FRAMING	1-1/4" EACH	1325	2500	702	853
(4) #14 WOOD SCREW	WOOD DECKING, 1/2" TRADE THICKNESS	FULL	285	350	180	245

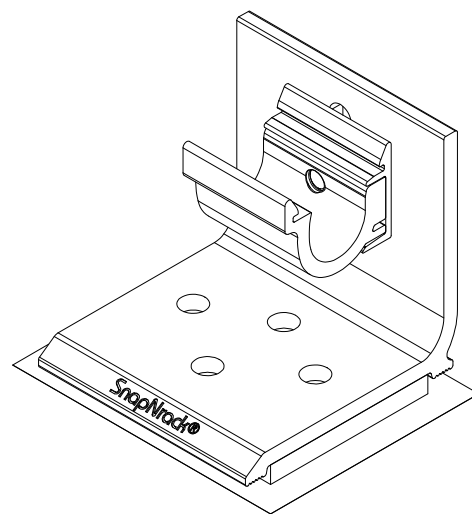
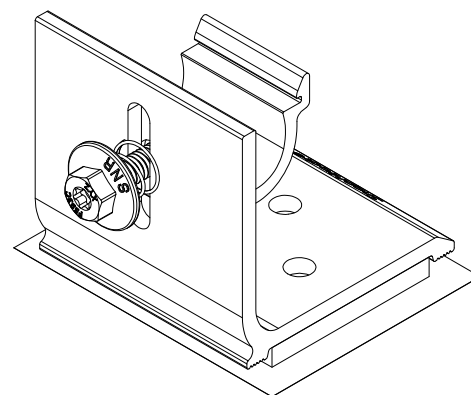
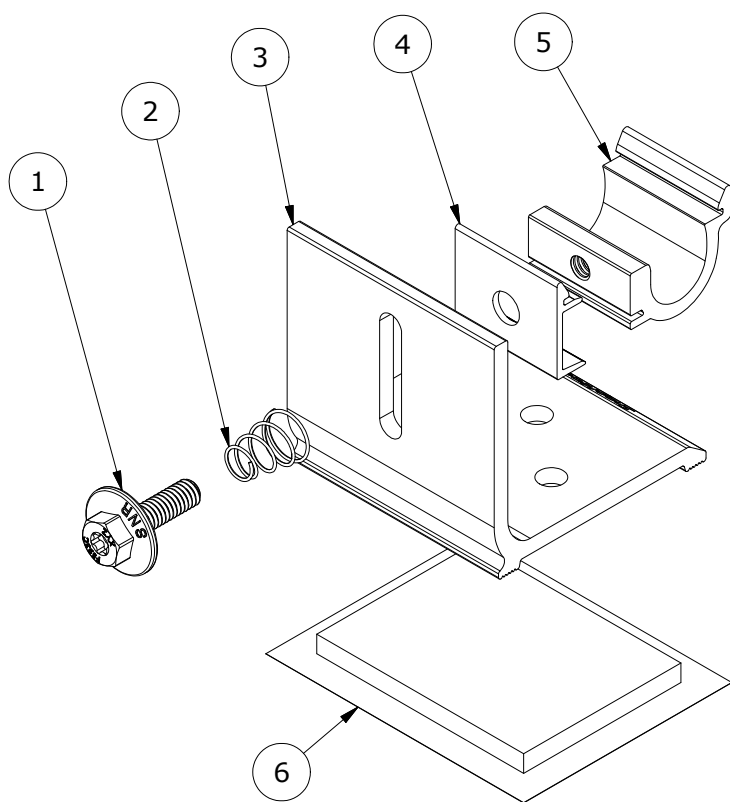

PARTS LIST

ITEM	QTY	DESCRIPTION
1	1	BOLT, WIDE FLANGE, RECESSED, 5-16IN-18 X 1IN, SS
2	1	SNAPRACK, ULTRA RAIL MOUNT SPRING, SS
3	1	SNAPRACK, ULTRAFOOT BASE, DECK, BLACK
4	1	SNAPRACK, UR FLIP CLAMP, THRU, SILVER
5	1	SNAPRACK, UR FLIP CLAMP, TAP, BLACK
6	1	SNAPRACK, BUTYL PAD, 2.00IN X 1.44IN X .25IN

MATERIALS: 6000 SERIES ALUMINUM & 300 SERIES STAINLESS STEEL

TORQUE SPECIFICATION: 16 FT-LBS FT-LBS

CERTIFICATION: UL 2703, FILE E359313

WEIGHT (LBS): 0.551

DESCRIPTION:  
**SNAPNRACK, TDS, ULTRAFOOT DECK**

DOC NUMBER:  
 SNR-DC-01437

**SnapNrack®**

PART NUMBER(S):  
**242-10057**

DRAWN BY:  
 M.AFFENTRANGER

SNR SOLAR LLC  
 775 FIERO LANE, SUITE 200  
 SAN LUIS OBISPO, CA 93401 USA  
 EMAIL: CONTACT@SNAPNRACK.COM  
THE INFORMATION IN THIS DRAWING IS CONFIDENTIAL AND PROPRIETARY. ANY REPRODUCTION, DISCLOSURE, OR USE THEREOF IS PROHIBITED WITHOUT THE WRITTEN CONSENT OF SNR SOLAR LLC.

UNITS: IN, LB, DEG [MM, KG, DEG]      SHEET: 2:2

REV:      DATE:  
**B**      2/6/2025

